

YAMAR

SERVICE MANUAL

L48N

L70N

L100N

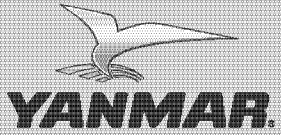

SERVICE MANUAL

INDUSTRIAL ENGINES

**L48N
L70N
L100N**

**California
Proposition 65 Warning**

Diesel engine exhaust and some of its constituents are known to the state of California to cause cancer, birth defects, and other reproductive harm.

**California
Proposition 65 Warning**

Battery posts, terminals, and related accessories contain lead and lead compounds, chemicals known to the state of California to cause cancer and reproductive harm.
Wash hands after handling.

LN series

SERVICE MANUAL

L48N
L70N
L100N

P/N: 0BLN0-G00100

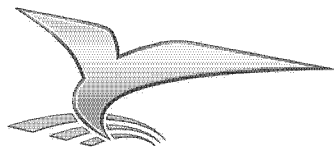

YANMAR
®

**INDUSTRIAL
ENGINES**

This *Service Manual* has been developed for the exclusive use of service and repair professionals such as Yanmar authorized Distributors and Yanmar authorized Dealers. It is written with these professionals in mind and may not contain the necessary detail or safety statements that may be required for a non-professional to perform the service or repair properly and / or safely. Please contact an authorized Yanmar repair or service professional before working on your Yanmar product.

Disclaimers:

All information, illustrations and specifications in this manual are based on the latest information available at the time of publishing. The illustrations used in this manual are intended as representative reference views only. Moreover, because of our continuous product improvement policy, we may modify information, illustrations, and / or specifications to explain and / or exemplify a product, service, or maintenance improvement. We reserve the right to make any change at any time.

Yanmar and **YANMAR** are registered trademarks of Yanmar Co., Ltd. in Japan, the United States and / or other countries.

All Rights Reserved:

No part of this publication may be reproduced or used in any form by any means - graphic, electronic or mechanical, including photocopying, recording, taping, or information storage and retrieval systems - without the written permission of Yanmar Co., Ltd.

© 2007 Yanmar Co. Ltd.

0207

TABLE OF CONTENTS

	Page
Table of Contents	iii
Introduction	1-1
Yanmar Warranties.....	2-1
Safety.....	3-1
General Service Information	4-1
Periodic Maintenance	5-1
Engine	6-1
Fuel System	7-1
Starter.....	8-1
Charging System.....	9-1
Electric Wiring	10-1
Troubleshooting	11-1

This Page Intentionally Left Blank

Section 1

INTRODUCTION

This manual describes the service procedures for the LN series air-cooled, vertical single-cylinder, 4-stroke, direct injection engines.

The use of this manual is recommended for safe, efficient and accurate servicing of the engine.

Use this manual together with the current model specific parts catalog for additional exploded part diagrams and identification of part numbers. Parts catalogs are intended for part number identification only. Exploded part diagrams within parts catalogs should not be used as an assembly reference. Follow the assembly procedures within the correct service manual for proper assembly instructions.

The information and procedures within this manual are for a typical engine. Some specifications and components may be different from your engine. All photographs and illustrations within this manual are intended as reference only and may not depict actual engine components or equipment.

When servicing optional engine equipment, refer to the documentation supplied by that optional equipment manufacturer for specific service instructions.

This manual may not include current field modifications or service updates that were not available at the time of printing. Contact an authorized Yanmar industrial engine dealer or distributor for current field modifications and service information.

This Page Intentionally Left Blank

Section 2

YANMAR WARRANTIES

	Page
Yanmar Limited Warranty.....	2-3
What is Covered by this Warranty?	2-3
How Long is the Warranty Period?	2-3
What the Engine Owner Must Do:	2-3
To Locate an Authorized Yanmar Industrial Engine Dealer or Distributor:	2-4
What Yanmar Will Do:	2-4
What is Not Covered by this Warranty?	2-4
Warranty Limitations:	2-5
Warranty Modifications:	2-5
Questions:	2-5
Retail Purchaser Registration.....	2-5
Warranty.....	2-6
Warranty Coverage:	2-6
Exclusions:	2-6
Owner's Warranty Responsibilities:.....	2-6

This Page Intentionally Left Blank

YANMAR LIMITED WARRANTY

What is Covered by this Warranty?

Yanmar warrants to the original retail purchaser that a new Yanmar LN Series Industrial Engine will be free from defects in material and / or workmanship for the duration of the warranty period.

Note: Yanmar engines may be equipped with external components including, but not limited to: wiring harnesses, electrical devices, control panels, radiators, air filters, fuel filters and / or exhaust systems that are supplied and / or installed by manufacturers other than Yanmar. For warranty information on such external components, please contact the machine or component manufacturer directly or see your authorized Yanmar dealer or distributor.

THIS WARRANTY IS PROVIDED IN LIEU OF ALL OTHER WARRANTIES, EXPRESS OR IMPLIED. YANMAR SPECIFICALLY DISCLAIMS ANY IMPLIED WARRANTIES OF MERCHANTABILITY OR FITNESS FOR A PARTICULAR PURPOSE, except where such disclaimer is prohibited by law. IF SUCH DISCLAIMER IS PROHIBITED BY LAW, THEN IMPLIED WARRANTIES SHALL BE LIMITED IN DURATION TO THE LIFE OF THE EXPRESS WARRANTY.

How Long is the Warranty Period?

The Yanmar standard limited warranty period runs for a period of **twenty-four (24) months or two-thousand (2000) engine operation hours**, whichever occurs first. The Warranty Period for the standard limited warranty (by duration or operation hours) begins on the date of delivery to the original retail purchaser and is valid only until the applicable warranted duration has passed or the operation hours are exceeded, whichever comes first.

What the Engine Owner Must Do:

If you believe your Yanmar engine has experienced a failure due to a defect in material and / or workmanship, you must contact an authorized Yanmar industrial engine dealer or distributor within thirty (30) days of discovering the failure. You must provide proof of ownership of the engine, proof of the date of the engine purchase and delivery, and documentation of the engine operation hours. Acceptable forms of proof of delivery date include, but are not limited to: the original warranty registration or sales receipts or other documents maintained in the ordinary course of business by Yanmar dealers and / or distributors, indicating the date of delivery of the Yanmar product to the original retail purchaser. This information is necessary to establish whether the Yanmar product is still within the warranty period. Thus, Yanmar strongly recommends you register your engine as soon as possible after purchase in order to facilitate any future warranty matters.

You are responsible for the transportation of the engine to and from the repair location as designated by Yanmar.

YANMAR WARRANTIES

Yanmar Limited Warranty - Continued

To Locate an Authorized Yanmar Industrial Engine Dealer or Distributor:

You can locate your nearest authorized Yanmar industrial engine dealer or distributor by visiting the Yanmar Corp., LTD. website at:

<http://www.yanmar.co.jp> (The Japanese language page will be displayed.) For the English language “click” on the language pull down menu and select “English”.

- “Click” on “Network” in the website heading to view the “Yanmar Worldwide Network.”
- Choose and “Click” on the desired product group.
- “Click” on the Icon closest to your region.
- “Click” on the desired country or Associate company to locate your nearest authorized Yanmar industrial engine dealer or distributor.
- You may also contact Yanmar by clicking on “Inquiry” in the website heading and typing in your question or comment.

What Yanmar Will Do:

Yanmar warrants to the original retail purchaser of a new Yanmar engine that Yanmar will make such repairs and / or replacements at Yanmar’s option, of any part(s) of the Yanmar product covered by this Warranty found to be defective in material and / or workmanship. Such repairs and / or replacements will be made at a location designated by Yanmar at no cost to the purchaser for parts or labor.

What is Not Covered by this Warranty?

This Warranty does not cover parts affected by or damaged by any reason other than defective materials or workmanship including, but not limited to, accident, misuse, abuse, “Acts of God,” neglect, improper installation, improper maintenance, improper storage, the use of unsuitable attachments or parts, the use of contaminated fuels, the use of fuels, oils, lubricants, or fluids other than those recommended in your Yanmar Service Manual, unauthorized alterations or modifications, ordinary wear and tear, and rust or corrosion. This Warranty does not cover the cost of parts and / or labor required to perform normal / scheduled maintenance on your Yanmar engine. This Warranty does not cover consumable parts such as, but not limited to, filters, belts, hoses, fuel injector nozzles, lubricants and cleaning fluids. This Warranty does not cover the cost of shipping the product to or from the Warranty repair facility.

Yanmar Limited Warranty - Continued

Warranty Limitations:

The foregoing is Yanmar's only obligation to you and your exclusive remedy for breach of warranty. Failure to follow the requirements for submitting a claim under this Warranty may result in a waiver of all claims for damages and other relief. **In no event shall Yanmar or any authorized industrial engine dealer or distributor be liable for incidental, special or consequential damages.** Such consequential damages may include, but not be limited to, loss of revenue, loan payments, cost of rental of substitute equipment, insurance coverage, storage, lodging, transportation, fuel, mileage and telephone costs. The limitations in this Warranty apply regardless of whether your claims are based on breach of contract, tort (including negligence and strict liability) or any other theory. Any action arising hereunder must be brought within one (1) year after the cause of action accrues or it shall be barred. Some states and countries do not allow certain limitations on warranties or for breach of warranties. **This Warranty gives you specific legal rights, and you may also have other rights which vary from state to state and country to country.** Limitations set forth in this paragraph shall not apply to the extent that they are prohibited by law.

Warranty Modifications:

Except as modified in writing and signed by the parties, this Warranty is and shall remain the complete and exclusive agreement between the parties with respect to warranties, superseding all prior agreements, written and oral, and all other communications between the parties relating to warranties. **No person or entity is authorized to give any other warranty or to assume any other obligation on behalf of Yanmar, either orally or in writing.**

Questions:

If you have any questions or concerns regarding this Warranty, please call or write to the nearest authorized Yanmar industrial engine dealer or distributor or other authorized facility.

Retail Purchaser Registration

It is very important for the original retail purchaser to register the Yanmar product. Registration enables Yanmar to provide the best support for your Yanmar product.

At the time of purchase, Yanmar highly recommends registering the retail purchaser's information through the website <http://www.yanmar.co.jp> as soon as possible.

If it is not possible to access the website, please contact the nearest authorized Yanmar industrial engine dealer or distributor.

WARRANTY

Warranty Coverage:

This warranty is transferable to each subsequent purchaser for the duration of the warranty period. Repair or replacement of any warranted part will be performed at an authorized Yanmar industrial engine dealer or distributor.

Warranted parts not scheduled for replacement as required maintenance in the Operation Manual shall be warranted for the warranty period. Warranted parts scheduled for replacement as required maintenance in the operation manual are warranted for the period of time prior to the first scheduled replacement. Any part repaired or replaced under warranty shall be warranted for the remaining warranty period.

During the warranty period, Yanmar is liable for damages to other engine components caused by the failure of any warranted part during the warranty period.

Any replacement part which is functionally identical to the original equipment part in all respects may be used in the maintenance or repair of your engine, and shall not reduce Yanmar's warranty obligations. Add-on or modified parts that are not exempted may not be used. The use of any non-exempted add-on or modified parts shall be grounds for disallowing a warranty.

Exclusions:

Failures other than those arising from defects in material and / or workmanship are not covered by this warranty. The warranty does not extend to the following: malfunctions caused by abuse, misuse, improper adjustment, modification, alteration, tampering, disconnection, improper or inadequate maintenance or use of non-recommended fuels and lubricating oils; accident-caused damage, and replacement of expendable items made in connection with scheduled maintenance. Yanmar disclaims any responsibility for incidental or consequential damages such as loss of time, inconvenience, loss of use of equipment / engine or commercial loss.

Owner's Warranty Responsibilities:

As the engine owner, you are responsible for the performance of the required maintenance listed in your owner's manual. Yanmar recommends that you retain all documentation, including receipts, covering maintenance on your non-road compression-ignition engine, but Yanmar cannot deny warranty solely for the lack of receipts, or for your failure to ensure the performance of all scheduled maintenance.

Yanmar may deny your warranty coverage of your non-road compression-ignition engine if a part has failed due to abuse, neglect, improper maintenance or unapproved modifications.

Your engine is designed to operate on diesel fuel only. Use of any other fuel may result in your engine no longer operating in compliance with applicable emissions requirements.

You are responsible for initiating the warranty process. You must present your engine to a Yanmar dealer as soon as a problem exists. The warranty repairs should be completed by the dealer as expeditiously as possible. If you have any questions regarding your warranty rights and responsibilities, or would like information on the nearest Yanmar dealer or authorized service center.

Section 3

SAFETY

	Page
Safety Statements	3-3
Before You Begin Servicing	3-4
Safety Precautions	3-4

This Page Intentionally Left Blank

SAFETY STATEMENTS

Yanmar is concerned for your safety and your machine's condition. Safety statements are one of the primary ways to call your attention to the potential hazards associated with Yanmar LN Series engine operation. Follow the precautions listed throughout the manual before operation, during operation and during periodic maintenance procedures for your safety, the safety of others and to protect the performance of your engine. Keep the labels from becoming dirty or torn and replace them if they are lost or damaged. Also, if you need to replace a part that has a label attached to it, make sure you order the new part and label at the same time.



This safety alert symbol appears with most safety statements. It means attention, become alert, your safety is involved! Please read and abide by the message that follows the safety alert symbol.

DANGER

Danger (the word "DANGER" is in white letters with a red rectangle behind it) - indicates an imminently hazardous situation which, if not avoided, will result in death or serious injury. Danger is limited to the most extreme situations.

0000001en

WARNING

Warning (the word "WARNING" is in black letters with an orange rectangle behind it) – indicates a potentially hazardous situation which, if not avoided, could result in death or serious injury.

0000001en

CAUTION

Caution (the word "CAUTION" is in black letters with a yellow rectangle behind it) – indicates a potentially hazardous situation which, if not avoided, may result in minor or moderate injury.

0000001en

CAUTION

Caution without the safety alert symbol indicates a potentially hazardous situation that can cause damage to the machine, personal property and / or the environment or cause the machine to operate improperly.

0000001en

BEFORE YOU BEGIN SERVICING

CAUTION

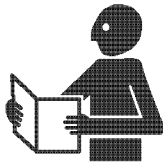

NEVER permit anyone to operate the engine or driven machine without proper training.

- Read and understand this Service Manual before you operate or service the machine to ensure that you follow safe operating practices and maintenance procedures.
- Machine safety signs and labels are additional reminders for safe operating and maintenance techniques.
- See your authorized Yanmar industrial engine dealer or distributor for additional training.

000002enSM

SAFETY PRECAUTIONS

DANGER



FIRE AND EXPLOSION HAZARD!

- Diesel fuel is flammable and explosive under certain conditions.
- **ALWAYS** put an approved container under any opening to catch the fuel when removing any fuel system component to perform maintenance (such as changing the fuel filter).
- **NEVER** use a shop rag to catch the fuel. Vapors from the rag are flammable and explosive.
- **ALWAYS** wipe up any spills immediately.
- **ALWAYS** wear eye protection. The fuel system is under pressure and fuel could spray out when you remove any fuel system component.
- Failure to comply will result in death or serious injury.

000009en

! DANGER**FIRE AND EXPLOSION HAZARD!**

- Only use the key switch to start the engine.
- NEVER jump-start the engine. Sparks caused by shorting the battery to the starter terminals may cause a fire or explosion.
- Failure to comply will result in death or serious injury.

000004en

! DANGER**FIRE AND EXPLOSION HAZARD!**

- Diesel fuel is flammable and explosive under certain conditions.
- ALWAYS fill the fuel tank only with specified diesel fuel. Filling the fuel tank with gasoline may result in a fire and will damage the engine.
- NEVER refuel with the engine running.
- ALWAYS wipe up all spills immediately.
- ALWAYS keep sparks, open flames or any other form of ignition (match, cigarette, static electric source) well away when refueling.
- NEVER overfill the fuel tank.
- Store any containers containing fuel in a well-ventilated area, away from any combustibles or sources of ignition.
- Failure to comply will result in death or serious injury.

000005en

DANGER



FIRE AND EXPLOSION HAZARD!

- Diesel fuel is flammable and explosive under certain conditions.
- Be sure to place the diesel fuel container on the ground when transferring the diesel fuel from the pump to the container. Hold the hose nozzle firmly against the side of the container while filling. This prevents static electricity buildup which could cause sparks and ignite fuel vapors.
- NEVER place diesel fuel or other flammable material such as oil, hay or dried grass close to the engine during engine operation or shortly after shut down.
- Never inject fuel toward a fire source. Atomized fuel is highly flammable and may cause a fire or burn skin.
- Failure to comply will result in death or serious injury.

0000014enT80

DANGER



CRUSH HAZARD!

- When you need to transport an engine for repair, have a helper assist you to attach it to a hoist and load it on a truck.
- NEVER stand under a hoisted engine. If the hoist mechanism fails, the engine will fall on you, causing death or serious injury.
- Failure to comply will result in death or serious injury.

0000008en

DANGER



FIRE AND EXPLOSION HAZARD!

- Diesel fuel is flammable and explosive under certain conditions.
- ALWAYS check for fuel leaks before you operate the engine. Replace rubberized fuel hoses every two years or every 2000 hours of engine operation, whichever comes first, even if the engine has been out of service. Rubberized fuel lines tend to dry out and become brittle after two years or 2000 hours of engine operation, whichever comes first.
- Failure to comply will result in death or serious injury.

0000015en

! DANGER**EXPLOSION HAZARD!**

- NEVER check the remaining battery charge by shorting out the terminals. This will result in a spark and may cause an explosion or fire. Use a hydrometer to check the remaining battery charge.
- If the electrolyte is frozen, slowly warm the battery before you recharge it.
- Failure to comply will result in death or serious injury.

000007en

! DANGER**FIRE AND EXPLOSION HAZARD!**

- Diesel fuel is extremely flammable and explosive under certain conditions.
- The procedures used to prime gravity-fed fuel systems and fuel systems pressurized by an electric pump are different. See *Section 4 - Priming The Fuel System*.
- Place an approved container under the high-pressure line fitting when you prime the fuel system. Never use a shop rag to catch the fuel. Wipe up any spills immediately.
- Wear eye protection. The fuel system is under pressure and fuel could spray out when you open the high-pressure line fitting.
- Failure to comply will result in death or serious injury.

000006enlva

! DANGER**FIRE AND EXPLOSION HAZARD!**

- Diesel fuel is flammable and explosive under certain conditions.
- NEVER remove the fuel cap with the engine running.
- Failure to comply will result in death or serious injury.

0000011en

WARNING



SEVER HAZARD!

- Keep hands and other body parts away from moving / rotating parts such as the cooling fan / flywheel.
- Wear tight-fitting clothing and keep your hair short or tie it back while the engine is running.
- Remove all jewelry before you operate or service the machine.
- NEVER start the engine in gear. Sudden movement of the engine and / or machine could cause death or serious personal injury.
- NEVER operate the engine without the guards in place.
- Before you start the engine make sure that all bystanders are clear of the area.
- Keep children and pets away while the engine is operating.
- Check before starting the engine that any tools or shop rags used during maintenance have been removed from the area.
- Failure to comply could result in death or serious injury.

000002enLV

WARNING



EXHAUST HAZARD!

- NEVER operate the engine in an enclosed area such as a garage, tunnel, underground room, manhole or ship's hold without proper ventilation.
- NEVER block windows, vents, or other means of ventilation if the engine is operating in an enclosed area. All internal combustion engines create carbon monoxide gas during operation. Accumulation of this gas within an enclosure could cause illness or even death.
- Make sure that all connections are tightened to specifications after repair is made to the exhaust system.
- Failure to comply could result in death or serious injury.

000003en

WARNING



ALCOHOL AND DRUG HAZARD!

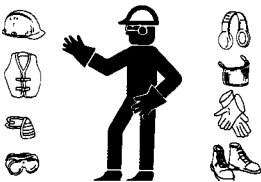

- NEVER operate the engine while you are under the influence of alcohol or drugs.
- NEVER operate the engine when you are feeling ill.
- Failure to comply could result in death or serious injury.

000004en

 WARNING

<p style="text-align: center;">EXPOSURE HAZARD!</p> <ul style="list-style-type: none"> • ALWAYS wear personal protective equipment such as gloves, work shoes, eye and hearing protection as required by the task at hand. • NEVER wear jewelry, unbuttoned cuffs, ties or loose-fitting clothing when you are working near moving / rotating parts such as the cooling fan, flywheel or PTO shaft. • ALWAYS tie back long hair when you are working near moving / rotating parts such as a cooling fan, flywheel, or PTO shaft. • NEVER operate the engine while wearing a headset to listen to music or radio because it will be difficult to hear the alert signals. • Failure to comply could result in death or serious injury. <p style="text-align: right;">0000005en</p>

 WARNING

<p style="text-align: center;">BURN HAZARD!</p> <ul style="list-style-type: none"> • ALWAYS stay clear of the hot engine oil to avoid being burned. • ALWAYS wear eye protection. • Failure to comply could result in serious injury. <p style="text-align: right;">0000011en</p>

 WARNING

<p style="text-align: center;">BURN HAZARD!</p> <ul style="list-style-type: none"> • Batteries contain sulfuric acid. NEVER allow battery fluid to come in contact with clothing, skin or eyes. Severe burns could result. ALWAYS wear safety goggles and protective clothing when servicing the battery. If battery fluid contacts the eyes and / or skin, immediately flush the affected area with a large amount of clean water and obtain prompt medical treatment. • Failure to comply could result in death or serious injury. <p style="text-align: right;">0000007en</p>

⚠ WARNING



HIGH-PRESSURE HAZARD!

- Avoid skin contact with the high-pressure diesel fuel spray caused by a fuel system leak such as a broken fuel injection line. High-pressure fuel can penetrate your skin and result in serious injury. If you are exposed to high-pressure fuel spray, obtain prompt medical treatment.
- NEVER check for a fuel leak with your hands. ALWAYS use a piece of wood or cardboard. Have your authorized Yanmar industrial engine dealer or distributor repair the damage.
- Failure to comply could result in death or serious injury.

000008en

⚠ WARNING



SHOCK HAZARD!

- ALWAYS turn off the battery switch (if equipped) or disconnect the negative battery cable before servicing the electrical system.
- Check the electrical harnesses for cracks, abrasions, and damaged or corroded connectors. ALWAYS keep the connectors and terminals clean.
- Failure to comply could result in death or serious injury.

000009en

⚠ WARNING



ENTANGLEMENT HAZARD!

- ALWAYS stop the engine before you begin to service it.
- NEVER leave the key in the key switch when you are servicing the engine. Someone may accidentally start the engine and not realize you are servicing it.
- Failure to comply could result in death or serious injury.

000010en

⚠ WARNING

SUDDEN MOVEMENT HAZARD!

- ALWAYS allow the engine to warm-up for at least 5 minutes to allow the engine idle speed to return to normal before engaging the transmission or any PTO attachments.
- NEVER engage the transmission or PTO at an elevated engine speed.
- Failure to comply could result in death or serious injury.

000006en

⚠ WARNING**BURN HAZARD!**

- NEVER touch hot engine surfaces such as the muffler, exhaust pipe, turbocharger (if equipped) and engine block during operation and shortly after you shut the engine down. These surfaces are extremely hot while the engine is operating and could seriously burn you.
- Failure to comply could result in death or serious injury.

0000015en

⚠ WARNING

ALWAYS wear **SAFETY GLASSES** while servicing the engine to prevent possible eye injury.

0000013en

⚠ WARNING**FUME / BURN HAZARD!**

- ALWAYS read and follow safety related precautions found on containers of hazardous substances like parts cleaners, primers, sealants and sealant removers.
- Failure to comply could result in death or serious injury.

0000014en

⚠ WARNING**BURN HAZARD!**

- Handle hot components with heat-resistant gloves.
- Failure to comply could result in death or serious injury.

0000110en

⚠ CAUTION



FLYING OBJECT HAZARD!

- **ALWAYS** wear eye protection when servicing the engine and when using compressed air or high-pressure water. Dust, flying debris, compressed air, pressurized water or steam may injure your eyes.
- Failure to comply may result in minor or moderate injury.

000003en

⚠ CAUTION

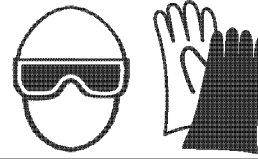

FLYING OBJECT HAZARD!

The starter spring is under considerable tension when installing or removing it from the recoil housing and can unexpectedly come out of the housing.

- **ALWAYS** wear gloves and safety glasses when repairing the recoil starter.
- Failure to comply may result in minor or moderate injury.

0000030en

⚠ CAUTION

Be sure to secure the engine solidly to prevent injury or damage to parts due to the engine falling during work on the engine.

000009en

CAUTION

NEVER hold the key in the START position for longer than 15 seconds or the starter motor will overheat.

000007en

CAUTION

- Only use diesel fuels recommended by Yanmar for the best engine performance, to prevent engine damage.
- Only use clean diesel fuel.
- **NEVER** remove inlet fuel screen from the filler port. If removed, dirt and debris could get into the fuel system causing blockage or damage to the fuel system components.

000004enLN

CAUTION

- NEVER remove or attempt to remove the tamper-proof devices from the high-speed throttle limit screw. This adjustment has been made at the factory to meet all applicable emissions regulations and then sealed.
- DO NOT attempt to remove or adjust the fuel limiter assembly.
- NEVER attempt to make adjustments to any sealed adjustment screw.
- Any alterations to this engine may affect the warranty coverage of this engine.
- See *Yanmar Limited Warranty in Section 2.*

0000174en

CAUTION

Make sure the engine is installed on a level surface. If a continuously running engine is installed at an angle greater than 20° (in any direction) or if an engine runs for short periods of time (less than three minutes) at an angle greater than 25° in any direction, engine oil may enter the combustion chamber causing excessive engine speed and generate white smoke. This may cause serious engine damage.

0000010enTNE

CAUTION

For maximum engine life, Yanmar recommends that when shutting the engine down, allow the engine to idle, without load, for five minutes. This will allow the engine components that operate at high temperatures, such as the turbocharger (if equipped) and exhaust system, to cool slightly before the engine itself is shut down.

0000008en

CAUTION

Observe the following environmental operating conditions to maintain engine performance and avoid premature engine wear:

- Avoid operating in extremely dusty conditions.
- Avoid operating in the presence of chemical gases or fumes.
- Avoid operating in a corrosive atmosphere such as salt water spray.
- NEVER install the engine in a floodplain unless proper precautions are taken to avoid being subject to a flood.
- NEVER expose the engine to the rain.

0000003en

CAUTION

- NEVER overfill the engine with engine oil.
- ALWAYS keep the oil level between the upper and lower lines on the oil cap / dipstick.

0000015en

CAUTION

Observe the following environmental operating conditions to maintain engine performance and avoid premature engine wear:

- The standard range of ambient temperatures for the normal operation of Yanmar engines is from +5°F (-15°C) to +113°F (+45°C).
- If the ambient temperature exceeds +113°F (+45°C) the engine may overheat and cause the engine oil to break down.
- If the ambient temperature is below +5°F (-15°C) the engine will be hard to start and the engine oil may not flow easily.
- Contact your authorized Yanmar industrial engine dealer or distributor if the engine will be operated outside of this standard temperature range.

0000065en

CAUTION

The starter motor can be damaged if operated continuously longer than 10 seconds while performing the no-load test.

0000034en

CAUTION

- **ALWAYS** use only the engine oil specified. Other engine oils may affect warranty coverage, cause internal engine components to seize and / or shorten engine life.
- **ALWAYS** prevent dirt and debris from contaminating the engine oil. Carefully clean the oil cap / dipstick and the surrounding area before you remove the cap.
- **NEVER** mix different types of engine oil. This may adversely affect the lubricating properties of the engine oil.
- **NEVER** overfill. Overfilling may result in white exhaust smoke, engine overspeed or internal damage.

0000005en

CAUTION

NEVER use an engine starting aid such as ether. Engine damage will result.

0000009en

CAUTION

- **ALWAYS** be environmentally responsible.
- Follow the guidelines of the governmental agencies for the proper disposal of hazardous materials such as engine oil, diesel fuel and engine coolant. Consult the local authorities or reclamation facility.
- **NEVER** dispose of hazardous materials irresponsibly by dumping them into a sewer, on the ground, or into ground water or waterways.
- Failure to follow these procedures may seriously harm the environment.

0000013enLN

CAUTION

NEVER engage the starter motor while the engine is running. This may damage the starter motor pinion and / or ring gear.

0000012en

CAUTION

- **NEVER** attempt to modify the engine's design or safety features such as defeating the engine speed limit control or the fuel injection quantity control.
- Failure to comply may impair the engine's safety and performance characteristics and shorten the engine's life. Any alterations to this engine may affect the warranty coverage of your engine. *See Yanmar Limited Warranty in Warranty Section.*

0000044enTNVDISM

CAUTION

ALWAYS protect the air cleaner, turbocharger (if equipped) and electric components from damage when you use steam or high-pressure water to clean the engine.

0000014en

CAUTION

Establish a periodic maintenance plan according to the engine application and make sure you perform the required periodic maintenance at intervals indicated. Failure to follow these guidelines will impair the engine's safety and performance characteristics, shorten the engine's life and may affect the warranty coverage on your engine.

See Yanmar Limited Warranty on page 2-3.

Consult your authorized Yanmar industrial engine dealer or distributor for assistance when checking items marked with a ●.

0000024enLVOM

CAUTION

Establish a periodic maintenance plan according to the engine application and make sure you perform the required periodic maintenance at the intervals indicated. Failure to follow these guidelines will impair the engine's safety and performance characteristics, shorten the engine's life and may affect the warranty coverage on your engine.

See Yanmar Limited Warranty in Warranty Section.

Consult your authorized Yanmar dealer or distributor for assistance when checking items marked with a ●.

0000024enTNVDISM

CAUTION

- When the engine is operated in dusty conditions, clean the air cleaner element more frequently.
- NEVER operate the engine with the air cleaner element(s) removed. This may allow foreign material to enter the engine and damage it.

0000026en

CAUTION

It is important to perform daily checks.

Periodic maintenance prevents unexpected downtime, reduces the number of accidents due to poor machine performance and helps extend the life of the engine.

0000060en

CAUTION

The starter motor can be damaged if operated continuously longer than 10 seconds while performing the no-load test.

0000034en

CAUTION

Do not turn the battery switch OFF while the engine is operating. Damage to the alternator will result.

0000038en

CAUTION

Do not reverse the positive (+) and negative (-) ends of the battery cable. The alternator diode and stator coil will be damaged.

0000050en

CAUTION

When the battery indicator goes out, it should not come on again. The battery indicator only comes on during operation if the alternator fails. However, if an LED is used in the battery indicator, the LED will shine faintly during normal operation.

0000051en

CAUTION

Agricultural or other chemicals, especially those with a high sulfur content, can adhere to the IC regulator. This will corrode the conductor and result in battery over-charging (boiling) and charging malfunctions. Consult Yanmar before using the equipment in such an environment or the warranty is voided.

0000053en

CAUTION

Removing the battery cables or the battery while the engine is operating may cause damage to the current limiter depending on the electrical equipment being used. This situation could cause loss of control of output voltage. The continuous high voltage of 23-24 volts (for 5000 rpm dynamo) will damage the current limiter and other electrical equipment.

0000058en

CAUTION

The starter motor is water-proofed according to JIS D 0203, R2 which protects the motor from rain or general cleaning. Do not use high-pressure wash or submerge the starter motor in water.

0000055en

CAUTION

Reversing the battery cable connections at the battery or on the engine will destroy the SCR diode in the current limiter. This will cause the charging system to malfunction and may cause damage to the electrical harnesses.

0000059en

CAUTION

Make sure that the combined total resistance of the battery cable in both directions between the starter motor and the battery is within the value indicated in the *Battery Cable Resistance chart* in the *Electric Wiring Section* of this manual. The starter motor will malfunction and fail if the resistance is higher than the specified value.

0000057en

CAUTION

Do not allow the honing tool to operate in one position for any length of time. Damage to the cylinder wall will occur. Keep the tool in constant up-and-down motion.

0000090en

CAUTION

Any part which is found defective as a result of inspection or any part whose measured value does not satisfy the standard or limit must be replaced.

0000119en

CAUTION

- **NEVER** remove or attempt to remove the tamper-proof devices from the high-speed throttle limit screw. This adjustment has been made at the factory to meet all applicable emissions regulations and then sealed.
- **DO NOT** attempt to remove or adjust the fuel limiter assembly.
- **NEVER** attempt to make adjustments to any sealed adjustment screw.
- Any alterations to this engine may affect the warranty coverage of this engine.
- *See Yanmar Limited Warranty in Section 2.*

0000174en

CAUTION

Never use a steel wire brush to clean fuel injectors. Damage to the nozzle and other components is likely to result.

0000172en

CAUTION

Use a specialized battery charger to recharge a battery with a voltage of 8 volts or less. Booster starting a battery with a voltage of 8 volts or less will generate an abnormally high voltage and destroy electrical equipment.

0000056en

CAUTION

NEVER allow the recoil handle to snap back against the engine. Return the handle to the starting position gently to prevent damage to the starter.

0000066en

Section 4

GENERAL SERVICE INFORMATION

	Page
Component Identification.....	4-3
Location of Labels	4-4
Specifications	4-5
Description of Model Number	4-5
Engine Speed Specifications.....	4-5
General Engine Specifications	4-6
Function of Major Engine Components	4-8
Diesel Fuel	4-9
Diesel Fuel Specifications	4-9
Filling the Fuel Tank	4-10
Priming the Fuel System	4-12
Engine Oil.....	4-14
Engine Oil Specifications.....	4-14
Engine Oil Viscosity.....	4-14
Engine Oil Capacity (Typical)	4-15
Checking Engine Oil.....	4-15
Adding Engine Oil.....	4-15
Abbreviations and Symbols.....	4-16
Abbreviations.....	4-16
Symbols.....	4-16
Unit Conversions	4-17
Unit Prefixes	4-17
Units of Length	4-17
Units of Volume	4-17
Units of Mass.....	4-17
Units of Force	4-17

GENERAL SERVICE INFORMATION

Units of Torque.....	4-17
Units of Pressure.....	4-17
Units of Power.....	4-17
Units of Temperature.....	4-17
Tightening Torques for Standard Bolts and Nuts.....	4-18
Tightening Torques for Special Bolts and Nuts.....	4-20

COMPONENT IDENTIFICATION

Figure 4-1 shows where major engine components are located.

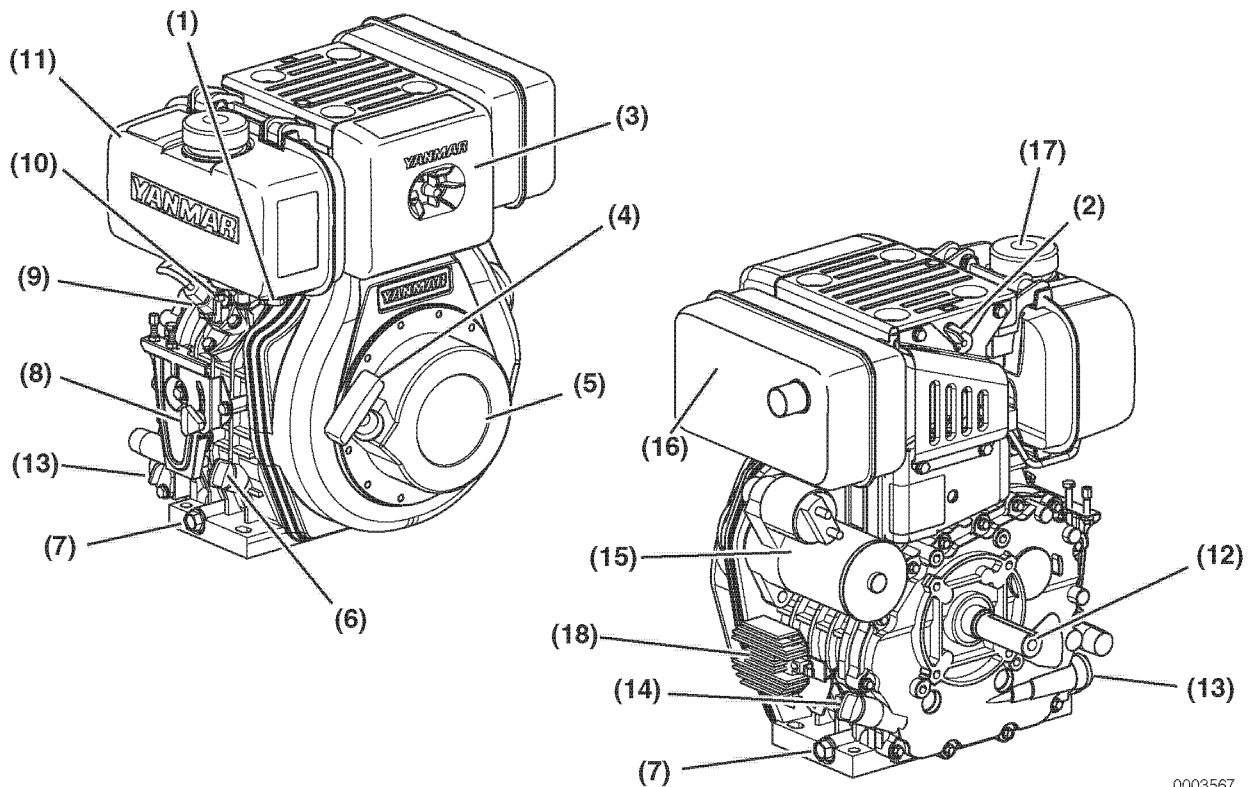

0003567

Figure 4-1

- | | |
|------------------------------|--------------------------|
| 1 – Fuel Tank Drain Plug | 10 – Fuel Shut-Off Valve |
| 2 – Compression Relief Lever | 11 – Fuel Tank |
| 3 – Air Cleaner | 12 – PTO Shaft |
| 4 – Recoil Starter Handle | 13 – Oil Filter |
| 5 – Recoil Starter | 14 – Oil Cap / Dipstick |
| 6 – Oil Cap / Dipstick | 15 – Electric Starter |
| 7 – Oil Drain Plug | 16 – Muffler |
| 8 – Engine Speed Control | 17 – Fuel Tank Cap |
| 9 – Fuel Injection Pump | 18 – Regulator/Rectifier |

Note: L48N “standard” engines are not equipped with top engine covers. The illustrations in this manual show “typical” L70N and L100N engines and may show engines with “optional” and/or “non-standard” equipment.

LOCATION OF LABELS

Figure 4-2 shows the location of regulatory and safety labels on Yanmar LN Series engines.

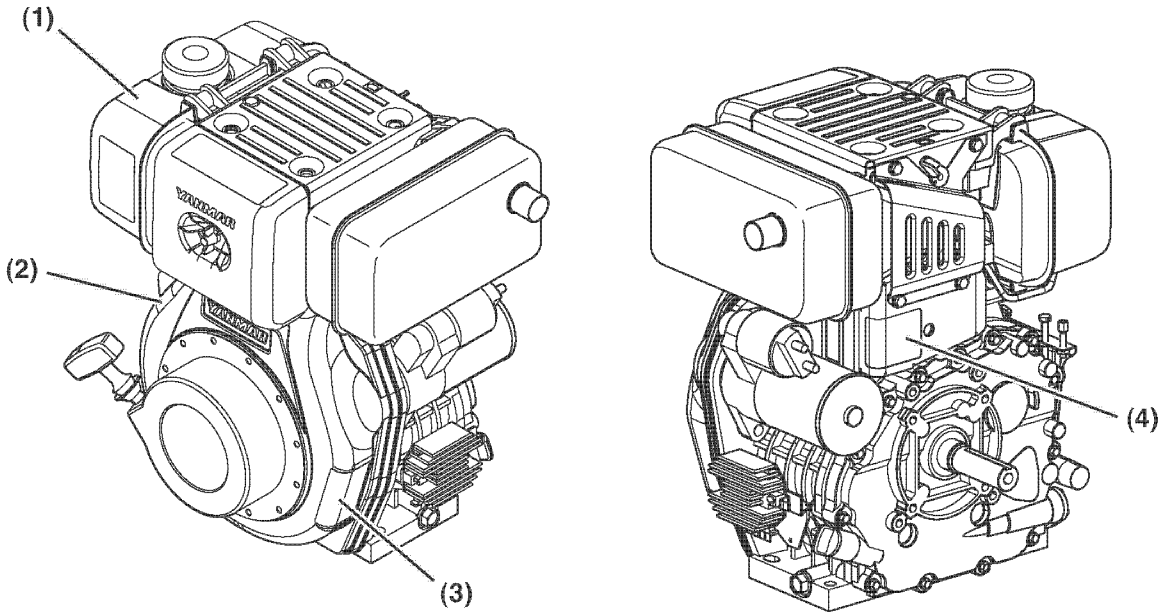

Figure 4-2

The typical location of the emission control information label for LN Series engines is on the top of the fuel tank (Figure 4-2, (1)).

- On L48N engines not equipped with a Yanmar fuel tank, the label is located on the flywheel cover (Figure 4-2, (2)).
- On L70N and L100N engines not equipped with a Yanmar fuel tank, the label is on the flywheel cover (Figure 4-2, (3)).

Typical location of the engine nameplate is on the engine side cover as shown in Figure 4-2 (4).

Engine Nameplate (Typical)

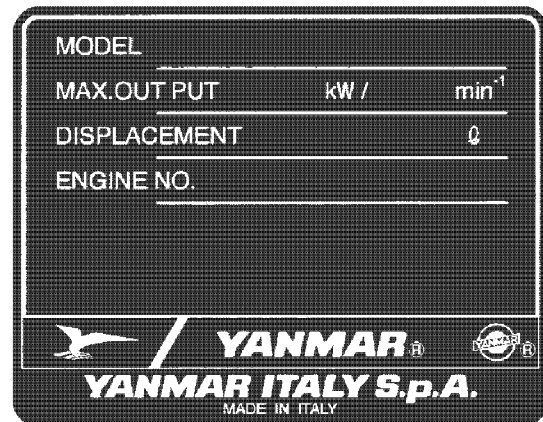

0004192

SPECIFICATIONS

Description of Model Number

	1	2	3	4	5	6	7	8	9	10	11
L 4 8											
L 7 0	N	6	A	F	1	T	1	A	A	S	1
L 1 0 0											

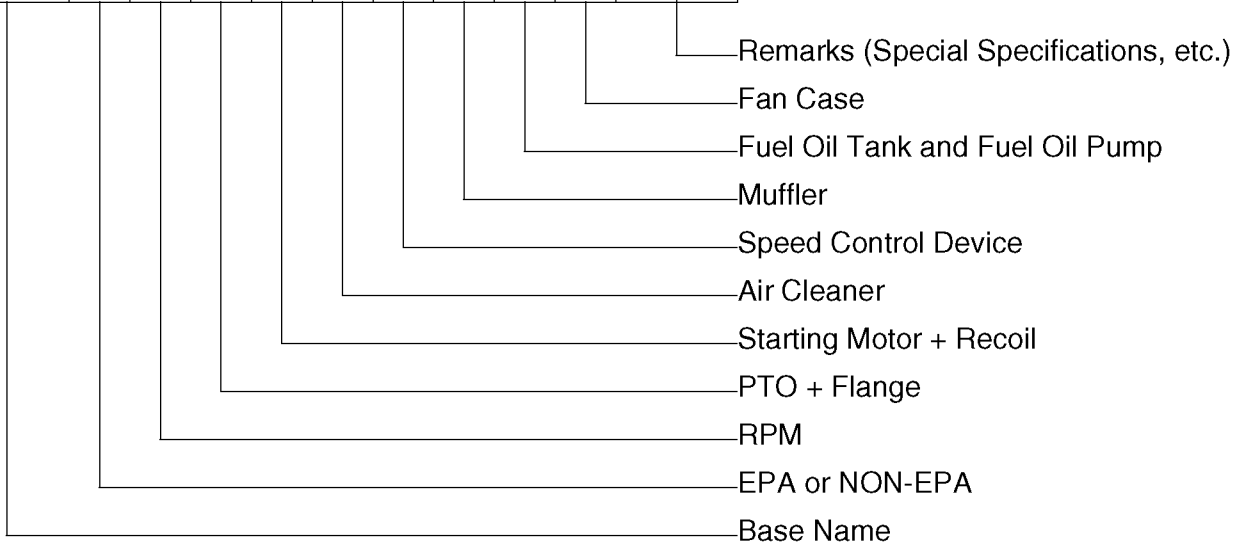

Engine Speed Specifications

Available Engine Speed	Intended Uses
2500 - 3450 rpm (min ⁻¹)	Agricultural, Construction, Industrial Machines
3600 rpm (min ⁻¹)	Generator Sets, Pumps

GENERAL SERVICE INFORMATION

General Engine Specifications

Engine Model		L48N	L70N	L100N	
Type		4-stroke, Vertical Cylinder, Air-Cooled Diesel Engine			
Combustion System		Direct Injection			
No. of Cylinders		1			
Bore x Stroke		2.76 x 2.24 in. (70 x 57 mm)	3.07 x 2.64 in. (78 x 67 mm)	3.39 x 2.95 in. (86 x 75 mm)	
Displacement		13.4 cu in (0.219 L)	19.5 cu in. (0.320 L)	26.5 cu in. (0.435 L)	
Compression Ratio		20.1 ± 0.5	20.0 ± 0.3	20.0 ± 0.3	
Continuous Rated Output	RPM (min ⁻¹)	3600	3600	3600	
	hp SAE	4.1	5.9	8.3	
	kW	3.1	4.4	6.2	
	PS	4.2	6.0	8.4	
Maximum Rated Output (Net)	RPM (min ⁻¹)	3600	3600	3600	
	hp SAE	4.6	6.6	9.1	
	kW	3.5	4.9	6.8	
	PS	4.7	6.7	9.3	
High Idling	RPM (min ⁻¹)	3800 ± 30	3800 ± 30	3800 ± 30	
Low Idling	RPM (min ⁻¹)	1250 ± 30 (Where applicable, as some engines and generators do not operate at idle and/or have no idle speed adjustment)			
Fuel Injection Timing	BTDC by FIC (A)	16.5°	13.0°	13.0°	16.5° 13.5°
Valve Clearance		0.006 ± 0.002 in. (0.15 ± 0.05 mm)			
PTO Position		Crankshaft			
Direction of Rotation		Counterclockwise viewed from PTO Side			
Fuel Injection Pump		BOSCH-type, with upper lead plunger			
Fuel Injection Nozzle		P-size, VCO			
Valve Opening Pressure		19.6 MPa (200 kgf/cm ²)			
Fuel Selection		<i>See Diesel Fuel on page 4-9.</i>			
Fuel Filter		Paper Element, Fuel Tank Built-in Type			
Governor		All Speed Type, Mechanical			
Balancer Shaft		Single Shaft			
Engine Weight (Dry)	Electric Start	70.5 lb (32.0 kg)	90.4 lb (41.0 kg)	118 lb (53.5 kg)	
	Manual Start	59.5 lb (27.0 kg)	79.4 lb (36.0 kg)	107 lb (48.5 kg)	
Cooling System		Forced Air by Flywheel Fan			
Lubricating System		Forced Lubrication with Trochoid Pump Splash Lubrication for Valve Rocker Arm Chamber			

GENERAL SERVICE INFORMATION

Engine Model		L48N		L70N		L100N		
Oil Selection		<i>See Engine Oil on page 4-14.</i>						
Oil Filter		Resin, 60 Mesh						
Permissible Angle of Inclination		20° (momentary 30°)						
Air Cleaner		Wet-Type Paper Element Filter			Dry-Type Paper Element Filter			
Muffler		Expansion Silencer with Cover						
Starting System		Electric Start / Recoil Start						
Dimensions (L x W x H)		13.1 x 15.1 x 16.4 in. (332 x 384 x 417 mm)			14.9 x 16.6 x 17.8 in. (378 x 422 x 453 mm)		16.2 x 18.5 x 19.4 in. (412 x 471 x 494 mm)	
Engine Oil Pan Capacity	Dipstick Upper Limit	0.85 qt (0.8 L) 0.58 qt (0.55 L)			1.11 qt (1.05 L)		1.7 qt (1.6 L)	
	Dipstick Lower Limit				0.69 qt (0.65 L)		1.06 qt (1.0 L)	
Fuel Tank Capacity ("Standard" Fuel Tank)		2.0 qt (1.9 L)			2.85 qt (2.7 L)		5.0 qt (4.7 L)	
Battery Capacity								
Ambient Tempera- ture usage by model	L48N	-10°C (14°F) or higher		-30°C (-22°F) or higher				
	L70N		-10°C (14°F) or higher		-30°C (-22°F) or higher			
	L100N				-10°C (14°F) or higher		-30°C (-22°F) or higher	
Battery Capacity (Recommended)		100 CCA	135 CCA	170 CCA	200 CCA	225 CCA	250 CCA	
		18 Ah	24 Ah	30 Ah	35 Ah	40 Ah	45 Ah	

Notes:

1. The information described in *General Engine Specifications on page 4-6* is for a "standard" engine. To obtain the information for the engine installed in your driven machine, please refer to the manual provided by the driven machine manufacturer.
2. Engine rating conditions are as follows (SAE J1349, ISO 3046/1):
 - Atmospheric Condition: Room temperature 77°F (25°C), Atmospheric pressure 29.53 in.Hg (100 kPa, 750 mm Hg), Relative humidity 30%
 - Fuel Temperature at Fuel Injector Pump Inlet: 104°F (40°C)
 - With Cooling Fan, Air Cleaner, Muffler: Yanmar Standard
 - After Engine Break-In Period. Output Allowable Deviation: ± 3%
 - 1 PS = 0.7355 kW
 - 1 hp SAE (Society of Automotive Engineers) = 0.7457 kW

GENERAL SERVICE INFORMATION

FUNCTION OF MAJOR ENGINE COMPONENTS

Components	Functions
Air Cleaner	The air cleaner prevents airborne contaminants from entering the engine. Periodic replacement of the air cleaner filter element is necessary. See <i>Periodic Maintenance Schedule on page 5-15</i> for the replacement frequency.
Dynamo (Optional)	If the engine is equipped with the electric starting option, a charging dynamo is located under the engine flywheel. The dynamo supplies electricity to the engine systems and charges the battery while the engine is running.
Electric Fuel Pump (Optional)	If equipped with the standard Yanmar fuel tank, the fuel tank is installed above the level of the fuel injection pump and fuel is gravity-fed to the injection pump. If an optional or alternate fuel tank is installed below the level of the fuel injection pump, an electric fuel supply pump is required to ensure a constant supply of fuel to the fuel injection pump.
Engine Oil Filter	The engine oil filter removes contaminants and sediment from the engine oil. Periodic cleaning of the oil filter is necessary. See <i>Periodic Maintenance Schedule on page 5-15</i> for the frequency of cleaning.
Fuel Filters	Two fuel filters are provided to remove contaminants and sediments from the diesel fuel. The inlet fuel screen is located inside the fuel tank filler port. Since it uses a mesh construction, it can be cleaned. The outlet fuel filter is a replaceable cartridge that is located at the outlet of the fuel tank. Periodic cleaning / replacement is required. See <i>Periodic Maintenance Schedule on page 5-15</i> .
Fuel Tank	The fuel tank is a reservoir that holds diesel fuel. When fuel leaves the fuel tank it goes to the fuel injection pump. Since fuel is used to keep fuel system components cool and lubricated, more fuel than is necessary for combustion enters the fuel system. Any fuel that is not used for combustion is returned to the fuel tank.
Oil Cap / Dipstick (Engine Oil)	The engine oil cap / dipstick combines the oil cap and dipstick in one assembly. The dipstick part of the assembly is used to determine the amount of engine oil in the crankcase.
Side Filler Ports (Engine Oil)	You can fill the crankcase with engine oil from <i>either side</i> of the engine depending upon which filler port is most convenient.
Starter Motor (Optional)	If the engine is equipped with the electric starting option, the starter motor is powered by the battery. When you turn the key switch to the START position, the starter motor engages with the ring gear installed on the flywheel and starts the flywheel in motion.

DIESEL FUEL

Diesel Fuel Specifications

Diesel fuel should comply with the following specifications. The table lists several worldwide specifications for diesel fuels.

Diesel Fuel Specification	Location
No. 2-D, No. 1-D, ASTM D975-94	USA
EN590:96	European Union
ISO 8217 DMX	International
BS 2869-A1 or A2	United Kingdom
JIS K2204 Grade No. 2	Japan
KSM-2610	Korea
GB252	China

Additional Technical Fuel Requirements

- The fuel cetane number should be equal to 45 or higher.
- The sulfur content must not exceed 0.5% by volume. Less than 0.05% is preferred.
- Bio-Diesel fuels. *See Bio-Diesel Fuels on page 4-9.*
- NEVER mix kerosene, used engine oil, or residual fuels with the diesel fuel.
- The water and sediment in the fuel should not exceed 0.05% by volume.
- Keep the fuel tank and fuel-handling equipment clean at all times.
- Poor quality fuel can reduce engine performance and / or cause engine damage.
- Fuel additives are not recommended. Some fuel additives may cause poor engine performance. Consult your Yanmar representative for more information.
- The ash content must not exceed 0.01% by volume.

- The carbon residue content must not exceed 0.35% by volume. Less than 0.1% is preferred.
- The total aromatics content should not exceed 35% by volume. Less than 30% is preferred.
- The PAH (polycyclic aromatic hydrocarbons) content should be below 10% by volume.
- The metal content of Na, Mg, Si, and Al should be equal to or lower than 1 mass ppm. (Test analysis method JPI-5S-44-95)
- Lubricity: The wear mark of WS1.4 should be Max. 0.018 in (460 µm) at HFRR test.

Bio-Diesel Fuels

In Europe and in the United States, as well as some other countries, non-mineral oil based fuel resources such as RME (Rapeseed Methyl Ester) and SOME (Soybean Methyl Ester), collectively known as FAME (Fatty Acid Methyl Esters), are being used as extenders for mineral oil derived diesel fuels.

Yanmar approves the use of bio-diesel fuels that do not exceed a blend of 5% (by volume) of FAME with 95% (by volume) of approved mineral oil derived diesel fuel. Such bio-diesel fuels are known in the marketplace as B5 diesel fuels.

These B5 diesel fuels must meet certain requirements.

1. The bio-fuels must meet the minimum specifications for the country in which they are used.
 - In Europe, bio-diesel fuels must comply with the European Standard EN14214.
 - In the United States, bio-diesel fuels must comply with the American Standard ASTM D-6751.
2. Bio-fuels should be purchased only from recognized and authorized diesel fuel suppliers.

GENERAL SERVICE INFORMATION

Precautions and concerns regarding the use of bio-fuels:

1. Free methanol in FAME may result in corrosion of aluminum and zinc FIE components.
2. Free water in FAME may result in plugging of fuel filters and increased bacterial growth.
3. High viscosity at low temperatures may result in fuel delivery problems, injection pump seizures, and poor injection nozzle spray atomization.
4. FAME may have adverse effects on some elastomers (seal materials) and may result in fuel leakage and dilution of the engine lubricating oil.
5. Even bio-diesel fuels that comply with a suitable standard as delivered, will require additional care and attention to maintain the quality of the fuel in the equipment or other fuel tanks. It is important to maintain a supply of clean, fresh fuel. Regular flushing of the fuel system, and / or fuel storage containers, may be necessary.
6. The use of bio-diesel fuels that do not comply with the standards as agreed to by the diesel engine manufacturers and the diesel fuel injection equipment manufacturers, or bio-diesel fuels that have degraded as per the precautions and concerns above, may affect the warranty coverage of your engine. See *Yanmar Limited Warranty on page 2-3.*

Filling the Fuel Tank

 **DANGER**



FIRE AND EXPLOSION HAZARD!

- Diesel fuel is flammable and explosive under certain conditions.
- **ALWAYS** fill the fuel tank only with specified diesel fuel. Filling the fuel tank with gasoline may result in a fire and will damage the engine.
- **NEVER** refuel with the engine running.
- **ALWAYS** wipe up all spills immediately.
- **ALWAYS** keep sparks, open flames or any other form of ignition (match, cigarette, static electric source) well away when refueling.
- **NEVER** overfill the fuel tank.
- **Store** any containers containing fuel in a well-ventilated area, away from any combustibles or sources of ignition.
- **Failure to comply will result in death or serious injury.**

0000005en

! DANGER**FIRE AND EXPLOSION HAZARD!**

- Diesel fuel is flammable and explosive under certain conditions.
- Be sure to place the diesel fuel container on the ground when transferring the diesel fuel from the pump to the container. Hold the hose nozzle firmly against the side of the container while filling. This prevents static electricity buildup which could cause sparks and ignite fuel vapors.
- NEVER place diesel fuel or other flammable material such as oil, hay or dried grass close to the engine during engine operation or shortly after shut down.
- Never inject fuel toward a fire source. Atomized fuel is highly flammable and may cause a fire or burn skin.
- Failure to comply will result in death or serious injury.

0000014enT80

! DANGER**FIRE AND EXPLOSION HAZARD!**

- Diesel fuel is flammable and explosive under certain conditions.
- ALWAYS check for fuel leaks before you operate the engine. Replace rubberized fuel hoses every two years or every 2000 hours of engine operation, whichever comes first, even if the engine has been out of service. Rubberized fuel lines tend to dry out and become brittle after two years or 2000 hours of engine operation, whichever comes first.
- Failure to comply will result in death or serious injury.

0000015en

CAUTION

- Only use diesel fuels recommended by Yanmar for the best engine performance, to prevent engine damage.
- Only use clean diesel fuel.
- NEVER remove inlet fuel screen from the filler port. If removed, dirt and debris could get into the fuel system causing blockage or damage to the fuel system components.

0000004enLN

GENERAL SERVICE INFORMATION

Note: A typical fuel tank is shown in **Figure 4-3**. The fuel tank on your engine may be different. The inlet fuel screen is shown removed from the fuel tank for clarity. ALWAYS make sure the inlet fuel screen remains inside of the fuel tank while fueling.

1. Clean the area around the fuel cap (**Figure 4-3, (1)**).
2. Remove the fuel cap from the fuel tank (**Figure 4-3, (3)**).
3. Stop fueling when the fuel is at the same level as the red ring (**Figure 4-3, (4)**) at the bottom of the inlet fuel screen (**Figure 4-3, (2)**). NEVER overfill the fuel tank. Overfilling the fuel tank may allow contaminated fuel to bypass the intake fuel filter by entering through the air bleed hole in the top of the fuel filter.
4. Replace the fuel cap and hand-tighten. Over-tightening the fuel cap will damage it.

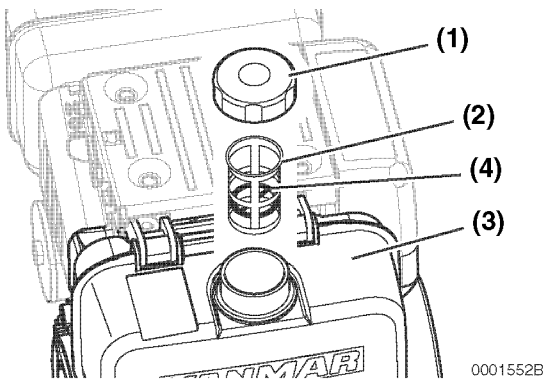

Figure 4-3

Priming the Fuel System

⚠ DANGER



FIRE AND EXPLOSION HAZARD!

- Diesel fuel is extremely flammable and explosive under certain conditions.
- The procedures used to prime gravity-fed fuel systems and fuel systems pressurized by an electric pump are different.
- Place an approved container under the high-pressure line fitting when you prime the fuel system. NEVER use a shop rag to catch the fuel. Wipe up any spills immediately.
- Wear eye protection. The fuel system is under pressure and fuel could spray out when you open the high-pressure line fitting.
- Failure to comply will result in death or serious injury.

000006enlva

The fuel system needs to be primed under certain conditions:

- Before starting the engine for the first time.
- After running out of fuel and fuel has been added to the fuel tank.
- After fuel system maintenance such as changing the fuel filter and draining the fuel filter / water separator, or replacing a fuel system component.

The procedures used to prime gravity-fed fuel systems and fuel systems pressurized by an electric pump are different. Use the following appropriate procedure for the system being serviced.

Gravity-Fed Fuel System

1. Place the engine speed control lever in the HIGH-IDLE position.
2. Open all fuel supply valves. Allow 20 - 30 seconds for fuel to reach the fuel injection pump.
3. Loosen the high pressure fuel injection line nut at the fuel injector fitting approximately 1/2 turn.
4. Set and hold the compression release lever in the RELEASE position.
5. Using the recoil starter, crank the engine until the fuel coming out of the fuel injector fitting is free of bubbles.

IMPORTANT

NEVER use the starter motor to crank the engine in order to prime the fuel system. This may cause the starter motor to overheat and damage the coils, pinion and / or ring gear.

6. Tighten the high pressure fuel injection line nut. See *Special Torque Specifications on page 7-4.*

Electric Pump Pressurized Fuel System

IMPORTANT

NEVER use the starter motor to crank the engine in order to prime the fuel system. This may cause the starter motor to overheat and damage the coils, pinion and / or ring gear.

1. Place the engine speed control lever in the HIGH-IDLE position.
2. Open all fuel supply valves.
3. Turn the key switch to the "ON" position for 10 - 15 seconds to allow the electric fuel pump to prime the fuel system to the fuel injection pump.
4. Loosen the high pressure fuel injection line nut at the fuel injector fitting approximately 1/2 turn.
5. Set and hold the compression release lever in the RELEASE position.

IMPORTANT

NEVER use the starter motor to crank the engine in order to prime the fuel system. This may cause the starter motor to overheat and damage the coils, pinion and / or ring gear.

6. Using the recoil starter, crank the engine until the fuel coming out of the fuel injector fitting is free of bubbles.
7. Tighten the high pressure fuel injection line nut. See *Special Torque Specifications on page 7-4.*

ENGINE OIL

CAUTION

- **ALWAYS** use only the engine oil specified. Other engine oils may affect warranty coverage, cause internal engine components to seize and / or shorten engine life.
- **ALWAYS** prevent dirt and debris from contaminating the engine oil. Carefully clean the oil cap / dipstick and the surrounding area before you remove the cap.
- **NEVER** mix different types of engine oil. This may adversely affect the lubricating properties of the engine oil.
- **NEVER** overfill. Overfilling may result in white exhaust smoke, engine overspeed or internal damage.

000005en

Engine Oil Specifications

Use an engine oil that meets or exceeds the following guidelines and classifications:

Service Categories

- API Service Categories CD or higher
- ACEA Service Categories E-3, E-4, and E-5
- JASO Service Category DH-1

Definitions

- API Classification [American Petroleum Institute]
- ACEA Classification [Association des Constructeurs Européens d'Automobiles]
- JASO [Japanese Automobile Standards Organization]

Note:

- Be sure the engine oil, engine oil storage containers, and engine oil filling equipment are free of sediments and water.
- Change the engine oil after the first 50 hours of operation and then at every 250 hours thereafter.
- Select the oil viscosity based on the ambient temperature where the engine is being operated. See the SAE Service Grade Viscosity Chart (**Figure 4-4**).
- Yanmar does not recommend the use of engine oil "additives."

Additional Technical Engine oil Requirements:

The engine oil must be changed when the Total Base Number (TBN) has been reduced to 2.0. TBN (mgKOH/g) test method; JIS K-201-5.2-2 (HCl), ASTM D4739 (HCl).

Engine Oil Viscosity

Select the appropriate engine oil viscosity based on the ambient temperature and use the SAE Service Grade Viscosity Chart in **Figure 4-4**.

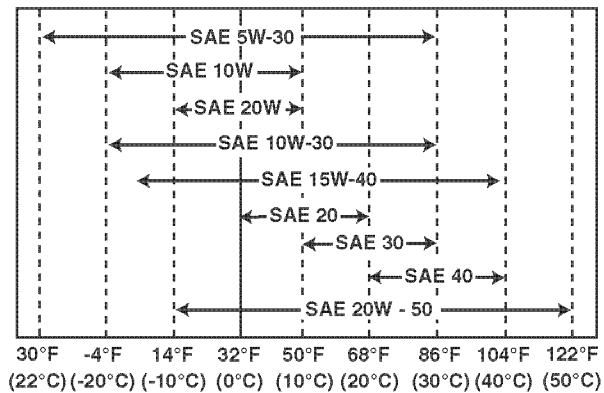

000005C

Figure 4-4

Engine Oil Capacity (Typical)

Note: Oil capacity will vary depending upon which optional oil pan is used. Refer to the operation manual provided by the driven machine manufacturer for the actual engine oil capacity of your machine.

The following are the engine oil capacities for various Yanmar LN Series engines.

Engine Model	Dipstick Upper Limit/ Lower Limit
L48N	0.85 / 0.58 qt (0.80 / 0.55 L)
L70N	1.11 / 0.69 qt (1.05 / 0.65 L)
L100N	1.70 / 1.06 qt (1.60 / 1.00 L)

Checking Engine Oil

1. Make sure engine is level.
2. Remove oil cap / dipstick (**Figure 4-5, (1)**) (**Figure 4-6, (1)**) from either location and wipe with clean cloth.
3. Reinsert oil cap / dipstick into the crankcase and turn clockwise for one half revolution to engage the first thread in the crankcase opening.
4. Remove oil cap / dipstick. The oil level should be between upper (**Figure 4-5, (2)**) and lower (**Figure 4-5, (3)**) lines on the oil cap / dipstick.
5. Fully reinsert oil cap / dipstick and hand-tighten. Over-tightening the oil cap / dipstick will damage it.

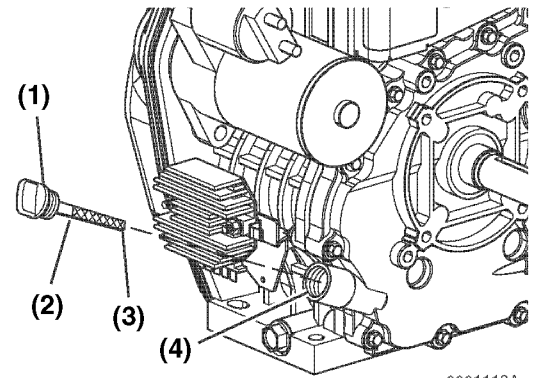

0001119A

Figure 4-5

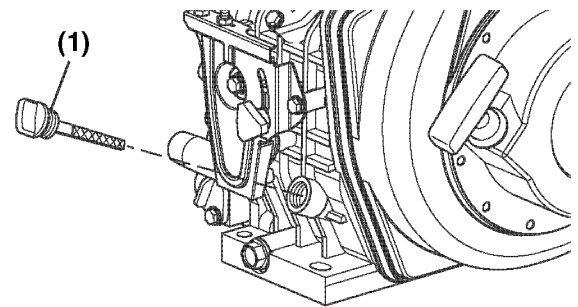

0001566A

Figure 4-6

Adding Engine Oil

1. Make sure engine is level.
2. Remove oil cap / dipstick (**Figure 4-5, (1)**) (**Figure 4-6, (1)**).
3. Add indicated amount of engine oil at either of the engine oil filler ports (**Figure 4-6, (4)**).
4. Wait one minute and check oil level.

IMPORTANT

NEVER overfill engine with oil. Engine damage will result.

5. Add more oil if necessary.
6. Fully reinsert oil cap / dipstick and hand-tighten. Over-tightening the oil cap / dipstick will damage it.

GENERAL SERVICE INFORMATION

ABBREVIATIONS AND SYMBOLS

Abbreviations

A	ampere
AC	alternating current
ACEA	Association des Constructeurs Européens d'Automobilies
Ah	ampere-hour
API	American Petroleum Institute
ARB	Air Resources Board
ATDC	after top dead center
BDC	bottom dead center
BTDC	before top dead center
°C	degree Celsius
CARB	California Air Resources Board
CCA	cold cranking amp
cfm	cubic feet per minute
cm	centimeter
cm³	cubic centimeter
cm³/min	cubic centimeter per minute
cu in.	cubic inch
D	diameter
DC	direct current
DI	direct injection
DVA	direct volt adapter
EPA	Environmental Protection Agency
ESG	electronic speed governor
°F	degree Fahrenheit
fl oz	fluid ounce (U.S.)
fl oz/min	fluid ounce (U.S.) per minute
ft	foot
ft-lb	foot pound
ft-lbf/min	foot pound force per minute
g	gram
gal	gallon (U.S.)
gal/hr	gallon (U.S.) per hour
gal/min	gallon (U.S.) per minute
GL	gear lubricant
hp	horsepower (U.S.)
hr	hour
I.D.	inside diameter
ID	identification
IDI	indirect injection
in.	inch
in.Aq	inches Aqueous (water)
in.Hg	inches Mercury
in.-lb	inch pound
j	joule

JASO	Japanese Automobile Standards Organization
k	kelvin
kg	kilogram
kgf/cm²	kilogram force per square centimeter
kgf·m	kilogram force per meter
km	kilometers
kPa	kilopascal
kW	kilowatt
L	liter
L/hr	liter per hour
lb	pound
lb-ft	pound foot
lb-in.	pound inch
lbf	pound force
m	meter
mL	milliliter
mm	millimeter
mmAq	millimeter Aqueous (water)
MPa	megapascal
mV	millivolt
N	newton
N·m	newton meter
No.	number
O.D.	outside diameter
oz	ounce
Pa	pascal
PS	horsepower (metric)
psi	pound per square inch
qt	quart (U.S.)
R	radius
rpm	revolutions per minute
SAE	Society of Automotive Engineers
sec.	second
t	short ton 2000 lb
TBN	total base number
TDC	top dead center
V	volt
VAC	volt alternating current
VDC	volt direct current
W	watt

Symbols

°	degree
+	plus
-	minus
±	plus or minus
Ω	ohm
μ	micro
%	percent

UNIT CONVERSIONS

Unit Prefixes

Prefix	Symbol	Power
mega	M	x 1,000,000
kilo	k	x 1,000
centi	c	x 0.01
milli	m	x 0.001
micro	μ	x 0.000001

Units of Length

mile	x	1.6090	= km
ft	x	0.3050	= m
in.	x	2.5400	= cm
in.	x	25.4000	= mm
km	x	0.6210	= mile
m	x	3.2810	= ft
cm	x	0.3940	= in.
mm	x	0.0394	= in.

Units of Volume

gal (U.S.)	x	3.78540	= L
qt (U.S.)	x	0.94635	= L
cu in.	x	0.01639	= L
cu in.	x	16.38700	= mL
fl oz (U.S.)	x	0.02957	= L
fl oz (U.S.)	x	29.57000	= mL
cm ³	x	1.00000	= mL
cm ³	x	0.03382	= fl oz (U.S.)

Units of Mass

lb	x	0.45360	= kg
oz	x	28.35000	= g
kg	x	2.20500	= lb
g	x	0.03527	= oz

Units of Force

lbf	x	4.4480	= N
lbf	x	0.4536	= kgf
N	x	0.2248	= lbf
N	x	0.1020	= kgf
kgf	x	2.2050	= lbf
kgf	x	9.8070	= N

Units of Torque

ft-lb	x	0.1383	= kgf·m
in.-lb	x	0.0115	= kgf·m
lb-ft	x	1.3558	= N·m
lb-ft	x	0.1383	= kgf·m
lb-in.	x	0.1130	= N·m
lb-in.	x	0.0115	= kgf·m
kgf·m	x	7.2330	= lb-ft
kgf·m	x	86.8000	= lb-in.
kgf·m	x	9.8070	= N·m
N·m	x	0.7376	= lb-ft
N·m	x	8.8510	= lb-in.
N·m	x	0.1020	= kgf·m

Units of Pressure

psi	x	0.0689	= bar
psi	x	6.8950	= kPa
psi	x	0.0703	= kg/cm ²
bar	x	14.5030	= psi
bar	x	100.0000	= kPa
bar	x	29.5300	= inHg (60°F)
kPa	x	0.1450	= psi
kPa	x	0.0100	= bar
kPa	x	0.0102	= kg/cm ²
kg/cm ²	x	98.0700	= psi
kg/cm ²	x	0.9807	= bar
kg/cm ²	x	14.2200	= kPa
in.Hg (60°)	x	0.0333	= bar
in.Hg (60°)	x	3.3770	= kPa
in.Hg (60°)	x	0.0344	= kg/cm ²
mmAq	x	0.0394	= in.Aq

Units of Power

hp (metric or PS)	x	0.9863201	= hp SAE
hp (metric or PS)	x	0.7354988	= kW
hp SAE	x	1.0138697	= hp (metric or PS)
hp SAE	x	0.7456999	= kW
kW	x	1.3596216	= hp (metric or PS)
kW	x	1.3410221	= hp SAE

Units of Temperature

$$^{\circ}\text{F} = (1.8 \times ^{\circ}\text{C}) + 32$$

$$^{\circ}\text{C} = 0.556 \times (^{\circ}\text{F} - 32)$$

GENERAL SERVICE INFORMATION

TIGHTENING TORQUES FOR STANDARD BOLTS AND NUTS

Use the correct amount of torque when you tighten fasteners on the machine. Applying excessive torque may damage the fastener or component and not enough torque may cause a leak or component failure.

Torque values shown in this manual are for clean, non-lubricated fasteners unless otherwise specified.

CAUTION

The tightening torque in the Standard Torque Chart should be applied only to the bolts with a "7" head. (JIS strength classification: 7T)

- Apply 60% torque to bolts that are not listed.
- Apply 80% torque when tightened to aluminum alloy.



0000023en

Item	Nominal Thread Diameter x Pitch	Tightening Torque	Remarks
Hexagon Bolt (7T) and Nut	M6 x 1.0 mm	7 - 9 lb-ft (87 - 104 lb-in., 9.8 - 11.8 N·m, 1.0 - 1.2 kgf·m)	Use 80% of the value at left when the tightening part is aluminum. Use 60% of the value at left for 4T bolts and locknuts.
	M8 x 1.25 mm	17 - 21 lb-ft (200 - 251 lb-in., 22.6 - 28.4 N·m, 2.3 - 2.9 kgf·m)	
	M10 x 1.5 mm	33 - 40 lb-ft (44.1 - 53.9 N·m, 4.5 - 5.5 kgf·m)	
	M12 x 1.75 mm	58 - 72 lb-ft (78.4 - 98.0 N·m, 8.0 - 10 kgf·m)	
	M14 x 1.5 mm	94 - 108 lb-ft (127.5 - 147.1 N·m, 13 - 15 kgf·m)	
	M16 x 1.5 mm	159 - 174 lb-ft (215.7 - 235.4 N·m, 22 - 24 kgf·m)	
PT Plug	1/8 mm	7 lb-ft (87 lb-in., 9.8 N·m, 1.0 kgf·m)	-
	1/4 mm	14 lb-ft (173 lb-in., 19.6 N·m, 2.0 kgf·m)	
	3/8 mm	22 lb-ft (29.4 N·m, 3.0 kgf·m)	
	1/2 mm	43 lb-ft (58.8 N·m, 6.0 kgf·m)	

GENERAL SERVICE INFORMATION

Item	Nominal Thread Diameter x Pitch	Tightening Torque	Remarks
Pipe Joint Bolt	M8	9 - 12 lb-ft (112 - 148 lb-in., 12.7 - 16.7 N·m, 1.3 - 1.7 kgf·m)	-
	M10	14 - 19 lb-ft (173 - 225 lb-in., 19.6 - 25.4 N·m, 2.0 - 2.5 kgf·m)	
	M12	18 - 25 lb-ft (24.5 - 34.3 N·m, 2.5 - 3.5 kgf·m)	
	M14	29 - 36 lb-ft (39.2 - 49.0 N·m, 4.0 - 5.0 kgf·m)	
	M16	36 - 43 lb-ft (49.0 - 58.8 N·m, 5.0 - 6.0 kgf·m)	

GENERAL SERVICE INFORMATION

TIGHTENING TORQUES FOR SPECIAL BOLTS AND NUTS

Component	Model	Thread Diameter and Pitch	Torque	Lubricating Oil Application (Thread Portion and Seat Surface)	Reference Page
Crankcase Cover Bolt	L48N	14-M6 x 1.0 mm	96 - 114 lb-in. (10.8 - 12.8 N·m, 1.1 - 1.3 kgf·m)	Not Applied	-
	L70N, L100N	13-M8 x 1.25 mm	225 - 243 lb-in. (25.5 - 27.5 N·m, 2.6 - 2.8 kgf·m)		
Stiffener Bolts on Crankcase Cover	All Models	M8 x 1.25 mm	225 - 242 lb-in. (25.5 - 27.4 N·m, 2.6 - 2.8 kgf·m)	Not Applied	-
Connecting Rod Nuts and Bolts	L48N, L70N	2-M7 x 1.0 mm	200 - 243 lb-in. (22.6 - 27.5 N·m, 2.3 - 2.8 kgf·m)	Applied	-
	L100N	2-M8 x 1.0 mm	27.1 - 31 lb-ft (36.7 - 41.7 N·m, 3.7 - 4.3 kgf·m)		
Flywheel Nut	L48N	M16 x 1.5 mm	101.5 - 108.7 lb-ft (137.3 - 147.1 N·m, 14.0 - 15.0 kgf·m)	Applied	-
	L70N	M16 x 1.5 mm	116 - 123.2 lb-ft (156.9 - 166.7 N·m, 16.0 - 17.0 kgf·m)		
	L100N	M18 x 1.5 mm	159 - 166 lb-ft (215.7 - 225.6 N·m, 22.0 - 23.0 kgf·m)		
Cylinder Head Nuts (Final Torque)	L48N	M8 x 1.25 mm	21.5 - 24.4 lb-ft (29.4 - 33.3 N·m, 3.0 - 3.4 kgf·m)	Applied	-
	L70N	M9 x 1.5 mm	34.8 - 37.8 lb-ft (47 - 51 N·m, 4.8 - 5.2 kgf·m)		
	L100N	M10 x 1.25 mm	44.0 - 46.9 lb-ft (59.8 - 63.7 N·m, 6.1 - 6.5 kgf·m)		
Valve Rocker Arm Support	L48N, L70N	M6 x 1.00 mm	88 - 106 lb-in. (10 - 12 N·m, 1.0 - 1.2 kgf·m)	Not Applied	-
	L100N	M8 x 1.5 mm	225 - 243 lb-in. (25.5 - 27.5 N·m, 2.6 - 2.8 kgf·m)	Not Applied	-

GENERAL SERVICE INFORMATION

Component	Model	Thread Diameter and Pitch	Torque	Lubricating Oil Application (Thread Portion and Seat Surface)	Reference Page
Fuel Nozzle Case Nut	All Models	U-0.605-40UNS-2B	30 - 35 lb-ft (40.7 - 47.5 N·m, 4.2 - 4.8 kgf·m)	Not Applied	-
Fuel Pump Delivery Valve (If Equipped)		M14 x 15 mm	22 - 25.8 lb-ft (30 - 35 N·m, 3.0 - 3.6 kgf·m)	Not Applied	-
Fuel Injection Pump Nuts		3-M6 x 1.0 mm	7.4 - 8.9 lb-in. (10 - 12 N·m, 1.02 - 1.22 kgf·m)	Not Applied	-
Fuel Injection Nozzle Nuts		2-M6 x 1.0 mm	61.3 - 79 lb-in. (6.9 - 8.9 N·m, 0.7 - 0.9 kgf·m)	Not Applied	-
Fuel Injection Pump Inspection Window Plate Nuts		3-M6 x 1.0 mm	87 - 104 lb-in. (9.8 - 11.8 N·m, 1.0 - 1.2 kgf·m)	Not Applied	-
Fuel Limiter Mounting Nut		-	215 - 218 in.-lb (24.2 - 24.6 N·m, 2.4 - 2.5 kgf·m)	Not Applied	-
High Pressure Fuel Injection Line Nuts		-	19.8 - 23.5 lb-ft (26.9 - 31.9 N·m, 2.7 - 3.3 kgf·m)	Not Applied	-

This Page Intentionally Left Blank

Section 5



PERIODIC MAINTENANCE



	Page
Before You Begin Servicing	5-3
Introduction.....	5-13
The Importance of Periodic Maintenance.....	5-13
Performing Periodic Maintenance	5-13
The Importance of Daily Checks	5-14
Keep a Log of Engine Hours and Daily Checks	5-14
Yanmar Replacement Parts	5-14
Tools Required	5-14
Tightening Fasteners.....	5-14
Periodic Maintenance Schedule.....	5-15
Periodic Maintenance Procedures	5-17
Daily, Before Operation	5-17
Daily, After Operation	5-24
After Initial 50 Hours of Operation	5-25
Every 50 Hours of Operation	5-28
Every 200 Hours of Operation	5-29
Every 500 Hours of Operation	5-35
Every 1000 Hours of Operation	5-36
Every 2000 Hours of Operation	5-36

This Page Intentionally Left Blank

BEFORE YOU BEGIN SERVICING

Before performing any service procedures within this section, read the following safety information and review the *Safety* section on page 3-1.

 DANGER

<p style="text-align: center;">EXPLOSION HAZARD!</p> <ul style="list-style-type: none"> • NEVER check the remaining battery charge by shorting out the terminals. This will result in a spark and may cause an explosion or fire. Use a hydrometer to check the remaining battery charge. • If the electrolyte is frozen, slowly warm the battery before you recharge it. • Failure to comply will result in death or serious injury. <p style="text-align: right; font-size: small;">000007en</p>

 DANGER

<p style="text-align: center;">FIRE AND EXPLOSION HAZARD!</p> <ul style="list-style-type: none"> • Diesel fuel is flammable and explosive under certain conditions. • NEVER remove the fuel cap with the engine running. • Failure to comply will result in death or serious injury. <p style="text-align: right; font-size: small;">0000011en</p>

 DANGER

<p style="text-align: center;">FIRE AND EXPLOSION HAZARD!</p> <ul style="list-style-type: none"> • Diesel fuel is flammable and explosive under certain conditions. • ALWAYS fill the fuel tank only with specified diesel fuel. Filling the fuel tank with gasoline may result in a fire and will damage the engine. • NEVER refuel with the engine running. • ALWAYS wipe up all spills immediately. • ALWAYS keep sparks, open flames or any other form of ignition (match, cigarette, static electric source) well away when refueling. • NEVER overfill the fuel tank. • Store any containers containing fuel in a well-ventilated area, away from any combustibles or sources of ignition. • Failure to comply will result in death or serious injury. <p style="text-align: right; font-size: small;">000005en</p>

 DANGER

<p style="text-align: center;">FIRE AND EXPLOSION HAZARD!</p> <ul style="list-style-type: none"> • Diesel fuel is flammable and explosive under certain conditions. • NEVER use diesel fuel as a cleaning agent. • Failure to comply will result in death or serious injury. <p style="text-align: right; font-size: small;">0000012en</p>

DANGER



FIRE AND EXPLOSION HAZARD!

- Diesel fuel is flammable and explosive under certain conditions.
- **ALWAYS** check for fuel leaks before you operate the engine. Replace rubberized fuel hoses every two years or every 2000 hours of engine operation, whichever comes first, even if the engine has been out of service. Rubberized fuel lines tend to dry out and become brittle after two years or 2000 hours of engine operation, whichever comes first.
- Failure to comply will result in death or serious injury.

0000015en

DANGER



CRUSH HAZARD!

- When you need to transport an engine for repair, have a helper assist you to attach it to a hoist and load it on a truck.
- **NEVER** stand under a hoisted engine. If the hoist mechanism fails, the engine will fall on you, causing death or serious injury.
- Failure to comply will result in death or serious injury.

0000008en

DANGER



FIRE AND EXPLOSION HAZARD!

- Diesel fuel is flammable and explosive under certain conditions.
- Be sure to place the diesel fuel container on the ground when transferring the diesel fuel from the pump to the container. Hold the hose nozzle firmly against the side of the container while filling. This prevents static electricity buildup which could cause sparks and ignite fuel vapors.
- **NEVER** place diesel fuel or other flammable material such as oil, hay or dried grass close to the engine during engine operation or shortly after shut down.
- Never inject fuel toward a fire source. Atomized fuel is highly flammable and may cause a fire or burn skin.
- Failure to comply will result in death or serious injury.

0000014enT80

! DANGER



FIRE AND EXPLOSION HAZARD!

- Only use the key switch to start the engine.
- NEVER jump-start the engine. Sparks caused by shorting the battery to the starter terminals may cause a fire or explosion.
- Failure to comply will result in death or serious injury.

000004en

! DANGER



FIRE AND EXPLOSION HAZARD!

- Diesel fuel is flammable and explosive under certain conditions.
- ALWAYS put an approved container under any opening to catch the fuel when removing any fuel system component to perform maintenance (such as changing the fuel filter).
- NEVER use a shop rag to catch the fuel. Vapors from the rag are flammable and explosive.
- ALWAYS wipe up any spills immediately.
- ALWAYS wear eye protection. The fuel system is under pressure and fuel could spray out when you remove any fuel system component.
- Failure to comply will result in death or serious injury.

000009en

! WARNING



EXHAUST HAZARD!

- NEVER operate the engine in an enclosed area such as a garage, tunnel, underground room, manhole or ship's hold without proper ventilation.
- NEVER block windows, vents, or other means of ventilation if the engine is operating in an enclosed area. All internal combustion engines create carbon monoxide gas during operation. Accumulation of this gas within an enclosure could cause illness or even death.
- Make sure that all connections are tightened to specifications after repair is made to the exhaust system.
- Failure to comply could result in death or serious injury.

000003en

WARNING



BURN HAZARD!

- NEVER touch hot engine surfaces such as the muffler, exhaust pipe, turbocharger (if equipped) and engine block during operation and shortly after you shut the engine down. These surfaces are extremely hot while the engine is operating and could seriously burn you.
- Failure to comply could result in death or serious injury.

0000015en

WARNING



SHOCK HAZARD!

- ALWAYS turn off the battery switch (if equipped) or disconnect the negative battery cable before servicing the electrical system.
- Check the electrical harnesses for cracks, abrasions, and damaged or corroded connectors. ALWAYS keep the connectors and terminals clean.
- Failure to comply could result in death or serious injury.

0000009en

WARNING



SEVER HAZARD!

- Keep hands and other body parts away from moving / rotating parts such as the cooling fan / flywheel.
- Wear tight-fitting clothing and keep your hair short or tie it back while the engine is running.
- Remove all jewelry before you operate or service the machine.
- NEVER start the engine in gear. Sudden movement of the engine and / or machine could cause death or serious personal injury.
- NEVER operate the engine without the guards in place.
- Before you start the engine make sure that all bystanders are clear of the area.
- Keep children and pets away while the engine is operating.
- Check before starting the engine that any tools or shop rags used during maintenance have been removed from the area.
- Failure to comply could result in death or serious injury.

0000002enLV

⚠ WARNING

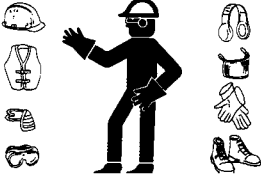

EXPOSURE HAZARD!

- **ALWAYS** wear personal protective equipment such as gloves, work shoes, eye and hearing protection as required by the task at hand.
- **NEVER** wear jewelry, unbuttoned cuffs, ties or loose-fitting clothing when you are working near moving / rotating parts such as the cooling fan, flywheel or PTO shaft.
- **ALWAYS** tie back long hair when you are working near moving / rotating parts such as a cooling fan, flywheel, or PTO shaft.
- **NEVER** operate the engine while wearing a headset to listen to music or radio because it will be difficult to hear the alert signals.
- Failure to comply could result in death or serious injury.

000005en

⚠ WARNING



BURN HAZARD!

- Batteries contain sulfuric acid. **NEVER** allow battery fluid to come in contact with clothing, skin or eyes. Severe burns could result. **ALWAYS** wear safety goggles and protective clothing when servicing the battery. If battery fluid contacts the eyes and / or skin, immediately flush the affected area with a large amount of clean water and obtain prompt medical treatment.
- Failure to comply could result in death or serious injury.

000007en

⚠ WARNING



ENTANGLEMENT HAZARD!

- **ALWAYS** stop the engine before you begin to service it.
- **NEVER** leave the key in the key switch when you are servicing the engine. Someone may accidentally start the engine and not realize you are servicing it.
- Failure to comply could result in death or serious injury.

000010en

⚠ WARNING



HIGH-PRESSURE HAZARD!

- Avoid skin contact with the high-pressure diesel fuel spray caused by a fuel system leak such as a broken fuel injection line. High-pressure fuel can penetrate your skin and result in serious injury. If you are exposed to high-pressure fuel spray, obtain prompt medical treatment.
- NEVER check for a fuel leak with your hands. ALWAYS use a piece of wood or cardboard. Have your authorized Yanmar industrial engine dealer or distributor repair the damage.
- Failure to comply could result in death or serious injury.

000008en

⚠ WARNING



BURN HAZARD!

- ALWAYS stay clear of the hot engine oil to avoid being burned.
- ALWAYS wear eye protection.
- Failure to comply could result in serious injury.

0000011en

⚠ WARNING



ALCOHOL AND DRUG HAZARD!

- NEVER operate the engine while you are under the influence of alcohol or drugs.
- NEVER operate the engine when you are feeling ill.
- Failure to comply could result in death or serious injury.

000004en

⚠ CAUTION



FLYING OBJECT HAZARD!

- ALWAYS wear eye protection when servicing the engine and when using compressed air or high-pressure water. Dust, flying debris, compressed air, pressurized water or steam may injure your eyes.
- Failure to comply may result in minor or moderate injury.

000003en

CAUTION

- Only use diesel fuels recommended by Yanmar for the best engine performance, to prevent engine damage.
- Only use clean diesel fuel.
- NEVER remove inlet fuel screen from the filler port. If removed, dirt and debris could get into the fuel system causing blockage or damage to the fuel system components.

000004enLN

CAUTION

NEVER hold the key in the START position for longer than 15 seconds or the starter motor will overheat.

000007en

CAUTION

- ALWAYS use only the engine oil specified. Other engine oils may affect warranty coverage, cause internal engine components to seize and / or shorten engine life.
- ALWAYS prevent dirt and debris from contaminating the engine oil. Carefully clean the oil cap / dipstick and the surrounding area before you remove the cap.
- NEVER mix different types of engine oil. This may adversely affect the lubricating properties of the engine oil.
- NEVER overfill. Overfilling may result in white exhaust smoke, engine overspeed or internal damage.

000005en

CAUTION

NEVER use an engine starting aid such as ether. Engine damage will result.

000009en

CAUTION

- NEVER attempt to modify the engine's design or safety features such as defeating the engine speed limit control or the fuel injection quantity control.
- Failure to comply may impair the engine's safety and performance characteristics and shorten the engine's life. Any alterations to this engine may affect the warranty coverage of your engine. *See Yanmar Limited Warranty in Warranty Section.*

000044enTNVDISM

CAUTION

Observe the following environmental operating conditions to maintain engine performance and avoid premature engine wear:

- Avoid operating in extremely dusty conditions.
- Avoid operating in the presence of chemical gases or fumes.
- Avoid operating in a corrosive atmosphere such as salt water spray.
- NEVER install the engine in a floodplain unless proper precautions are taken to avoid being subject to a flood.
- NEVER expose the engine to the rain.

000003en

CAUTION

For maximum engine life, Yanmar recommends that when shutting the engine down, allow the engine to idle, without load, for five minutes. This will allow the engine components that operate at high temperatures, such as the turbocharger (if equipped) and exhaust system, to cool slightly before the engine itself is shut down.

000008en

CAUTION

- NEVER overfill the engine with engine oil.
- ALWAYS keep the oil level between the upper and lower lines on the oil cap / dipstick.

0000015en

CAUTION

Observe the following environmental operating conditions to maintain engine performance and avoid premature engine wear:

- The standard range of ambient temperatures for the normal operation of Yanmar engines is from +5°F (-15°C) to +113°F (+45°C).
- If the ambient temperature exceeds +113°F (+45°C) the engine may overheat and cause the engine oil to break down.
- If the ambient temperature is below +5°F (-15°C) the engine will be hard to start and the engine oil may not flow easily.
- Contact your authorized Yanmar industrial engine dealer or distributor if the engine will be operated outside of this standard temperature range.

0000065en

CAUTION

ALWAYS protect the air cleaner, turbocharger (if equipped) and electric components from damage when you use steam or high-pressure water to clean the engine.

0000014en

CAUTION

Make sure the engine is installed on a level surface. If a continuously running engine is installed at an angle greater than 20° (in any direction) or if an engine runs for short periods of time (less than three minutes) at an angle greater than 25° in any direction, engine oil may enter the combustion chamber causing excessive engine speed and generate white smoke. This may cause serious engine damage.

0000010enTNE

CAUTION

It is important to perform daily checks. Periodic maintenance prevents unexpected downtime, reduces the number of accidents due to poor machine performance and helps extend the life of the engine.

0000060en

CAUTION

NEVER engage the starter motor while the engine is running. This may damage the starter motor pinion and / or ring gear.

0000012en

CAUTION

- When the engine is operated in dusty conditions, clean the air cleaner element more frequently.
- NEVER operate the engine with the air cleaner element(s) removed. This may allow foreign material to enter the engine and damage it.

0000026en

CAUTION

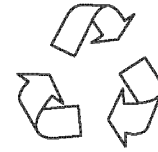

- ALWAYS be environmentally responsible.
- Follow the guidelines of the governmental agencies for the proper disposal of hazardous materials such as engine oil, diesel fuel and engine coolant. Consult the local authorities or reclamation facility.
- NEVER dispose of hazardous materials irresponsibly by dumping them into a sewer, on the ground, or into ground water or waterways.
- Failure to follow these procedures may seriously harm the environment.

0000013enLN

CAUTION

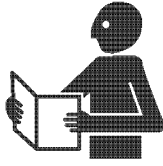

NEVER permit anyone to operate the engine or driven machine without proper training.

- Read and understand this Service Manual before you operate or service the machine to ensure that you follow safe operating practices and maintenance procedures.
- Machine safety signs and labels are additional reminders for safe operating and maintenance techniques.
- See your authorized Yanmar industrial engine dealer or distributor for additional training.

000002enSM

CAUTION

Establish a periodic maintenance plan according to the engine application and make sure you perform the required periodic maintenance at intervals indicated. Failure to follow these guidelines will impair the engine's safety and performance characteristics, shorten the engine's life and may affect the warranty coverage on your engine.

See Yanmar Limited Warranty on page 2-3.

Consult your authorized Yanmar industrial engine dealer or distributor for assistance when checking items marked with a ●.

000024enLVOM

Introduction

This section of the *Service Manual* describes the procedures for proper care and maintenance of the engine.

The Importance of Periodic Maintenance

Engine deterioration and wear occurs in proportion to the length of time the engine has been in service and the conditions the engine is subject to during operation. Periodic maintenance prevents unexpected downtime, reduces the number of accidents due to poor machine performance and helps extend the life of the engine.

Performing Periodic Maintenance

WARNING



EXHAUST HAZARD!

- **NEVER** operate the engine in an enclosed area such as a garage, tunnel, underground room, manhole or ship's hold without proper ventilation.
- **NEVER** block windows, vents, or other means of ventilation if the engine is operating in an enclosed area. All internal combustion engines create carbon monoxide gas during operation. Accumulation of this gas within an enclosure could cause illness or even death.
- **Make sure that all connections are tightened to specifications after repair is made to the exhaust system.**
- **Failure to comply could result in death or serious injury.**

000003en

Perform periodic maintenance procedures in an open, level area free from traffic. If possible, perform the procedures indoors to prevent environmental conditions, such as rain, wind or snow, from damaging the machine.

PERIODIC MAINTENANCE

The Importance of Daily Checks

Periodic Maintenance Schedules assume that the daily checks are performed on a regular basis. Make it a habit of performing daily checks before the start of each shift. *See Daily, Before Operation on page 5-17.*

Keep a Log of Engine Hours and Daily Checks

Keep a log of the number of hours the engine is run each day and a log of the daily checks performed. Also note the date, type of repair (e.g., replaced alternator) and parts required for any service needed between the periodic maintenance intervals. Periodic maintenance intervals are every 50, 200, 500, 1000 and 2000 engine hours. Failure to perform periodic maintenance will shorten the life of the engine.

Yanmar Replacement Parts

Yanmar recommends that you use genuine Yanmar parts when replacement parts are needed. Genuine replacement parts help maintain engine performance and ensure long engine life.

Tools Required

Before you start any periodic maintenance procedure, make sure you have the tools you need to perform all of the required tasks.

Tightening Fasteners

Use the correct amount of torque when you tighten fasteners on the machine. Applying excessive torque may damage the fastener or component and not enough torque may cause a leak or component failure. *See Tightening Torques for Standard Bolts and Nuts on page 4-18* for standard hardware torque values.

PERIODIC MAINTENANCE SCHEDULE

Daily and periodic maintenance is important to keep the engine in good operating condition. The following is a summary of maintenance items by periodic maintenance intervals. Periodic maintenance intervals vary depending on engine application, loads, diesel fuel and engine oil used and are hard to establish definitively. The following should be treated only as a general guideline.

CAUTION
<p>Establish a periodic maintenance plan according to the engine application and make sure you perform the required periodic maintenance at intervals indicated. Failure to follow these guidelines will impair the engine's safety and performance characteristics, shorten the engine's life and may affect the warranty coverage on your engine.</p> <p><i>See Yanmar Limited Warranty on page 2-3.</i></p> <p>Consult your authorized Yanmar industrial engine dealer or distributor for assistance when checking items marked with a ●.</p>
0000024enLVOM

○: Check ◇: Replace ●: Contact your authorized Yanmar industrial engine dealer or distributor for these maintenance services.

System	Check Item	Daily	Periodic Maintenance Interval				
			Every 50 hours	Every 200 hours	Every 500 hours	Every 1000 hours	Every 2000 hours
Air Intake	Clean or Replace Air Cleaner Element - May Need More Frequent Service in Dusty Conditions			○			
Cylinder Head	Adjust Intake / Exhaust Valve Clearance				●		
	Check Compression					●	
Electrical Equipment	Check Battery (If Equipped) and Add Water as Necessary	○ before operation					
	Check Battery Indicator (If Equipped) and Other Driven Machine Indicators (If Equipped)	○ when engine is started					
Engine Oil	Check Engine Oil Level and Add Engine Oil as Necessary	○ before operation					
	Drain and Refill Engine Oil			◇ 2nd and after			
	Clean Engine Oil Filter - Replace If Damaged		◇ 1st time	◇ 2nd and after			
	Check for Engine Oil Leakage	○ before and after operation					

PERIODIC MAINTENANCE

○: Check ◇: Replace ●: Contact your authorized Yanmar industrial engine dealer or distributor for these maintenance services.

System	Check Item	Daily	Periodic Maintenance Interval				
			Every 50 hours	Every 200 hours	Every 500 hours	Every 1000 hours	Every 2000 hours
Engine Speed Control	Check for Proper Operation Verify Adjustment	○ 1st time		○ 2nd and after			
Exhaust System	Check Spark Arrester for Clogging (If Equipped)	○ before operation					
Fuel	Check Fuel Tank Level and Add Fuel As Necessary	○ before operation					
	Drain and Clean Fuel Tank			○			
	Clean Inlet Fuel Screen		○				
	Replace Outlet Fuel Filter			○	◇		
	Check for Fuel Leakage	○ before and after operation					
	Check Fuel Injection Nozzle				○		
Hoses	Replace Fuel System Hose(s)						● or every 2 years whichever comes first

PERIODIC MAINTENANCE PROCEDURES

Before performing periodic maintenance procedures, read the complete procedure including safety information.

Daily, Before Operation

Perform the following maintenance daily before operation.

- Check Battery (If Equipped)
- Check Battery Indicator (If Equipped)
- Check Engine Oil Level
- Check for Engine Oil Leakage
- Check Engine Speed Control (First Time Only)
- Check Spark Arrester (If Equipped)
- Check Fuel Level
- Check for Fuel Leakage

Check Battery (If Equipped)

⚠ DANGER



EXPLOSION HAZARD!

- **NEVER** check the remaining battery charge by shorting out the terminals. This will result in a spark and may cause an explosion or fire. Use a hydrometer to check the remaining battery charge.
- If the electrolyte is frozen, slowly warm the battery before you recharge it.
- Failure to comply will result in death or serious injury.

000007en

⚠ WARNING



BURN HAZARD!

- Batteries contain sulfuric acid. **NEVER** allow battery fluid to come in contact with clothing, skin or eyes. Severe burns could result. **ALWAYS** wear safety goggles and protective clothing when servicing the battery. If battery fluid contacts the eyes and / or skin, immediately flush the affected area with a large amount of clean water and obtain prompt medical treatment.
- Failure to comply could result in death or serious injury.

000007en

CAUTION

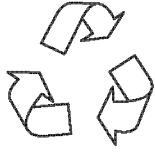

- **ALWAYS** be environmentally responsible.
- Follow the guidelines of the governmental agencies for the proper disposal of hazardous materials such as engine oil, diesel fuel and engine coolant. Consult the local authorities or reclamation facility.
- **NEVER** dispose of hazardous materials irresponsibly by dumping them into a sewer, on the ground, or into ground water or waterways.
- Failure to follow these procedures may seriously harm the environment.

0000013enLN

- If the engine cranking speed is so slow that the engine does not start, recharge the battery.
- If the engine still will not start after charging, have your authorized Yanmar industrial engine dealer or distributor check the battery and the engine's starting system.

If operating the machine where the ambient temperature could drop to 14°F (-10°C) or less, remove the battery from the machine at the end of the day. Store the battery in a warm place until the next use. This will help start the engine easily at low ambient temperatures.

Check Battery Indicator (If Equipped)

Visually check the battery indicator (if equipped) and any other indicator provided by the driven machine manufacturer.

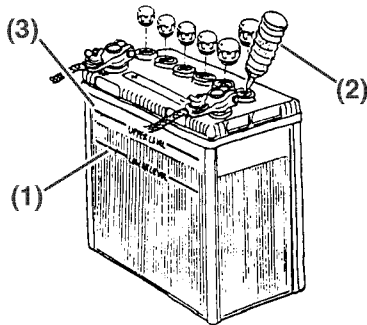

0000067A

Figure 5-1

- When the amount of fluid nears the lower limit (**Figure 5-1, (1)**), fill with distilled water (**Figure 5-1, (2)**) so it is at the upper limit (**Figure 5-1, (3)**). If operation continues with insufficient battery fluid, the battery life is shortened, and the battery may overheat and explode. During the summer, check the fluid level more often than specified.

Check Engine Oil Level

Before you operate the engine check the engine oil level. See *Checking Engine Oil* on page 4-15.

CAUTION
<ul style="list-style-type: none"> • ALWAYS use only the engine oil specified. Other engine oils may affect warranty coverage, cause internal engine components to seize and / or shorten engine life. • ALWAYS prevent dirt and debris from contaminating the engine oil. Carefully clean the oil cap / dipstick and the surrounding area before you remove the cap. • NEVER mix different types of engine oil. This may adversely affect the lubricating properties of the engine oil. • NEVER overfill. Overfilling may result in white exhaust smoke, engine overspeed or internal damage.
<small>000005en</small>

CAUTION

<ul style="list-style-type: none"> • ALWAYS be environmentally responsible. • Follow the guidelines of the governmental agencies for the proper disposal of hazardous materials such as engine oil, diesel fuel and engine coolant. Consult the local authorities or reclamation facility. • NEVER dispose of hazardous materials irresponsibly by dumping them into a sewer, on the ground, or into ground water or waterways. • Failure to follow these procedures may seriously harm the environment.
<small>0000013enLN</small>

Check for Engine Oil Leakage

⚠ WARNING



BURN HAZARD!

- NEVER touch hot engine surfaces such as the muffler, exhaust pipe, turbocharger (if equipped) and engine block during operation and shortly after you shut the engine down. These surfaces are extremely hot while the engine is operating and could seriously burn you.
- Failure to comply could result in death or serious injury.

0000015en

Before you operate the engine check for any engine oil leaks.

Check Engine Speed Control

Before you operate the driven machine check the engine speed control. See *Check and Adjust Engine Speed Control* on page 5-32 for adjustment procedure.

1. Check the engine speed control for smooth operation and lubricate or clean as necessary.
2. Check engine speed control for proper adjustments.

Check Spark Arrester (If Equipped)

⚠ WARNING



BURN HAZARD!

- NEVER touch hot engine surfaces such as the muffler, exhaust pipe, turbocharger (if equipped) and engine block during operation and shortly after you shut the engine down. These surfaces are extremely hot while the engine is operating and could seriously burn you.
- Failure to comply could result in death or serious injury.

0000015en

A clogged spark arrester hinders exhaust gas flow which reduces engine output, increases fuel consumption and makes starting difficult. Clean the spark arrester regularly.

Clean the spark arrester (**Figure 5-2, (1)**) as follows:

1. Remove the locknut (**Figure 5-2, (2)**), end cap (**Figure 5-2, (3)**) and diffuser discs (**Figure 5-2, (4)**) from the spark arrester.

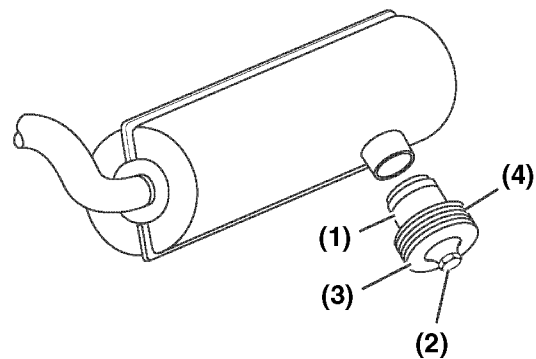

0001567A

Figure 5-2

2. Clean any carbon deposits from the spark arrester.
3. Reinstall the diffuser discs (**Figure 5-2, (4)**) and end cap (**Figure 5-2, (3)**) on the spark arrester (**Figure 5-2, (1)**) and secure with the locknut (**Figure 5-2, (2)**).

Check Fuel Level



<p>FIRE AND EXPLOSION HAZARD!</p> <ul style="list-style-type: none"> • Diesel fuel is flammable and explosive under certain conditions. • ALWAYS fill the fuel tank only with specified diesel fuel. Filling the fuel tank with gasoline may result in a fire and will damage the engine. • NEVER refuel with the engine running. • ALWAYS wipe up all spills immediately. • ALWAYS keep sparks, open flames or any other form of ignition (match, cigarette, static electric source) well away when refueling. • NEVER overfill the fuel tank. • Store any containers containing fuel in a well-ventilated area, away from any combustibles or sources of ignition. • Failure to comply will result in death or serious injury. <p style="text-align: right;">000005en</p>

DANGER



FIRE AND EXPLOSION HAZARD!

- Diesel fuel is flammable and explosive under certain conditions.
- Be sure to place the diesel fuel container on the ground when transferring the diesel fuel from the pump to the container. Hold the hose nozzle firmly against the side of the container while filling. This prevents static electricity buildup which could cause sparks and ignite fuel vapors.
- NEVER place diesel fuel or other flammable material such as oil, hay or dried grass close to the engine during engine operation or shortly after shut down.
- Never inject fuel toward a fire source. Atomized fuel is highly flammable and may cause a fire or burn skin.
- Failure to comply will result in death or serious injury.

0000014enT80

DANGER



FIRE AND EXPLOSION HAZARD!

- Diesel fuel is flammable and explosive under certain conditions.
- ALWAYS check for fuel leaks before you operate the engine. Replace rubberized fuel hoses every two years or every 2000 hours of engine operation, whichever comes first, even if the engine has been out of service. Rubberized fuel lines tend to dry out and become brittle after two years or 2000 hours of engine operation, whichever comes first.
- Failure to comply will result in death or serious injury.

0000015en



CAUTION



- Only use diesel fuels recommended by Yanmar for the best engine performance, to prevent engine damage.
- Only use clean diesel fuel.
- NEVER remove inlet fuel screen from the filler port. If removed, dirt and debris could get into the fuel system causing blockage or damage to the fuel system components.

0000004enLN

Before you operate the engine check the fuel level.
See *Filling the Fuel Tank* on page 4-10.

Check for Fuel Leakage

 WARNING

<p>HIGH-PRESSURE HAZARD!</p> <ul style="list-style-type: none"> • Avoid skin contact with the high-pressure diesel fuel spray caused by a fuel system leak such as a broken fuel injection line. High-pressure fuel can penetrate your skin and result in serious injury. If you are exposed to high-pressure fuel spray, obtain prompt medical treatment. • NEVER check for a fuel leak with your hands. ALWAYS use a piece of wood or cardboard. Have your authorized Yanmar industrial engine dealer or distributor repair the damage. • Failure to comply could result in death or serious injury. <p style="text-align: right;"><small>000008en</small></p>

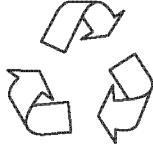
 WARNING

<p>BURN HAZARD!</p> <ul style="list-style-type: none"> • NEVER touch hot engine surfaces such as the muffler, exhaust pipe, turbocharger (if equipped) and engine block during operation and shortly after you shut the engine down. These surfaces are extremely hot while the engine is operating and could seriously burn you. • Failure to comply could result in death or serious injury. <p style="text-align: right;"><small>0000015en</small></p>



CAUTION

<ul style="list-style-type: none"> • ALWAYS be environmentally responsible. • Follow the guidelines of the governmental agencies for the proper disposal of hazardous materials such as engine oil, diesel fuel and engine coolant. Consult the local authorities or reclamation facility. • NEVER dispose of hazardous materials irresponsibly by dumping them into a sewer, on the ground, or into ground water or waterways. • Failure to follow these procedures may seriously harm the environment. <p style="text-align: right;"><small>0000013enLN</small></p>

Before you operate the engine check for any fuel leaks. NEVER use your hands! If you discover a fuel leak see your authorized Yanmar industrial engine dealer or distributor to repair the engine.

Daily, After Operation



- Check for Engine Oil Leakage
- Check for Fuel Leakage

Check for Engine Oil Leakage

 WARNING

<p>BURN HAZARD!</p> <ul style="list-style-type: none">• NEVER touch hot engine surfaces such as the muffler, exhaust pipe, turbocharger (if equipped) and engine block during operation and shortly after you shut the engine down. These surfaces are extremely hot while the engine is operating and could seriously burn you.• Failure to comply could result in death or serious injury.
0000015en

After you shut down the engine check for any engine oil leaks.

Check for Fuel Leakage

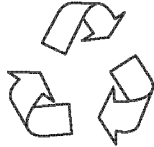
 WARNING

<p>BURN HAZARD!</p> <ul style="list-style-type: none">• NEVER touch hot engine surfaces such as the muffler, exhaust pipe, turbocharger (if equipped) and engine block during operation and shortly after you shut the engine down. These surfaces are extremely hot while the engine is operating and could seriously burn you.• Failure to comply could result in death or serious injury.
0000015en

CAUTION

<ul style="list-style-type: none">• ALWAYS be environmentally responsible.• Follow the guidelines of the governmental agencies for the proper disposal of hazardous materials such as engine oil, diesel fuel and engine coolant. Consult the local authorities or reclamation facility.• NEVER dispose of hazardous materials irresponsibly by dumping them into a sewer, on the ground, or into ground water or waterways.• Failure to follow these procedures may seriously harm the environment.
0000013enLN

⚠ WARNING



HIGH-PRESSURE HAZARD!

- Avoid skin contact with the high-pressure diesel fuel spray caused by a fuel system leak such as a broken fuel injection line. High-pressure fuel can penetrate your skin and result in serious injury. If you are exposed to high-pressure fuel spray, obtain prompt medical treatment.
- NEVER check for a fuel leak with your hands. ALWAYS use a piece of wood or cardboard. Have your authorized Yanmar industrial engine dealer or distributor repair the damage.
- Failure to comply could result in death or serious injury.

000008en

After you shut down the engine check for any fuel leaks. NEVER use your hands! If you discover a fuel leak see your authorized Yanmar industrial engine dealer or distributor to repair the engine.

After Initial 50 Hours of Operation

Perform the following maintenance after the initial 50 hours of operation.

- Replace Engine Oil
- Clean / Inspect Engine Oil Filter

Replace Engine Oil

⚠ WARNING



BURN HAZARD!

- ALWAYS stay clear of the hot engine oil to avoid being burned.
- ALWAYS wear eye protection.
- Failure to comply could result in serious injury.

0000011en

CAUTION

- ALWAYS use only the engine oil specified. Other engine oils may affect warranty coverage, cause internal engine components to seize and / or shorten engine life.
- ALWAYS prevent dirt and debris from contaminating the engine oil. Carefully clean the oil cap / dipstick and the surrounding area before you remove the cap.
- NEVER mix different types of engine oil. This may adversely affect the lubricating properties of the engine oil.
- NEVER overfill. Overfilling may result in white exhaust smoke, engine overspeed or internal damage.

0000005en

CAUTION



- **ALWAYS** be environmentally responsible.
- Follow the guidelines of the governmental agencies for the proper disposal of hazardous materials such as engine oil, diesel fuel and engine coolant. Consult the local authorities or reclamation facility.
- **NEVER** dispose of hazardous materials irresponsibly by dumping them into a sewer, on the ground, or into ground water or waterways.
- Failure to follow these procedures may seriously harm the environment.

0000013enLN

The engine oil on a new engine becomes contaminated from the initial break-in of internal parts. The initial 50 hour oil change and filter cleaning is very important.

Drain the engine oil as follows:

1. Make sure the engine is level.
2. Start the engine and bring it up to operating temperature.
3. Stop the engine.
4. Position a container under the engine to collect waste oil.

5. Remove the drain plug located on the bottom of the cylinder block (**Figure 5-3, (2)**). Allow oil to drain.

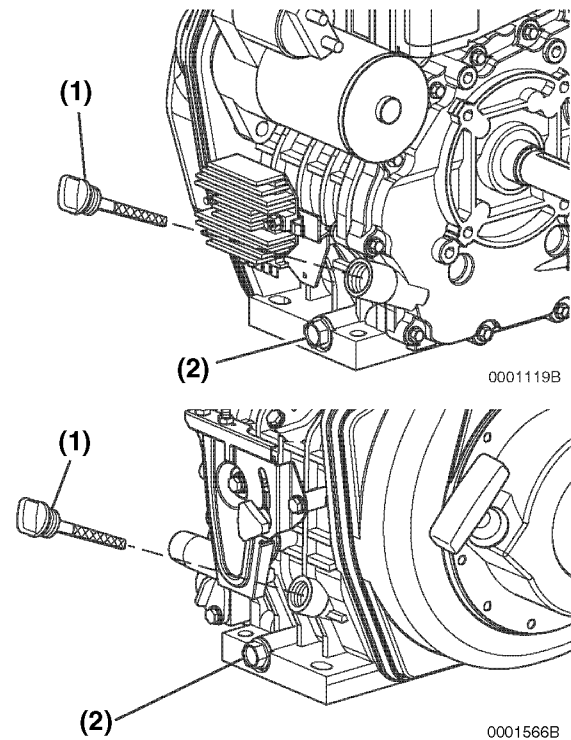

Figure 5-3

6. Remove the oil cap / dipstick (**Figure 5-3, (1)**) to allow the engine oil to drain more easily.
7. After all oil has been drained from the engine, reinstall the drain plug (**Figure 5-3, (2)**) and tighten to 173 - 208 lb-in. (19.6 - 23.5 N·m, 2.0 - 2.4 kgf·m).
8. Dispose of used oil properly.
9. Inspect engine oil filter. See *Clean / Inspect Engine Oil Filter* on page 5-27.

10. Add engine oil (**Figure 5-4, (4)**) as needed until the level is between the upper (**Figure 5-4, (2)**) and lower lines (**Figure 5-4, (3)**) on the oil cap / dipstick (**Figure 5-4, (1)**).

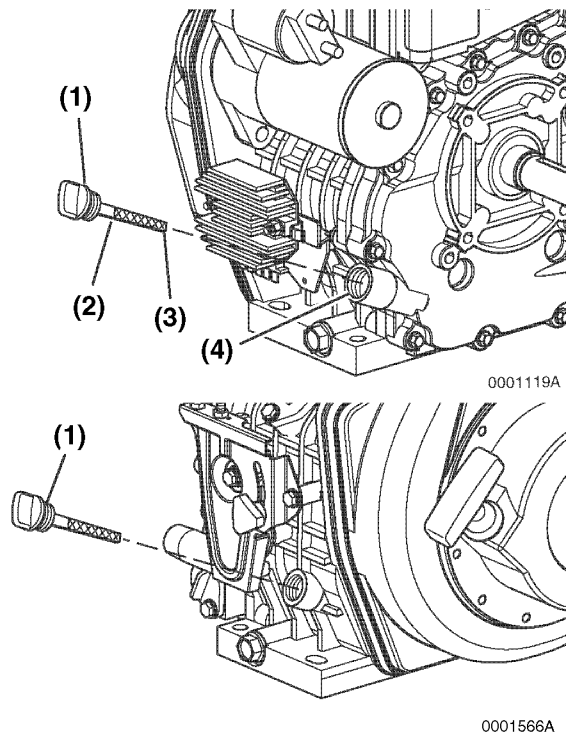

Figure 5-4

11. Add new engine oil to the engine as specified in *Adding Engine Oil on page 4-15*.

CAUTION
<ul style="list-style-type: none"> • NEVER overfill the engine with engine oil. • ALWAYS keep the oil level between the upper and lower lines on the oil cap / dipstick.
000015en

12. Warm up the engine by running it for five minutes and check for any engine oil leaks.
13. After engine is warm, shut it off and let it sit for 10 minutes.
14. Recheck the engine oil level by reinserting the oil cap / dipstick into the crankcase and turn clockwise for one half revolution to engage the first thread in the crankcase opening. See *Checking Engine Oil on page 4-15*.

15. Add oil if necessary.
16. Replace the oil cap / dipstick and tighten by hand. Over-tightening may damage the cap. If any engine oil is spilled, wipe it away with a clean cloth.

Clean / Inspect Engine Oil Filter

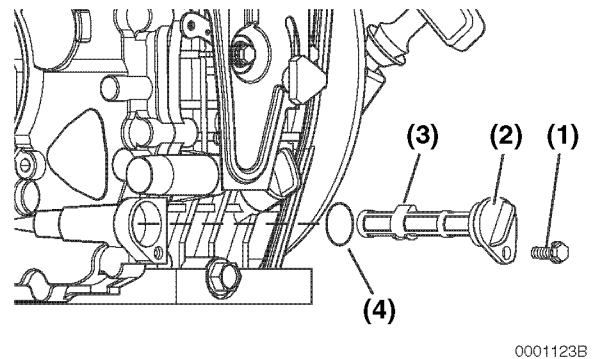

Figure 5-5

Note: It is recommended that this procedure be performed at the same time as the *Replace Engine Oil* procedure.

1. Remove the oil filter retaining bolt (**Figure 5-5, (1)**).
2. Drain engine oil. See *Replace Engine Oil on page 5-25*.
3. Pull the oil filter cap (**Figure 5-5, (2)**) out and remove the oil filter (**Figure 5-5, (3)**).
4. Clean the oil filter in suitable parts cleaner or replace if damaged.
5. Lubricate the O-ring (**Figure 5-5, (4)**) with oil and reinstall the oil filter (**Figure 5-5, (3)**). Replace filter if damaged.

Applicable Engine Oil Filter Part No.	
L48N, L70N and L100N	114250-35070

6. Make sure the oil filter cap is fully seated (**Figure 5-5, (2)**).
7. Reinstall and tighten the oil filter retaining bolt (**Figure 5-5, (1)**).
8. Add new engine oil to the engine as specified in *Adding Engine Oil on page 4-15*.
9. Warm up the engine by running it for five minutes and check for any engine oil leaks.

PERIODIC MAINTENANCE

10. After engine is warm, shut it off and let it sit for 10 minutes.
11. Recheck the engine oil level by reinserting the oil cap / dipstick into the crankcase and turn clockwise for one half revolution to engage the first thread in the crankcase opening. *See Checking Engine Oil on page 4-15.*
12. Replace the oil cap / dipstick (**Figure 5-4, (1)**) and tighten by hand. Over-tightening may damage the cap. If any engine oil is spilled, wipe it away with a clean cloth.

Every 50 Hours of Operation

Perform the following maintenance every 50 hours of operation.

- Clean Inlet Fuel Screen

Clean Inlet Fuel Screen

 **DANGER**



FIRE AND EXPLOSION HAZARD!

- Diesel fuel is flammable and explosive under certain conditions.
- **ALWAYS** put an approved container under any opening to catch the fuel when removing any fuel system component to perform maintenance (such as changing the fuel filter).
- **NEVER** use a shop rag to catch the fuel. Vapors from the rag are flammable and explosive.
- **ALWAYS** wipe up any spills immediately.
- **ALWAYS** wear eye protection. The fuel system is under pressure and fuel could spray out when you remove any fuel system component.
- Failure to comply will result in death or serious injury.

000009en

1. Clean the area around the fuel cap (Figure 5-6, (1)).
2. Remove the fuel cap from the fuel tank (Figure 5-6, (2)).

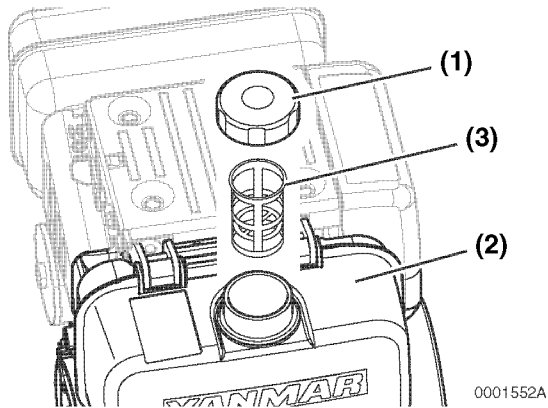

Figure 5-6

3. Lift out the inlet fuel screen (Figure 5-6, (3)).
4. Clean the inlet fuel screen or replace if damaged.
5. Reinstall the inlet fuel screen.
6. Replace the fuel cap and hand-tighten. Over-tightening the fuel cap will damage it.

Inlet Fuel Screen Part No.	
L48N, L70N and L100N	114250-55100

Every 200 Hours of Operation

Perform the following maintenance every 200 hours of operation.

- Clean Air Cleaner Element
- Replace Engine Oil and Clean / Inspect Engine Oil Filter
- Check Engine Speed Control
- Drain the Fuel Tank and Replace Outlet Fuel Filter

Clean Air Cleaner Element

⚠ CAUTION

FLYING OBJECT HAZARD!

- **ALWAYS** wear eye protection when servicing the engine and when using compressed air or high-pressure water. Dust, flying debris, compressed air, pressurized water or steam may injure your eyes.
- Failure to comply may result in minor or moderate injury.

0000003en

CAUTION

- When the engine is operated in dusty conditions, clean the air cleaner element more frequently.
- **NEVER** operate the engine with the air cleaner element(s) removed. This may allow foreign material to enter the engine and damage it.

0000026en

PERIODIC MAINTENANCE

Note: Engine performance is adversely affected when the air cleaner element is clogged with dust. Be sure to clean or replace the air cleaner element periodically.

L48N Models

The L48N model engines use a “wet” type air filter element. The air filter element is sealed inside a metal housing and coated in a light coat of oil to help filter debris. This type of air filter element is **NOT WASHABLE** and should be replaced every 200 hours or earlier if found excessively dirty.

1. Remove the wing nut (**Figure 5-7, (5)**) and gasket (**Figure 5-7, (4)**).
2. Remove the air cleaner cover (**Figure 5-7, (3)**).
3. Remove the air cleaner element (**Figure 5-7, (2)**).
4. Visually inspect the element and determine if replacement is needed. If there is any doubt the element is usable, it should be replaced.
5. Clean the inside and outside of the air cleaner housing and cover (**Figure 5-7, (1, 3)**).
6. Reinstall (or install the new) air cleaner element (**Figure 5-7, (2)**) into the air cleaner housing.
7. Reinstall the air cleaner cover.
8. Reinstall the wing nut and gasket and hand-tighten. Over-tightening the wing nut will damage the air cleaner assembly.

Air Cleaner Element Part No.	
L48N	114250-12581

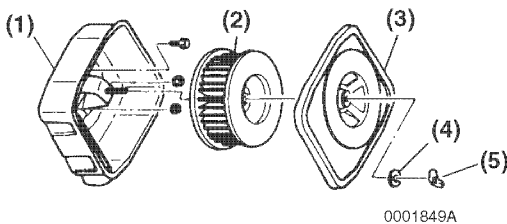

Figure 5-7

L70N and L100N Models

The L70 and L100N model engines use a “dry” type air filter element. The air filter element is an open paper type element. This type of air filter element should be cleaned or replaced every 200 hours or earlier if found excessively dirty.

1. Remove the wing nut (**Figure 5-8, (1)**).
2. Remove the air cleaner cover (**Figure 5-8, (2)**).
3. Remove the wing nut (**Figure 5-8, (3)**).
4. Remove the air cleaner element (**Figure 5-8, (4)**) and outer foam element (**Figure 5-8, (5)**).
5. Blow air through both elements using 42 - 71 psi (0.29 - 0.49 MPa, 3.0 - 5.0 kgf/cm²) compressed air to remove any debris. Blow air from the inside to the outside of the filter element using the lowest possible air pressure to remove dust without damaging the elements.
6. Check the condition of the air filter element by shining a flashlight from the backside of the air filter element. If light is not visible on the outside of the air filter element, replace the air filter element.
7. If either element is damaged, replace both of them. (They are not sold individually.)
8. Clean the inside of the air cleaner cover (**Figure 5-8, (2)**).

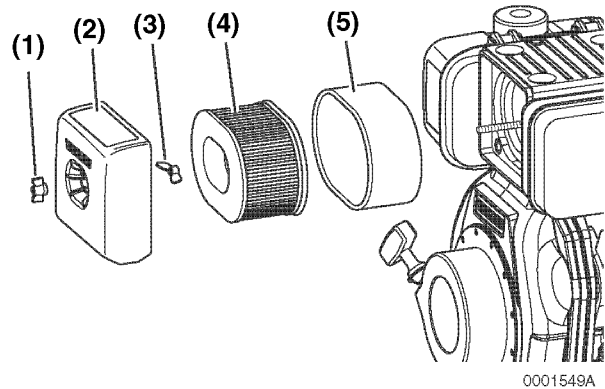

Figure 5-8

9. Reinstall the air cleaner element (**Figure 5-8, (4)**) into the air cleaner housing.

10. Slide the outer foam element (Figure 5-8, (5)) over the air cleaner element (Figure 5-8, (4)).
11. Reinstall the wing nut (Figure 5-8, (3)) and hand-tighten. Over-tightening the wing nut will damage the air cleaner assembly.
12. Reinstall the air cleaner cover (Figure 5-8, (2)).
13. Reinstall the wing nut (Figure 5-8, (1)) and hand-tighten. Over-tightening the wing nut will damage the air cleaner assembly.

Air Cleaner Element Part No.	
L70N and L100N	114210-12590

Replace Engine Oil and Clean / Inspect Engine Oil Filter

CAUTION
<ul style="list-style-type: none"> • ALWAYS use only the engine oil specified. Other engine oils may affect warranty coverage, cause internal engine components to seize and / or shorten engine life. • ALWAYS prevent dirt and debris from contaminating the engine oil. Carefully clean the oil cap / dipstick and the surrounding area before you remove the cap. • NEVER mix different types of engine oil. This may adversely affect the lubricating properties of the engine oil. • NEVER overfill. Overfilling may result in white exhaust smoke, engine overspeed or internal damage.
0000005en

CAUTION

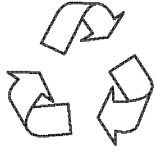

- **ALWAYS** be environmentally responsible.
- Follow the guidelines of the governmental agencies for the proper disposal of hazardous materials such as engine oil, diesel fuel and engine coolant. Consult the local authorities or reclamation facility.
- **NEVER** dispose of hazardous materials irresponsibly by dumping them into a sewer, on the ground, or into ground water or waterways.
- Failure to follow these procedures may seriously harm the environment.

0000013enLN

Change the engine oil every 200 hours of operation after the initial change at 50 hours. Clean and inspect the engine oil filter at the same time. See *Replace Engine Oil on page 5-25 and Clean / Inspect Engine Oil Filter on page 5-27.*

Check and Adjust Engine Speed Control

After you operate the engine for 200 hours, check the engine speed control.

Several types of engine speed controls are used in LN engine applications. This procedure covers a typical example. See *Speed Control Device on page 7-27* for other configurations.

Never force the throttle cable or pedal to move. This may deform the governor lever or stretch the cable and cause irregular operation of the engine speed control.

1. On remote controlled variable speed engines, check that the governor lever (**Figure 5-9, (1)**) makes uniform contact with the high idle (**Figure 5-9, (3)**) and low idle (**Figure 5-9, (2)**) speed limit screws when the engine speed control is in high idle speed or low idle speed position.
2. If the governor lever does not make contact with the high idle or low idle speed limit screw, loosen the jam nuts and adjust the throttle cable adjustment screw (**Figure 5-9, (4)**).

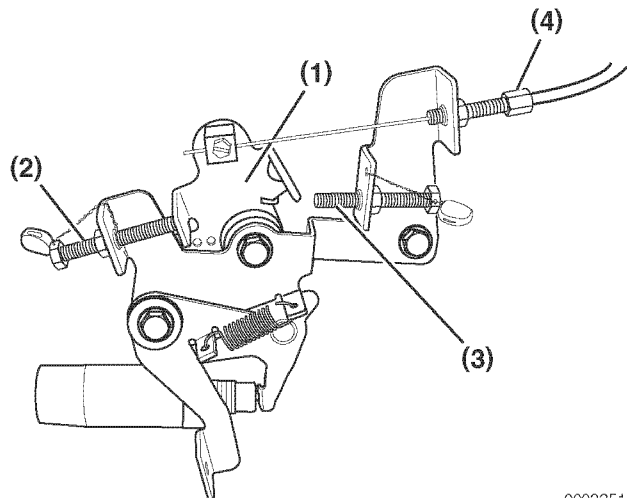

0003251

Figure 5-9

3. On constant speed engines, check that the speed control lever (**Figure 5-10, (1)**) locks into the full speed position when advanced and returns to the stop position when the stop lever (**Figure 5-10, (2)**) is actuated.

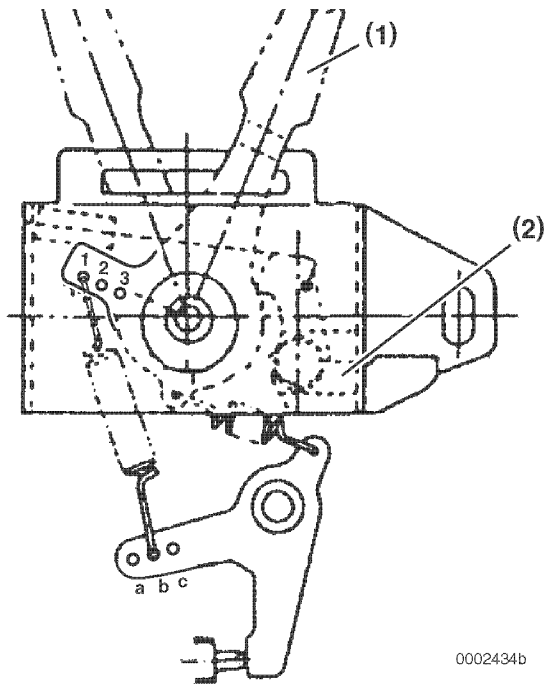

Figure 5-10

Drain the Fuel Tank and Replace Outlet Fuel Filter

⚠ DANGER



FIRE AND EXPLOSION HAZARD!

- Diesel fuel is flammable and explosive under certain conditions.
- **ALWAYS** put an approved container under any opening to catch the fuel when removing any fuel system component to perform maintenance (such as changing the fuel filter).
- **NEVER** use a shop rag to catch the fuel. Vapors from the rag are flammable and explosive.
- **ALWAYS** wipe up any spills immediately.
- **ALWAYS** wear eye protection. The fuel system is under pressure and fuel could spray out when you remove any fuel system component.
- Failure to comply will result in death or serious injury.

000009en

CAUTION

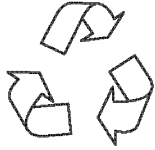

- **ALWAYS** be environmentally responsible.
- Follow the guidelines of the governmental agencies for the proper disposal of hazardous materials such as engine oil, diesel fuel and engine coolant. Consult the local authorities or reclamation facility.
- **NEVER** dispose of hazardous materials irresponsibly by dumping them into a sewer, on the ground, or into ground water or waterways.
- Failure to follow these procedures may seriously harm the environment.

0000013enLN

1. Remove the fuel cap (**Figure 5-11, (1)**).
2. Position an approved container under the fuel tank to collect the fuel and remove the fuel tank drain plug (**Figure 5-11, (2)**) and gasket (**Figure 5-11, (3)**) to drain the fuel.

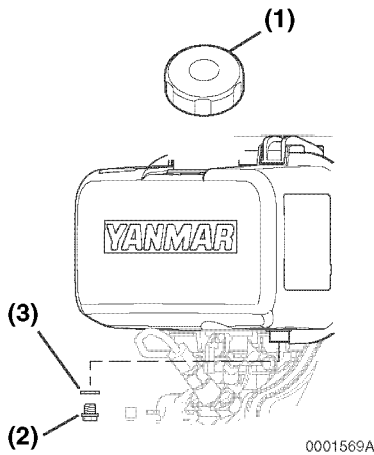
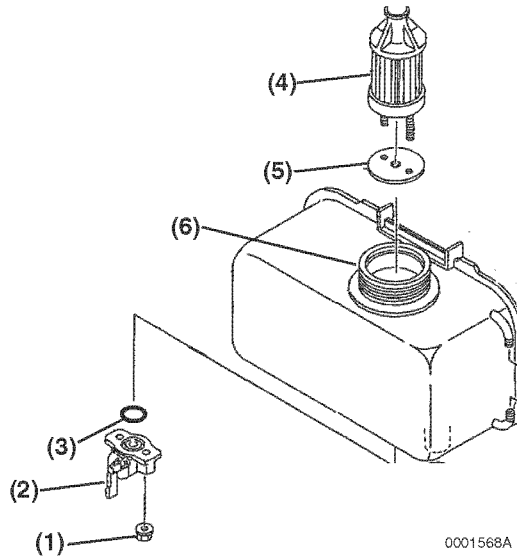

Figure 5-11

3. Loosen the nuts (**Figure 5-12, (1)**) on both sides of fuel shut off valve (**Figure 5-12, (2)**).

4. Remove and discard the O-ring (**Figure 5-12, (3)**).
5. Pull the outlet fuel filter (**Figure 5-12, (4)**) and gasket (**Figure 5-12, (5)**) out of the fuel tank filler port (**Figure 5-12, (6)**).



0001568A

Figure 5-12

6. Install a new outlet fuel filter (**Figure 5-12, (4)**) and gasket (**Figure 5-12, (5)**) through the fuel tank filler port (**Figure 5-12, (6)**) and seat in the fuel tank.

Outlet Fuel Filter Part No.	
L48N, L70N and L100N	114250-55121

O-Ring Part No.	
L48N, L70N and L100N	24341-000150

7. Install a new O-ring (**Figure 5-12, (3)**) on the fuel shut off valve (**Figure 5-12, (2)**) and fasten the assembly to the fuel tank with the fuel shut off valve nuts (**Figure 5-12, (1)**).
8. Tighten the fuel tank drain plug (**Figure 5-11, (2)**) with new gasket (**Figure 5-11, (3)**).
9. Replace the fuel cap (**Figure 5-11, (1)**) and hand-tighten. Over-tightening the fuel cap will damage it. Refill fuel tank. *See Filling the Fuel Tank on page 4-10.*

Every 500 Hours of Operation

Perform the following maintenance every 500 hours of operation.

- Adjust Intake and Exhaust Valve Clearance
- Replace Outlet Fuel Filter
- Inspect and Clean Fuel Injection Nozzle

Adjust Intake and Exhaust Valve Clearance

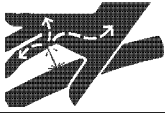

 <p>WARNING</p>

<p>HIGH-PRESSURE HAZARD!</p> <ul style="list-style-type: none"> • Avoid skin contact with the high-pressure diesel fuel spray caused by a fuel system leak such as a broken fuel injection line. High-pressure fuel can penetrate your skin and result in serious injury. If you are exposed to high-pressure fuel spray, obtain prompt medical treatment. • NEVER check for a fuel leak with your hands. ALWAYS use a piece of wood or cardboard. Have your authorized Yanmar industrial engine dealer or distributor repair the damage. • Failure to comply could result in death or serious injury. <p style="text-align: right;">0000008en</p>

Proper adjustment is necessary to maintain the correct timing for opening and closing the valves. Improper adjustment will cause the engine to run noisily, resulting in poor engine performance and engine damage. See *Measuring and Adjusting Valve Clearance* on page 6-39.

Replace Outlet Fuel Filter

To replace the outlet fuel filter. See *Drain the Fuel Tank and Replace Outlet Fuel Filter* on page 5-33.

Inspect, Clean and Test Fuel Injection Nozzle, if required

 <p>WARNING</p>

<p>HIGH-PRESSURE HAZARD!</p> <ul style="list-style-type: none"> • Avoid skin contact with the high-pressure diesel fuel spray caused by a fuel system leak such as a broken fuel injection line. High-pressure fuel can penetrate your skin and result in serious injury. If you are exposed to high-pressure fuel spray, obtain prompt medical treatment. • NEVER check for a fuel leak with your hands. ALWAYS use a piece of wood or cardboard. Have your authorized Yanmar industrial engine dealer or distributor repair the damage. • Failure to comply could result in death or serious injury. <p style="text-align: right;">0000008en</p>

Proper operation of the fuel injectors is required to obtain the optimum injection pattern for full engine performance. See *Testing of Fuel Injector* on page 7-23.

Every 1000 Hours of Operation

Perform the following maintenance every 1000 hours of operation.

- Check Compression

Check Compression

An engine compression check is required every 1000 hours to obtain optimum engine performance. See *Measuring Compression Pressure on page 11-5*.

Every 2000 Hours of Operation

Perform the following maintenance every 2000 hours of operation.

- Check and Replace Fuel Hoses

Check and Replace Fuel Hoses

CAUTION

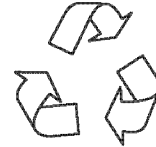

- **ALWAYS** be environmentally responsible.
- Follow the guidelines of the governmental agencies for the proper disposal of hazardous materials such as engine oil, diesel fuel and engine coolant. Consult the local authorities or reclamation facility.
- **NEVER** dispose of hazardous materials irresponsibly by dumping them into a sewer, on the ground, or into ground water or waterways.
- Failure to follow these procedures may seriously harm the environment.

0000013enLN

Regularly check the fuel system hoses. If they are cracked or degraded, replace them. Replace the hoses at least every two years, or 2000 hours, whichever occurs first.

Section 6



ENGINE



	Page
Before You Begin Servicing	6-3
Introduction.....	6-4
Specifications	6-5
Cylinder Head Assembly	6-5
Crankshaft, Balancer Shaft, Piston and Connecting Rod.....	6-8
Camshaft and Tappet.....	6-14
Cylinder Block and Crankcase Cover.....	6-15
Oil Pump (Trochoid Pump)	6-17
Special Torque Specifications	6-18
Special Service Tools.....	6-20
Measuring Instruments.....	6-22
Cylinder Head.....	6-24
Removal of Cylinder Head.....	6-24
Disassembly of Cylinder Head	6-25
Inspection of Cylinder Head Components	6-26
Reassembly of Cylinder Head.....	6-31
Installation of Cylinder Head.....	6-33
Calculating Cylinder Head Gasket Thickness	6-34
Checking Actual Piston TDC (Top Dead Center)	6-36
Measuring and Adjusting Valve Clearance.....	6-39
Engine	6-40
Removal of Engine	6-40
Disassembly of Engine	6-42
Inspection of Engine Components.....	6-45
Reassembly of Engine.....	6-55
Installation of Engine	6-67

This Page Intentionally Left Blank

BEFORE YOU BEGIN SERVICING



Before performing any service procedures within this section, read the following safety information and review the *Safety* section on page 3-1.

 WARNING

ALWAYS wear SAFETY GLASSES while servicing the engine to prevent possible eye injury.
0000013en

 WARNING

ENTANGLEMENT HAZARD!
<ul style="list-style-type: none"> • ALWAYS stop the engine before you begin to service it. • NEVER leave the key in the key switch when you are servicing the engine. Someone may accidentally start the engine and not realize you are servicing it. • Failure to comply could result in death or serious injury.
0000010en

 WARNING

FUME / BURN HAZARD!
<ul style="list-style-type: none"> • ALWAYS read and follow safety related precautions found on containers of hazardous substances like parts cleaners, primers, sealants and sealant removers. • Failure to comply could result in death or serious injury.
0000014en

 CAUTION

FLYING OBJECT HAZARD!
<ul style="list-style-type: none"> • ALWAYS wear eye protection when servicing the engine and when using compressed air or high-pressure water. Dust, flying debris, compressed air, pressurized water or steam may injure your eyes. • Failure to comply may result in minor or moderate injury.
0000003en

CAUTION

- **ALWAYS** use only the engine oil specified. Other engine oils may affect warranty coverage, cause internal engine components to seize and / or shorten engine life.
- **ALWAYS** prevent dirt and debris from contaminating the engine oil. Carefully clean the oil cap / dipstick and the surrounding area before you remove the cap.
- **NEVER** mix different types of engine oil. This may adversely affect the lubricating properties of the engine oil.
- **NEVER** overfill. Overfilling may result in white exhaust smoke, engine overspeed or internal damage.

0000005en

INTRODUCTION

This section of the *Service Manual* describes the disassembly, inspection, and reassembly of the engine.

SPECIFICATIONS

Note: All dimensions given are for standard original components. Oversize pistons and piston rings, as well as undersize bearings, are available and may have been installed some time during the life of the engine. Add the oversize or subtract the undersize from the standard dimension to measure these replacement parts. Refer to the parts catalog for the available sizes.

Cylinder Head Assembly

Valve Clearance

Inspection Item	Standard	Limit	Reference Page
All Models - Intake / Exhaust	0.006 ± 0.002 in. (0.15 ± 0.05 mm)	-	See <i>Measuring and Adjusting Valve Clearance</i> on page 6-39.

Cylinder Head

Inspection Item				Standard	Limit	Reference Page
Combustion Surface Distortion (Flatness)				0.0012 in. (0.03 mm) or less	0.0059 in. (0.15 mm)	See <i>Cylinder Head Distortion</i> on page 6-30.
Valve Recession - All Models				0.016 - 0.032 in. (0.4 - 0.8 mm)	0.039 in. (1.0 mm)	See <i>Valve Recession</i> on page 6-27.
Valve Seat	Width	L48N	Intake / Exhaust	0.1003 in. (2.55 mm)	-	See <i>Valve Face and Valve Seat</i> on page 6-26.
		L70N, L100N	Intake / Exhaust	0.0551 in. (1.4 mm)	-	
	Angle	All	Intake / Exhaust	90°	-	

Intake / Exhaust Valve Seat

Inspection Item			Standard	Limit	Reference Page
Seat Angle - All Models		Intake / Exhaust	90°	-	See <i>Valve Face and Valve Seat</i> on page 6-26.
Seat Width	L48N	Intake / Exhaust	0.100 in. (2.55 mm)	-	
	L70N, L100N	Intake / Exhaust	0.055 in. (1.40 mm)	-	

ENGINE

Intake / Exhaust Valves, Guides and Seals

Inspection item			Standard	Limit	Reference Page
L48N	Intake	Guide Inside Diameter	0.2165 - 0.2171 in. (5.500 - 5.515 mm)	0.220 in. (5.58 mm)	<i>See Valves and Valve Guides on page 6-27 and Reassembly of Intake / Exhaust Valves on page 6-31.</i>
		Valve Stem Outside Diameter	0.1757 - 0.1761 in. (5.465 - 5.475 mm)	0.213 in. (5.40 mm)	
	Exhaust	Guide Inside Diameter	0.2165 - 0.2171 in. (5.500 - 5.515 mm)	0.220 in. (5.58 mm)	
		Valve Stem Outside Diameter	0.1755 - 0.1761 in. (5.460 - 5.475 mm)	0.213 in. (5.40 mm)	
	Seal	Installed Height	0.374 in. (9.5 mm)	-	
L70N	Intake	Guide Inside Diameter	0.2362 - 0.2368 in. (6.000 - 6.015 mm)	0.239 in. (6.08 mm)	
		Valve Stem Outside Diameter	0.2346 - 0.2352 in. (5.960 - 5.975 mm)	0.232 in. (5.90 mm)	
	Exhaust	Guide Inside Diameter	0.2362 - 0.2368 in. (6.000 - 6.015 mm)	0.239 in. (6.08 mm)	
		Valve Stem Outside Diameter	0.2342 - 0.2346 in. (5.950 - 5.960 mm)	0.232 in. (5.90 mm)	
	Seal	Installed Height	0.334 in. (8.5 mm)	-	
L100N	Intake	Guide Inside Diameter	0.2756 - 0.2762 in. (7.000 - 7.015 mm)	0.279 in. (7.08 mm)	
		Valve Stem Outside Diameter	0.2740 - 0.2746 in. (6.960 - 6.975 mm)	0.272 in. (6.90 mm)	
	Exhaust	Guide Inside Diameter	0.2756 - 0.2762 in. (7.000 - 7.015 mm)	0.279 in. (7.08 mm)	
		Valve Stem Outside Diameter	0.2734 - 0.2740 in. (6.945 - 6.96 mm)	0.272 in. (6.90 mm)	
	Seal	Installed Height	0.531 in. (13.5 mm)	-	

Push Rod

Inspection Item		Standard	Limit	Reference Page
Push Rod Length	L48N	5.110 - 5.126 in. (129.8 - 130.2 mm)	-	-
	L70N	6.390 - 6.406 in. (162.3 - 162.7 mm)	-	-
	L100N	7.748 - 7.764 in. (196.8 - 197.2 mm)	-	-
Push Rod Bend	All Models	Less than: 0.002 in. (0.05 mm)	0.012 in. (0.3 mm)	<i>See Push Rod Bend on page 6-29.</i>

Valve Spring

Inspection Item		Standard	Limit	Reference Page
L48N	Free Length	1.102 in. (28.0 mm)	1.043 in. (26.5 mm)	<i>See Valve Springs on page 6-28.</i>
	Inclination	Less than: 0.295 in. (0.75 mm)	-	
	Spring Tension / mm	2.5 - 3.1 lbf (11.2 - 13.7 N, 1.14 - 1.40 kgf)	-	
L70N	Free Length	1.299 in. (33.0 mm)	1.240 in. (31.5 mm)	
	Inclination	Less than: 0.0236 (1.16 mm)	-	
	Spring Tension / mm	2.8 - 3.4 lbf (12.5 - 15.2 N, 1.27 - 1.55 kgf)	-	
L100N	Free Length	1.575 in. (42.0 mm)	1.551 in. (39.5 mm)	
	Inclination	Less than: 0.039 in. (1.0 mm)	-	
	Spring Tension (Measured compressed at minimum of 8 mm.)	4.0 - 5.5 lbf (17.7 - 24.6 N, 1.8 - 2.51 kgf)	-	

Rocker Arm and Shaft

Inspection Item		Standard	Limit	Reference Page
L48N, L70N	Shaft Hole Diameter	0.4730 - 0.4737 in. (12.016 - 12.034 mm)	0.47638 in. (12.10 mm)	<i>See Rocker Arms and Push Rods on page 6-29.</i>
	Shaft Outside Diameter	0.4720 - 0.4724 in. (11.989 - 12.0 mm)	0.4685 in. (11.90 mm)	
L100N	Shaft Hole Diameter	0.5918 - 0.5923 in. (15.032 - 15.045 mm)	0.59449 in. (15.10 mm)	
	Shaft Outside Diameter	0.5901 - 0.5905 in. (15.989 - 15.0 mm)	0.58661 in. (14.90 mm)	

Crankshaft, Balancer Shaft, Piston and Connecting Rod

Crankshaft

Inspection Item			Standard	Limit	Reference Page	
Connecting Rod Journal	L48N	Outside Diameter	1.1797 - 1.1803 in. (29.965 - 29.982 mm)	1.1771 in. (29.90 mm)		
		Oil Clearance	0.0001 - 0.0020 in. (0.004 - 0.053 mm)	-		
	L70N	Outside Diameter	1.4159 - 1.4166 in. (35.965 - 35.982 mm)	1.4133 in. (35.90 mm)		
		Oil Clearance	0.0001 - 0.0020 in. (0.004 - 0.053 mm)	-		
	L100N	Outside Diameter	1.5734 - 1.5740 in. (39.965 - 39.982 mm)	1.5708 in. (39.90 mm)		
		Oil Clearance	0.0007 - 0.0030 in. (0.018 - 0.077 mm)	-		
Main Bearing Journal	L48N	Crankcase Cover End	Journal Outside Diameter	1.1811 - 1.1817 in. (30.002 - 30.015 mm)	1.1776 in. (29.91 mm)	<i>See Crankshaft on page 6-48.</i>
			Oil Clearance	0.001 - 0.002 in. (0.025 - 0.058 mm)	0.0067 in. (0.17 mm)	
		Flywheel End	Journal Outside Diameter	1.1811 - 1.1817 in. (30.002 - 30.015 mm)	-	
			Ball Bearing Inside Diameter	1.1807 - 1.1811 in. (29.990 - 30.000 mm)	-	
			Interference Fit	0.0001 - 0.001 in. (0.002 - 0.025 mm)	-	
		L70N	Crankcase Cover End	Journal Outside Diameter	1.3782 - 1.3787 in. (35.007 - 35.018 mm)	
	Oil Clearance			0.001 - 0.002 in. (0.025 - 0.058 mm)	0.0067 in. (0.17 mm)	
	Flywheel End		Journal Outside Diameter	1.3782 - 1.3787 in. (35.007 - 35.018 mm)	-	
			Ball Bearing Inside Diameter	1.3774 - 1.3779 in. (34.988 - 35.000 mm)	-	
			Interference Fit	0.00028 - 0.0012 in. (0.007 - 0.030 mm)	-	
	L100N		Crankcase Cover End	Journal Outside Diameter	1.575 - 1.5755 in. (40.007 - 40.018 mm)	
		Oil Clearance		0.001 - 0.0022 in. (0.025 - 0.056 mm)	0.0067 in. (0.17 mm)	
		Flywheel End	Journal Outside Diameter	1.575 - 1.5755 in. (40.007 - 40.018 mm)	-	
			Ball Bearing Inside Diameter	1.5743 - 1.5747 in. (39.988 - 40.000 mm)	-	
			Interference Fit	0.00028 - 0.0012 in. (0.007 - 0.030 mm)	-	

Balancer Shaft

Inspection Item		Standard	Limit	Reference Page	
Cylinder Block	L48N	Balancer Shaft Diameter	0.5899 - 0.5903 in. (14.983 - 14.994 mm)	-	<i>See Balancer Shaft on page 6-51.</i>
		Cylinder Block Bore Diameter	1.3756-1.3766 in. (34.941-34.966 mm)	-	
		Ball Bearing Inside Diameter	0.5902-0.5906 in. (14.992-15.000 mm)	-	
		Ball Bearing Outside Diameter	1.3775 - 1.3780 in. (34.989-35.000 mm)	-	
		Radial Clearance of Ball Bearing	0.00043 - 0.00098 in. (0.011 - 0.025 mm)	0.0016 in. (0.040 mm)	
Crankcase Cover	Same as Cylinder Block				
Cylinder Block	L70N	Balancer Shaft Diameter	0.6686 - 0.6691 in. (16.983 - 16.994 mm)	-	<i>See Balancer Shaft on page 6-51.</i>
		Cylinder Block Bore Diameter	1.5725 - 1.5735 in. (39.941 - 39.966 mm)	-	
		Ball Bearing Inside Diameter	0.6690 - 0.6693 in. (16.992 - 17.000 mm)	-	
		Ball Bearing Outside Diameter	1.5744 - 1.5748 in. (39.989 - 40.000 mm)	-	
		Radial Clearance of Ball Bearing	0.00043 - 0.00098 in. (0.011 - 0.025 mm)	0.0016 in. (0.040 mm)	
Crankcase Cover	Same as Cylinder Block				
Cylinder Block	L100N	Balancer Shaft Diameter	0.7867 - 0.7872 in. (19.983 - 19.994 mm)	-	<i>See Balancer Shaft on page 6-51.</i>
		Cylinder Block Bore Diameter	2.0449 - 2.0459 in. (51.941 - 51.966 mm)	-	
		Ball Bearing Inside Diameter	0.7870 - 0.7874 in. (19.990 - 20.000 mm)	-	
		Ball Bearing Outside Diameter	2.0467 - 2.0472 in. (51.987 - 52.000 mm)	-	
		Radial Clearance of Ball Bearing	0.00051 - 0.00110 in. (0.013 - 0.028 mm)	0.0016 in. (0.040 mm)	
Crankcase Cover	Same as Cylinder Block				

ENGINE

Piston

Inspection Item		Standard	Limit	Reference Page	
Piston Outside Diameter (Measure 90° to the wrist pin.)	L48N	2.7545 in. (69.965 mm)	2.7441 in. (69.700 mm)	<i>See Piston, Piston Rings and Wrist Pin on page 6-45.</i>	
	L70N	3.0695 in. (77.965 mm)	3.0591 in. (77.700 mm)		
	L100N	3.3841 in. (85.955 mm)	3.3740 in. (85.700 mm)		
Piston Diameter Measurement Location (Upward from the bottom of the piston)	All Models	0.689 in (17.5 mm)			
Clearance Between Piston and Sleeve	L48N, L70N	0.0016 - 0.0024 in. (0.040 - 0.060 mm)	-		
	L100N	0.0020 - 0.0028 in. (0.050 - 0.070 mm)	-		
Wrist Pin	L48N	Hole Inside Diameter	0.7474 - 0.7478 in. (18.985 - 18.996 mm)		0.7508 in. (19.07 mm)
		Pin Outside Diameter	0.7476 - 0.7480 in. (18.991 - 19.0 mm)		0.7448 in. (18.920 mm)
		Oil Clearance	0.0002 - 0.0006 in. (0.005 - 0.015 mm)		-
	L70N	Hole Inside Diameter	0.8261 - 0.8266 in. (20.983 - 20.996 mm)		0.8295 in. (21.07 mm)
		Pin Outside Diameter	0.8264 - 0.8267 in. (20.991 - 21.000 mm)	0.8232 in. (20.91 mm)	
		Oil Clearance	0.0002 - 0.00067 in. (0.005 - 0.017 mm)	-	
	L100N	Hole Inside Diameter	0.9048 - 0.9053 in. (22.983 - 22.996 mm)	0.90830 in. (23.07 mm)	
		Pin Outside Diameter	0.9051 - 0.9055 in. (22.991 - 23.000 mm)	0.9020 in. (22.91 mm)	
		Oil Clearance	0.0002 - 0.00067 in. (0.005 - 0.017 mm)	-	

Piston Ring

Inspection Item			Standard	Limit	Reference Page
L48N	Top Ring	Thickness	0.0578 - 0.05846 in. (1.470 - 1.485 mm)	0.0535 in. (1.36 mm)	<i>See Piston, Piston Rings and Wrist Pin on page 6-45.</i>
		Side Clearance	0.00255 - 0.00374 in. (0.065 - 0.095 mm)	0.0059 in. (0.15 mm)	
		End Gap	0.00787 - 0.01377 in. (0.200 - 0.350 mm)	0.0394 in. (1.00 mm)	
	Second Ring	Thickness	0.0578 - 0.0586 in. (1.470 - 1.490 mm)	0.0535 in. (1.36 mm)	
		Side Clearance	0.00118 - 0.00255 in. (0.030 - 0.065 mm)	0.0059 in. (0.15 mm)	
		End Gap	0.01181 - 0.01771 in. (0.300 - 0.450 mm)	0.0394 in. (1.00 mm)	
	Oil Ring	Thickness	0.1366 - 0.1374 in. (3.470 - 3.490 mm)	0.1322 in. (3.36 mm)	
		Side Clearance	0.00078 - 0.0026 in. (0.020 - 0.055 mm)	0.0059 in. (0.15 mm)	
		End Gap	0.0059 - 0.01377 in. (0.150 - 0.350 mm)	0.0394 in. (1.00 mm)	
L70N	Top Ring	Thickness	0.0578 - 0.0585 in. (1.470 - 1.485 mm)	0.0535 in. (1.36 mm)	
		Side Clearance	0.0025 - 0.0037 in. (0.065 - 0.095 mm)	0.0059 in. (0.15 mm)	
		End Gap	0.0079 - 0.0138 in. (0.200 - 0.350 mm)	0.0393 in. (1.0 mm)	
	Second Ring	Thickness	0.0578 - 0.0586 in. (1.470 - 1.490 mm)	0.0535 in. (1.36 mm)	
		Side Clearance	0.0012 - 0.0026 in. (0.030 - 0.065 mm)	0.0059 in. (0.15 mm)	
		End Gap	0.0118 - 0.0177 in. (0.300 - 0.450 mm)	0.0394 in. (1.0 mm)	
	Oil Ring	Thickness	0.1366 - 0.1374 in. (3.470 - 3.490 mm)	0.1322 (3.36 mm)	
		Side Clearance	0.0008 - 0.0026 in. (0.020 - 0.055 mm)	0.0059 in. (0.15 mm)	
		End Gap	0.0059 - 0.0138 in. (0.150 - 0.350 mm)	0.0394 in. (1.0 mm)	

ENGINE

Inspection Item			Standard	Limit	Reference Page
L100N	Top Ring	Thickness	0.0775 - 0.0781 in. (1.970 - 1.985 mm)	0.0732 in. (1.86 mm)	<i>See Piston, Piston Rings and Wrist Pin on page 6-45.</i>
		Side Clearance	0.0026 - 0.0037 in. (0.065 - 0.095 mm)	0.0059 in. (0.15 mm)	
		End Gap	0.0079 - 0.0138 in. (0.200 - 0.350 mm)	0.0394 in. (1.0 mm)	
	Second Ring	Thickness	0.0775 - 0.0783 in. (1.970 - 1.990 mm)	0.0732 in. (1.86 mm)	
		Side Clearance	0.0012 - 0.0026 in. (0.030 - 0.065 mm)	0.0059 in. (0.15 mm)	
		End Gap	0.0118 - 0.0177 in. (0.300 - 0.450 mm)	0.0394 in. (1.0 mm)	
	Oil Ring	Thickness	0.1562 - 0.1570 in. (3.970 - 3.990 mm)	0.1519 in. (3.86 mm)	
		Side Clearance	0.0008 - 0.0026 in. (0.020 - 0.055 mm)	0.0059 in. (0.15 mm)	
		End Gap	0.0059 - 0.0138 in. (0.150 - 0.350 mm)	0.0394 in. (1.0 mm)	

Connecting Rod

Inspection Item			Standard	Limit	Reference Page
L48N	Big End (Crankshaft)	Inside Diameter See Figure 6-1 (1)	1.1816 - 1.1818 in. (29.986 - 30.018 mm)	1.1846 in. (30.09 mm)	See Connecting Rod on page 6-47.
		Oil Clearance	0.00015 - 0.002 in. (0.004 - 0.053 mm)	-	
	Small End (Wrist Pin Bushing)	Inside Diameter See Figure 6-1 (2)	0.7490 - 0.7495 in. (19.025 - 19.038 mm)	0.7519 in. (19.10 mm)	
		Oil Clearance	0.0008 - 0.0020 in. (0.021 - 0.053 mm)	-	
L70N	Big End (Crankshaft)	Inside Diameter See Figure 6-1 (1)	1.4178 - 1.4180 in. (35.986 - 36.018 mm)	1.4208 in. (36.09 mm)	
		Oil Clearance	0.00015 - 0.002 in. (0.004 - 0.053 mm)	-	
	Small End (Wrist Pin Bushing)	Inside Diameter See Figure 6-1 (2)	0.8277 - 0.8282 in. (21.025 - 21.038 mm)	0.8307 in. (21.10 mm)	
		Oil Clearance	0.0008 - 0.0021 in. (0.021 - 0.055 mm)	-	
L100N	Big End (Crankshaft)	Inside Diameter See Figure 6-1 (1)	1.5748 - 1.5764 in. (40.0 - 40.042 mm)	1.5779 in. (40.08 mm)	
		Oil Clearance	0.0007 - 0.0030 in. (0.018 - 0.077 mm)	-	
	Small End (Wrist Pin Bushing)	Inside Diameter See Figure 6-1 (2)	0.9064 - 0.9070 in. (23.025 - 23.038 mm)	0.9094 in. (23.10 mm)	
		Oil Clearance	0.0008 - 0.0021 in. (0.021 - 0.055 mm)	-	

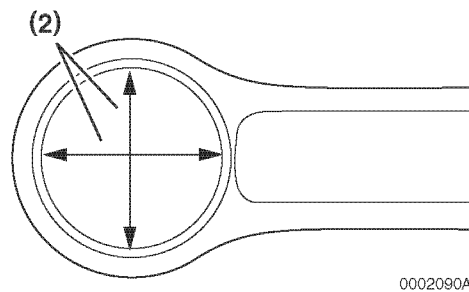
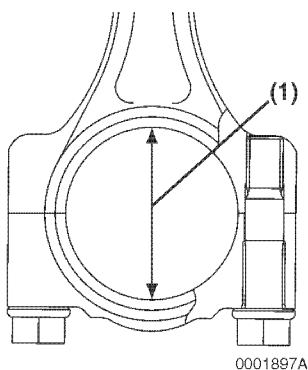

Figure 6-1

ENGINE

Camshaft and Tappet

Camshaft

Inspection Item		Standard	Limit	Reference Page	
End Play - All Models		0.002 - 0.011 in. (0.040 - 0.280 mm)	0.018 in. (0.45 mm)	<i>See Camshaft and Tappet on page 6-50.</i>	
Cylinder Block - All Models	Camshaft Journal Outside Diameter	0.5905 - 0.5909 in. (4.989 - 15.000 mm)	0.5874 in. (14.920 mm)		
	Needle Bearing Inside Diameter	0.5911 - 0.5918 in. (15.016 - 15.034 mm)	-		
	Oil Clearance	0.0006 - 0.0017 in. (0.016 - 0.045 mm)	-		
Crankcase Cover	L48N	Camshaft Journal Outside Diameter	0.9834 - 0.9839 in. (24.980 - 24.993 mm)		0.9803 in. (24.900 mm)
		Bearing Inside Diameter	0.985 - 0.9858 in. (25.020 - 25.041 mm)		-
		Oil Clearance	0.0010 - 0.0024 in. (0.027 - 0.061 mm)		-
	L70N	Camshaft Journal Outside Diameter	1.1803 - 1.1808 in. (29.980 - 29.993 mm)		1.1771 in. (29.900 mm)
		Bearing Inside Diameter	1.1818 - 1.1827 in. (30.020 - 30.041 mm)		-
		Oil Clearance	0.0010 - 0.0024 in. (0.027 - 0.061 mm)		-
	L100N	Camshaft Journal Outside Diameter	1.3771 - 1.3776 in. (34.980 - 34.993 mm)		1.374 in. (34.900 mm)
		Bearing Inside Diameter	1.3787 - 1.3795 in. (35.020 - 35.041 mm)		-
		Oil Clearance	0.0010 - 0.0024 in. (0.027 - 0.061 mm)		-

Tappet

Inspection Item		Standard	Limit	Reference Page
Valves - All Models	Tappet Hole (Block) Inside Diameter	0.2755 - 0.2761 in. (7.000 - 7.015 mm)	0.2779 in. (7.06 mm)	<i>See Camshaft and Tappet on page 6-50.</i>
	Tappet Stem Outside Diameter	0.2740 - 0.2755 in. (6.960 - 6.980 mm)	0.2704 in. (6.87 mm)	
	Oil Clearance	0.0007 - 0.0021 in. (0.020 - 0.055 mm)	-	
Fuel Injection Pump - All Models	Tappet Hole (Block) Inside Diameter	0.9448 - 0.9461 in. (24.000 - 24.033 mm)	0.9472 in. (24.06 mm)	
	Tappet Stem Outside Diameter	0.9831 - 0.9446 in. (23.972 - 23.993 mm)	0.9405 in. (23.89 mm)	
	Oil Clearance	0.00027 - 0.0024 in. (0.007 - 0.061 mm)	-	

Cylinder Block and Crankcase Cover

Cylinder Block

Inspection Item		Standard	Limit	Reference Page	
Crankshaft Ball Bearing	L48N	Housing Bore Inside Diameter	2.8343 - 2.8349 in. (71.9905 - 72.0095 mm)	-	See Crankshaft on page 6-48.
		Ball Bearing Outside Diameter	2.8341 - 2.8346 in. (71.987 - 72.0 mm)	-	
		Interference Fit	0.0003 - 0.0008 in. (0.0095 - 0.0225 mm)	-	
	L70N	Housing Bore Inside Diameter	3.1488 - 3.1494 in. (79.98 - 79.996 mm)	-	
		Ball Bearing Outside Diameter	3.1490 - 3.1496 in. (79.987 - 80.0 mm)	-	
		Interference Fit	0.0003 - 0.0007 in. (0.009 - 0.020 mm)	-	
	L100N	Housing Bore Inside Diameter	3.5426 - 3.5433 in. (89.984 - 90.0 mm)	-	
		Ball Bearing Outside Diameter	3.5427 - 3.5433 in. (89.985 - 90.0 mm)	-	
		Interference Fit	0.0005 - 0.0006 in. (0.015 - 0.016 mm)	-	
Camshaft Needle Bearing Bore - All Models	Inside Diameter	0.8250 - 0.8259 in. (20.957 - 20.978 mm)	-	See Camshaft and Tappet on page 6-50.	
Cylinder Bore Inside Diameter	L48N	2.7559 - 2.7571 in. (70.000 - 70.030 mm)	2.7622 in. (70.16 mm)	See Cylinder Bore on page 6-51.	
	L70N	3.0709 - 3.0720 in. (78.000 - 78.030 mm)	3.0779 in. (78.18 mm)		
	L100N	3.3858 - 3.3870 in. (86.000 - 86.030 mm)	-		

ENGINE

Crankcase Cover

Inspection Item		Standard	Limit	Reference Page	
Crankshaft Sleeve Bearing	L48N	Bore Diameter in Cover	1.3385 - 1.3395 in. (34.000 - 34.025 mm)	-	<i>See Bearings on page 6-49.</i>
		Bearing Outside Diameter	1.3413 - 1.3427 in. (34.070 - 34.105 mm)	-	
		Interference Fit	0.0017 - 0.0041 in. (0.045 - 0.105 mm)	-	
		Bearing Metal Inside Diameter	1.1826 - 1.1834 in. (30.040 - 30.060 mm)	1.1862 in. (30.130 mm)	
	L70N	Bore Diameter in Cover	1.5354 - 1.5364 in. (39.000 - 39.025 mm)	-	
		Bearing Outside Diameter	1.5381 - 1.5395 in. (39.070 - 39.105 mm)	-	
		Interference Fit	0.0017 - 0.0041 in. (0.045 - 0.105 mm)	-	
		Bearing Metal Inside Diameter	1.3796 - 1.3804 in. (35.043 - 35.063 mm)	1.383 in. (35.130 mm)	
	L100N	Bore Diameter in Cover	1.7322 - 1.7332 in. (44.000 - 44.025 mm)	-	
		Bearing Outside Diameter	1.7356 - 1.737 in. (44.085 - 44.120 mm)	-	
		Interference Fit	0.0023 - 0.0047 in. (0.060 - 0.120 mm)	-	
		Bearing Metal Inside Diameter	1.5764 - 1.5772 in. (40.043 - 40.063 mm)	1.5799 in. (40.130 mm)	
Camshaft Ball Bearing	L48N	Bore Diameter in Cover	2.045 - 2.0458 in. (51.945 - 51.965 mm)	-	<i>See Camshaft and Tappet on page 6-50.</i>
		Ball Bearing Outside Diameter	2.0467 - 2.0472 in. (51.987 - 52.000 mm)	-	
		Interference Fit	0.0008 - 0.0021 in. (0.022 - 0.055 mm)	-	
	L70N	Bore Diameter in Cover	2.4385 - 2.4393 in. (61.940 - 61.960 mm)	-	
		Ball Bearing Outside Diameter	2.4404 - 2.4409 in. (61.987 - 62.000 mm)	-	
		Interference Fit	0.001 - 0.0023 in. (0.027 - 0.060 mm)	-	
	L100N	Bore Diameter in Cover	2.832 - 2.8328 in. (71.935 - 71.955 mm)	-	
		Ball Bearing Outside Diameter	2.8341 - 2.8346 in. (71.987 - 72.000 mm)	-	
		Interference Fit	0.0012 - 0.0025 in. (0.032 - 0.065 mm)	-	

Oil Pump (Trochoid Pump)

Inspection Item		Standard	Limit	Reference Page
All Models	Outer Rotor Outside Diameter	1.1401 - 1.1409 in. (28.960 - 28.980 mm)	1.1377 in. (28.900 mm)	See <i>Installation of Crankcase Cover on page 6-65.</i>
	Oil Pump Cavity Diameter (Crankcase Cover)	1.1456 - 1.1464 in. (29.100 - 29.121 mm)	1.1488 in. (29.180 mm)	
	Outer Rotor-to-Crankcase Cover Bore Clearance	0.0047 - 0.0063 in. (0.120 - 0.161 mm)	-	
	Outer and Inner Rotor Width	0.3137 - 0.3149 in. (7.970 - 8.000 mm)	0.3110 in. (7.900 mm)	
	Oil Pump Cavity Depth (Crankcase Cover)	0.3157 - 0.3169 in. (8.020 - 8.050 mm)	0.3188 in. (8.100 mm)	
	Rotor Recess	0.0007 - 0.0031 in. (0.020 - 0.080 mm)	-	
	Inner Rotor-to-Outer Rotor Clearance	0.0000 - 0.0055 in. (0.000 - 0.140 mm)	0.0098 in. (0.25 mm)	

Special Torque Specifications

Component	Model	Thread Diameter and Pitch	Torque	Lubricating Oil Application (Thread Portion and Seat Surface)
Crankcase Cover Bolt	L48N	14-M6 x 1.0 mm	96 - 114 lb-in. (10.8 - 12.8 N·m, 1.1 - 1.3 kgf·m)	Not Applied
	L70N, L100N	13-M8 x 1.25 mm	225 - 243 lb-in. (25.5 - 27.5 N·m, 2.6 - 2.8 kgf·m)	
Stiffener Bolts on Crankcase Cover	All Models	M8 x 1.25 mm	225 - 242 lb-in. (25.5 - 27.4 N·m, 2.6 - 2.8 kgf·m)	Not Applied
Connecting Rod Nuts and Bolts	L48N, L70N	2-M7 x 1.0 mm	200 - 243 lb-in. (22.6 - 27.5 N·m, 2.3 - 2.8 kgf·m)	Applied
	L100N	2-M8 x 1.0 mm	32.5 - 36 lb-ft (44.1 - 49.0 N·m, 4.9 - 5.0 kgf·m)	
Flywheel Nut	L48N	M16 x 1.5 mm	101.5 - 108.7 lb-ft (137.3 - 147.1 N·m, 14.0 - 15.0 kgf·m)	Applied
	L70N	M16 x 1.5 mm	116 - 123.2 lb-ft (156.9 - 166.7 N·m, 16.0 - 17.0 kgf·m)	
	L100N	M18 x 1.5 mm	159 - 166 lb-ft (215.7 - 225.6 N·m, 22.0 - 23.0 kgf·m)	
Cylinder Head Nuts (Final Torque)	L48N	M8 x 1.25 mm	21.5 - 24.4 lb-ft (29.4 - 33.3 N·m, 3.0 - 3.4 kgf·m)	Applied
	L70N	M9 x 1.5 mm	34.8 - 37.8 lb-ft (47 - 51 N·m, 4.8 - 5.2 kgf·m)	
	L100N	M10 x 1.25 mm	44.0 - 46.9 lb-ft (59.8 - 63.7 N·m, 6.1 - 6.5 kgf·m)	
Valve Rocker Arm Support	L48N, L70N	M6 x 1.00 mm	88 - 106 lb-in. (10 - 12 N·m, 1.0 - 1.2 kgf·m)	Not Applied
	L100N	M8 x 1.5 mm	225 - 243 lb-in. (25.5 - 27.5 N·m, 2.6 - 2.8 kgf·m)	Not Applied

Component	Model	Thread Diameter and Pitch	Torque	Lubricating Oil Application (Thread Portion and Seat Surface)
Fuel Nozzle Case Nut	All Models	U-0.605-40UNS-2B	30 - 35 lb-ft (40.7 - 47.5 N·m, 4.2 - 4.8 kgf·m)	Not Applied
Fuel Pump Delivery Valve (If Equipped)		M14 x 15 mm	21.5 - 25 lb-ft (29.4 - 34.3 N·m, 3.0 - 3.5 kgf·m)	Not Applied
Fuel Injection Pump Nuts		3-M6 x 1.0 mm	87 - 104 lb-in. (9.8 - 11.8 N·m, 1.0 - 1.2 kgf·m)	Not Applied
Fuel Injection Nozzle Nuts		2-M6 x 1.0 mm	61.3 - 79 lb-in. (6.9 - 8.9 N·m, 0.7 - 0.9 kgf·m)	Not Applied
Fuel Injection Pump Inspection Window Plate Nuts		3-M6x1.0 mm	87 - 104 lb-in. (9.8 - 11.8 N·m, 1.0 - 1.2 kgf·m)	Not Applied
Fuel Limiter Mounting Nut		-	215 - 218 lb-in. (24.2 - 24.6 N·m, 2.4 - 2.5 kgf·m)	Not Applied
High Pressure Fuel Injection Line Nuts		-	19.8 - 23.5 lb-ft (26.9 - 31.9 N·m, 2.7 - 3.3 kgf·m)	Not Applied

See *Tightening Torques for Standard Bolts and Nuts* on page 4-18 for standard hardware torque values.

ENGINE

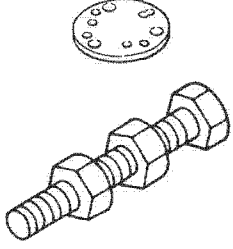
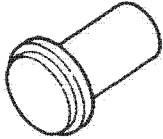
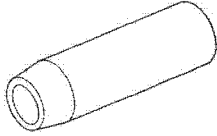
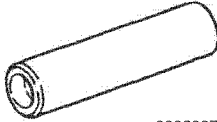
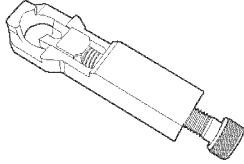

SPECIAL SERVICE TOOLS

No.	Tool Name	Applicable Model and Tool Size					Illustration
1	Flywheel Holder Wrench (For Removing and Installing the Flywheel)	Yanmar Part No. 114250-92101					 0002393
2	Flywheel Puller (For Removing the Flywheel)	Yanmar Part No. 114250-92121					 0002394
		Model	Bolt	Qty. Used	Nut	Qty. Used	
		L48N, L70N	26116-060454	3	26716-060002	6	
L100N	4	8					
3	Oil Seal Installer (For Installing the Crankshaft and Camshaft Oil Seals)	Model	Cylinder Block (Crankshaft) - Yanmar Part No.	Crankcase Cover (Crankshaft and Camshaft) - Yanmar Part No.		 0002395	
		L48N	114350-92311	114250-92311			
		L70N	114350-92311	114350-92311			
		L100N	014650-92311	014650-92311			
4	Oil Seal Protector (For Installing the Crankcase Cover)	Model	Yanmar Part No.			 0002396	
		L48N	114350-92301 or 114268-92300				
		L70N	114268-92300				
		L100N	114268-92300				
5	Valve Stem Seal Installer (For Installing Valve Stem Seals to the Correct Height)	Model	Yanmar Part No.			 0002397	
		L48N	114250-92350				
		L70N	114350-92350				
		L100N	114650-92350				
6	Throttle Shaft Pin Removal Tool (L70N and L100N Models)	Yanmar Part No. 114310-92000					 0004243

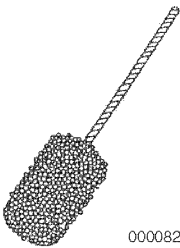
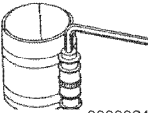
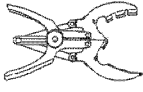
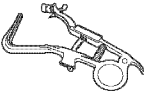
Special Service Tools (Continued)

No.	Tool Name	Applicable Model and Tool Size			Illustration
		Model	Part No.	Cylinder Bore	
7	Flex-Hone (For Honing of Cylinder Bore)	L48N	129400-92400	3.071 - 3.307 in. (70 - 84 mm)	 0000823
		L70N	129400-92420	3.071 - 3.307 in. (78 - 84 mm)	
		L100N	129400-92430	3.268 - 3.740 in. (86 - 95 mm)	
8	Piston Ring Compressor (For Installing Piston)	Yanmar Part No. 95550-002476 The piston ring compressor is applicable for 2.362 - 4.921 in. (60 - 125 mm) diameter pistons			 0000824
9	Piston Ring Expander (For Removal/ Installation of Piston Rings)	Available Locally			 0000825
10	Piston Ring Groove Cleaning Tool	Available Locally			 0002897

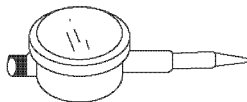
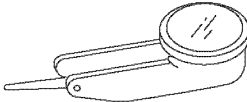
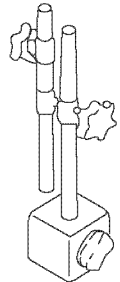
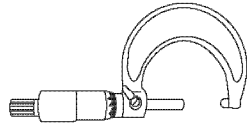
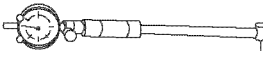
MEASURING INSTRUMENTS

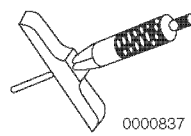
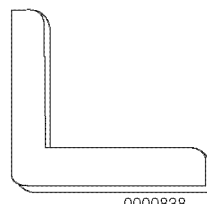
No.	Instrument Name	Application	Illustration
1	Dial Indicator (Available Locally)	Measurements of shaft bending, and strain and gap of surfaces	 <p>0000831</p>
2	Test Indicator (Available Locally)	Measurements of narrow or deep portions that cannot be measured by dial gauge	 <p>0000832</p>
3	Magnetic Stand (Available Locally)	For holding the dial gauge when measuring	 <p>0000833</p>
4	Micrometer (Available Locally)	For measuring the outside diameters of crankshaft, piston, piston pins, etc.	 <p>0000834</p>
5	Cylinder Bore Gauge (Available Locally)	For measuring the inside diameters of cylinder liners, rod metal, etc.	 <p>0000835</p>
6	Calipers (Available Locally)	For measuring outside diameters, depth, thickness and width	 <p>0000836</p>
7	Depth Micrometer (Available Locally)	For measuring amount of valve sink	 <p>0000837</p>
8	Square (Available Locally)	For measuring valve spring inclination and straightness of parts	 <p>0000838</p>

Measuring Instruments (Continued)

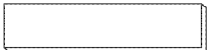
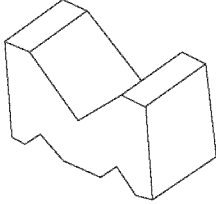
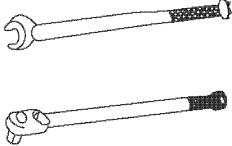
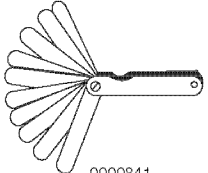
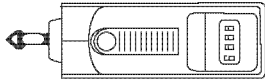
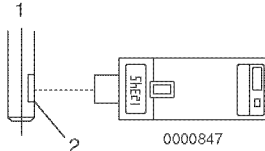
No.	Instrument Name		Application	Illustration
9	Straight Edge (Available Locally)		For measuring cylinder head distortion and straightness of parts	 <p>0003594</p>
10	V-Block (Available Locally)		For measuring shaft bend	 <p>0000839</p>
11	Torque Wrench (Available Locally)		For tightening nuts and bolts to the specified torque	 <p>0000840</p>
12	Feeler Gauge (Available Locally)		For measuring gaps between ring and ring groove, valve clearance and shaft joints during assembly	 <p>0000841</p>
13	Tachometer (Available Locally)	Contact Type	For measuring revolution by contacting the mortise in the revolving shaft	 <p>0000846</p>
		Photoelectric Type	For measuring revolution by sensing the reflecting mark on the outer periphery of the revolving shaft 1 — Revolving Shaft 2 — Reflection Mark	 <p>0000847</p>

CYLINDER HEAD

Removal of Cylinder Head

L48N Models

1. Remove the air cleaner assembly.
2. Remove the fuel tank and fuel tank support brackets.
3. Remove the muffler assembly.

L70N and L100N Models

1. Remove the cylinder head upper cooling cover.
2. Remove the cylinder head side cooling cover.
1. Remove the air cleaner assembly.
2. Remove the fuel tank and fuel tank support brackets.
3. Remove the muffler assembly.

All Models

1. Disconnect the external compression release linkage (if equipped) from the rocker arm cover.
2. Remove the rocker arm (valve) cover.
3. Remove the rocker arm shaft assembly **Figure 6-2**, by first removing the two bolts that secure the rocker arm shaft assembly to the cylinder head.

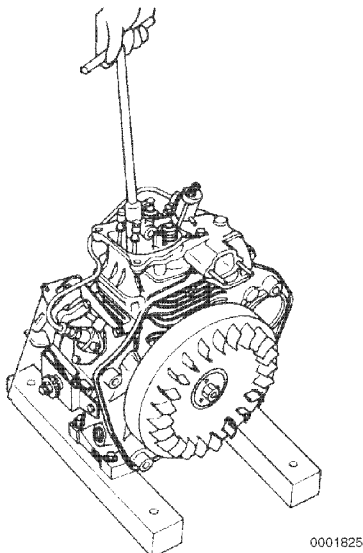

Figure 6-2

Note: Mark the push rods so they can be reinstalled in their original locations.

4. Remove the push rods.

Note: When loosening or tightening the high-pressure fuel line nuts, use a "line" or "flare nut" wrench to prevent rounding of the nuts.

5. Remove the high-pressure fuel injection line, fuel return line and the fuel injector. See *Removal of Fuel Injector on page 7-22*.
6. Remove the two cylinder head nuts and two bolts and remove the cylinder head **(Figure 6-3)**. Discard the cylinder head gasket. Place the cylinder head on a protected work surface to prevent damage to the combustion surface.

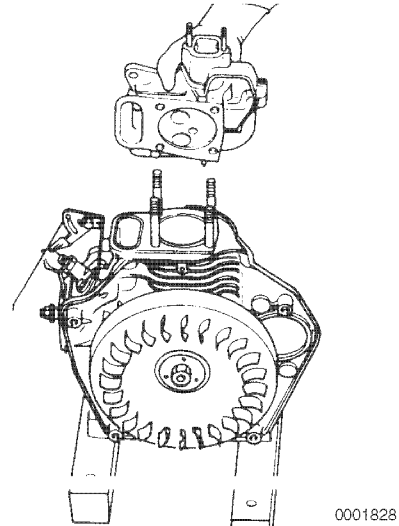

Figure 6-3

Disassembly of Cylinder Head

IMPORTANT

Arrange and mark all components so they can be installed in their original locations.

IMPORTANT

Remove the fuel injector before placing the cylinder head on a work surface. Failure to do so may result in damage to the fuel injector nozzle. See Removal of Fuel Injector on page 7-22.

1. Place the cylinder head on a work bench with the combustion side down.
2. Remove the valve stem caps (**Figure 6-4, (5)**).
3. Use an appropriate valve spring compressor tool to compress the valve springs.
4. Remove the valve keepers (**Figure 6-4, (6)**).
5. Slowly release the tension on the valve spring (**Figure 6-4, (8)**).
6. Remove the spring retainer (**Figure 6-4, (7)**), valve spring (**Figure 6-4, (8)**) and washer (**Figure 6-4, (10)**).
7. Repeat the procedure with the remaining valve.

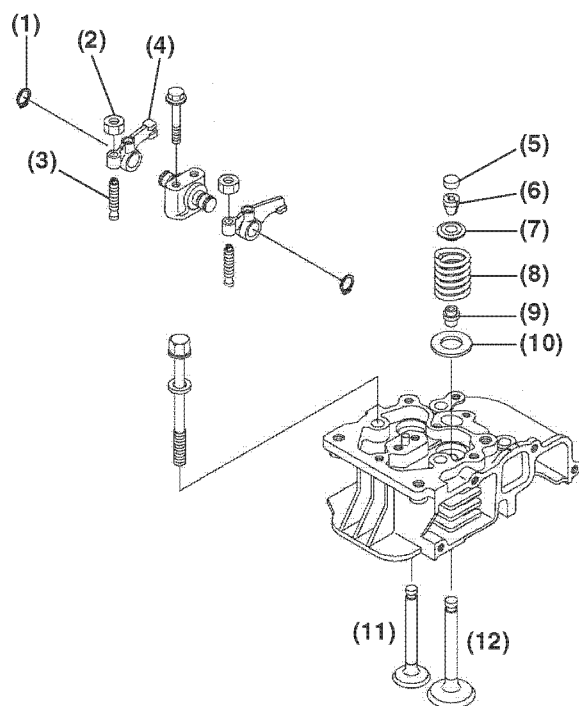

0002391

Figure 6-4

8. Remove the intake (**Figure 6-4, (11)**) and exhaust (**Figure 6-4, (12)**) valves from the cylinder head.
9. Remove the valve stem seals (**Figure 6-4, (9)**).
10. Remove the snap ring (**Figure 6-4, (1)**) from each end of the rocker arm shaft. Remove the rocker arms (**Figure 6-4, (4)**). Identify the rocker arms so they can be installed in their original locations.
11. If necessary, remove the locknut (**Figure 6-4, (2)**) and adjusting screw (**Figure 6-4, (3)**) from each rocker arm.

Inspection of Cylinder Head Components

CAUTION

Any part which is found defective as a result of inspection or any part whose measured value does not satisfy the standard or limit must be replaced.

0000119en

Thoroughly clean all components using a non-metallic brush and an appropriate solvent. Each part must be free of carbon, metal filings and other debris.

Visually inspect all parts. Replace any parts that are obviously discolored, heavily pitted, worn or otherwise damaged. Discard any parts that do not meet the specified limit.

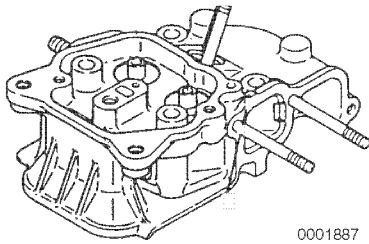

0001887

Figure 6-5

Valve Face and Valve Seat

Always check the clearance between the valve and valve guide before grinding or lapping the valve seats. See *Intake / Exhaust Valves, Guides and Seals on page 6-6* for the service limit. If the clearance exceeds the limit, replace the valve and / or cylinder head to bring the clearance within the limit.

Roughness or burrs will cause poor seating of a valve. Visually inspect the seating surfaces of each valve and valve seat to determine if lapping or grinding is needed.

Visually inspect all valve faces and valve seats for pitting, distortion, cracking or evidence of overheating. Usually the valves and the valve seats can be lapped or ground to return them to serviceable condition. Severely worn or damaged components will require replacement.

Coat the valve seat with a thin coat of bluing compound. Install the valve and rotate it to distribute bluing onto the valve face. The contact pattern should be centered on the valve face (**Figure 6-6, (1)**) and even in width.

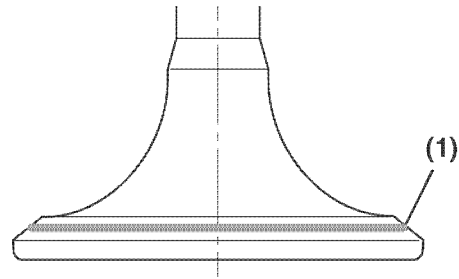

0001691B

Figure. 6-6

Also visually inspect the valve seat for even contact.

Light cutting can be performed by the use of a hand-operated cutter (**Figure 6-7, (3)**).

The valve seat (**Figure 6-7, (2)**) diameter can be adjusted by top-grinding with a 150° stone to make the seat diameter smaller, and bottom-grinding using a 40° stone to make the seat diameter larger. Once the seat location has been corrected, grind and lap the seat angle (**Figure 6-7, (1)**) to specification. See *Cylinder Head* on page 6-5 for specifications.

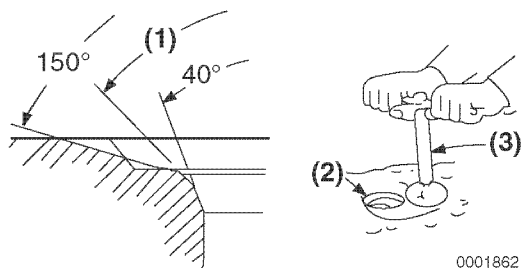

Figure. 6-7

Grind the valve face and / or valve seat only enough to return them to serviceable condition. Grinding is needed if the valve and the valve seat do not contact correctly. See *Valve Recession* on page 6-27.

If the valve or seat require grinding, lap the valve after grinding. Lap the valve face to the valve seat using a mixture of valve lapping compound and engine oil.

Be sure to thoroughly wash all parts to remove all grinding powder or compound.

Valve Recession

Insert the valves into their original locations until they are fully seated. Use a depth micrometer to measure the distance (**Figure 6-8, (2)**) between the cylinder head surface (**Figure 6-8, (1)**) and the combustion surface of each exhaust and intake valve. See *Cylinder Head* on page 6-5 for the service limit. Record the measurement.

Note: If the valve seats are worn or damaged beyond specification, the cylinder head must be replaced. The valve seats are not replaceable parts.

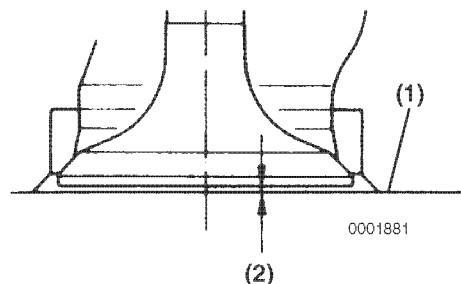

Figure. 6-8

Valves and Valve Guides

Visually inspect the intake and exhaust valves. Replace any valves that are obviously discolored, heavily pitted or otherwise damaged.

Valve Stem Diameter

Use a micrometer to measure the valve stem diameter. Measure the valve stem near the combustion end and near the opposite end (**Figure 6-9, (1)**). See *Intake / Exhaust Valves, Guides and Seals* on page 6-6 for the service limit. Record the measurements.

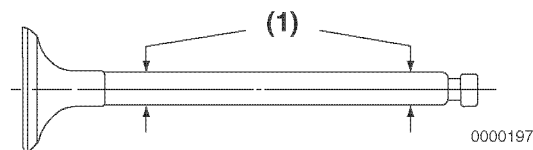

Figure. 6-9

ENGINE

Valve Guides

Visually inspect the valve guides for distortions, scoring or other damage.

Use a telescoping gauge and micrometer to measure the inside diameter of the valve guide. Measure in three places and 90° apart (**Figure 6-10**). See *Intake / Exhaust Valves, Guides and Seals on page 6-6* for the service limit. Replace valve guides if not within specification. Record the measurements.

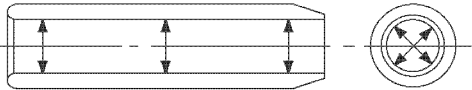

0001869

Figure 6-10

Valve Stem Bend

Place the valve stem on a flat inspection block or layout bed. Roll the valve until a gap can be observed between a portion of the valve stem and the surface of the block or bed. Use a feeler gauge to measure the gap (**Figure 6-11**). See *Intake / Exhaust Valves, Guides and Seals on page 6-6* for the service limit. Record the measurement.

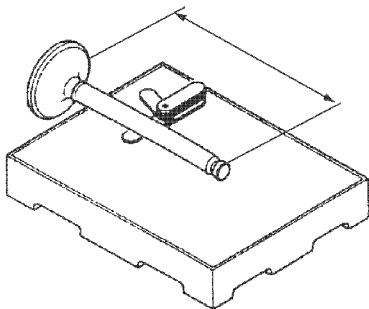

0000199

Figure 6-11

Valve Springs

Inspect the valve springs. If damage or corrosion is seen, or if measurements exceed the specified limits, replace the springs. Record all measurements.

Fractures

Check for fractures on the inside and outside portions of the springs. If the valve spring is fractured, replace the valve spring.

Corrosion

Check for corrosion of the spring material caused by oxidation.

Squareness

Use a flat surface and a square to check each spring for squareness (**Figure 6-12**). See *Valve Spring on page 6-7* for the service limit.

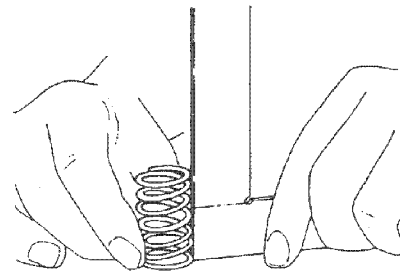

0000201

Figure 6-12

Free Length

Use a caliper to measure the length of the spring (**Figure 6-13**). See *Valve Spring on page 6-7* for the service limit.

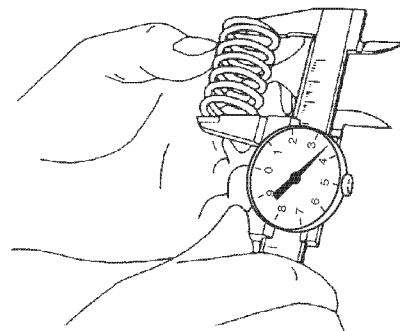

0000200

Figure 6-13

Rocker Arms and Push Rods

Rocker Arm Shaft Outside Diameter

Use a micrometer to measure the rocker arm shaft diameter. Measure at each rocker arm location in two directions, 90° apart (**Figure 6-14**). See *Rocker Arm and Shaft* on page 6-7 for the service limit. Record the measurements.

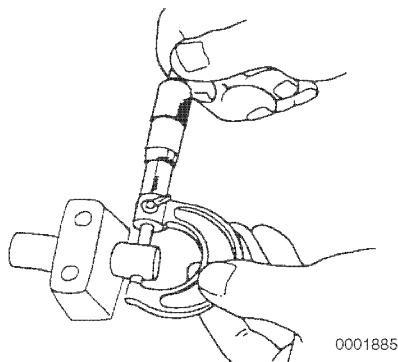

Figure 6-14

Rocker Arm

Use a telescoping gauge and micrometer to measure the inside diameter of the rocker arms (**Figure 6-15**). See *Rocker Arm and Shaft* on page 6-7 for the service limit. Record the measurements.

Inspect the contact areas (**Figure 6-15, (1)**) for excessive wear or damage.

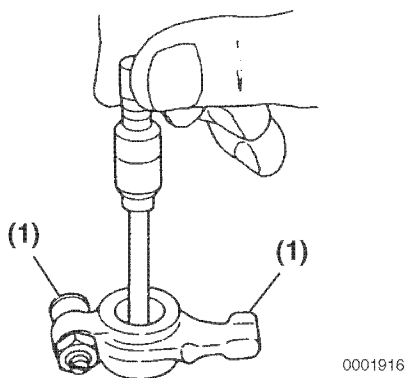

Figure 6-15

Push Rod Bend

Determine if the bend of the push rods are within the specified limit.

1. Place the push rods on a flat inspection block or layout bed.
2. Roll the push rods until a gap can be observed between a portion of the push rod and the surface of the block or layout bed.

Use a feeler gauge to measure the gap (**Figure 6-16**). See *Push Rod* on page 6-6 for the service limit. Record the measurement.

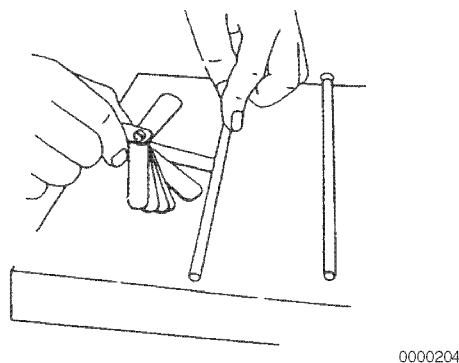
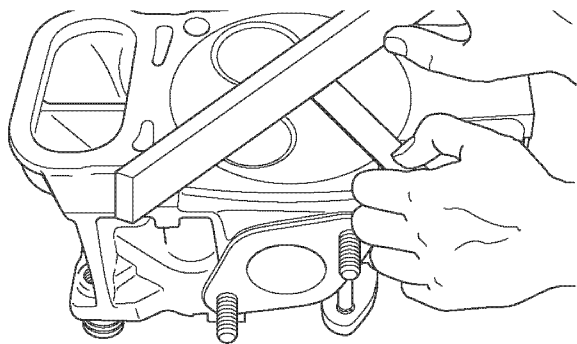

Figure 6-16

Cylinder Head Distortion

Place the cylinder head flat and inverted (combustion side up) on the bench. Use a straightedge and a feeler gauge to measure cylinder head distortion (**Figure 6-17**). Measure diagonally and along each side. See *Cylinder Head* on page 6-5 for the service limit. Record the measurements.



0002401

Figure 6-17

If distortion exceeds the service limit, resurface or replace the cylinder head. Remove only enough material to make the cylinder head flat, but do not remove more than 0.008 in. (0.20 mm).

Reassembly of Cylinder Head

Reassembly of Intake / Exhaust Valves

IMPORTANT

Always install new valve stem seals. The exhaust stem seals can be identified by having yellow paint. Ensure they are installed in the correct locations.

1. Oil the lip of the valve stem seal (Figure 6-18, (2)). Using a valve stem seal installation tool (Figure 6-18, (1)), install a new valve stem seal on each of the valve guides (Figure 6-18, (3)).

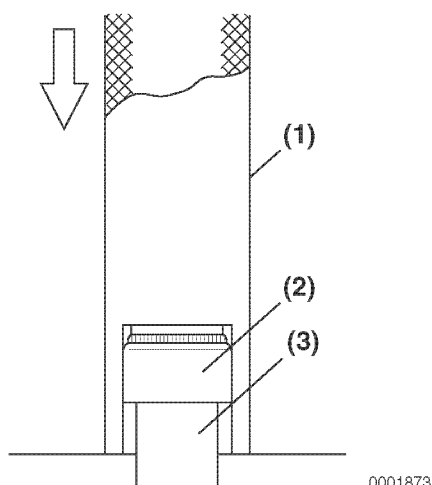

Figure 6-18

Note: Be sure the valve-spring washer is not installed on the cylinder head.

2. Measure the distance (Figure 6-19, (1)) from the machined spring seat surface of the cylinder head to the top of the valve stem seal to ensure there is proper clearance (Figure 6-19, (2)) between the guide and the seal. See *Intake / Exhaust Valves, Guides and Seals* on page 6-6 for Valve Seal Installed Height Specifications.

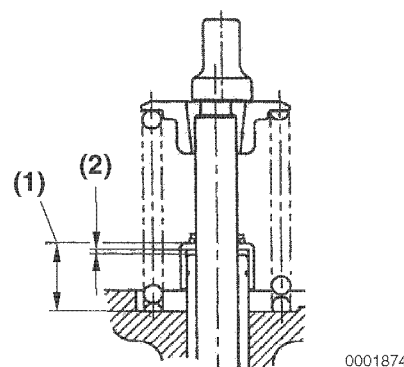

Figure 6-19

3. Place the valves (Figure 6-21, (11, 12)) in their proper locations in the cylinder head.

IMPORTANT

L100N models: Position the Yellow paint mark (Figure 6-20, (1)) on the valve spring toward the cylinder head during assembly.

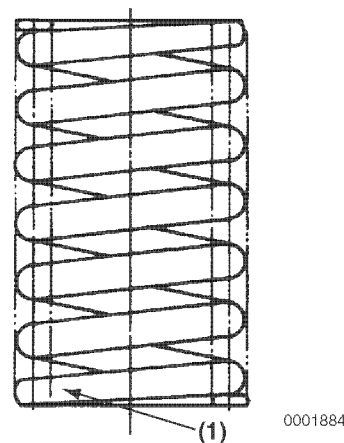
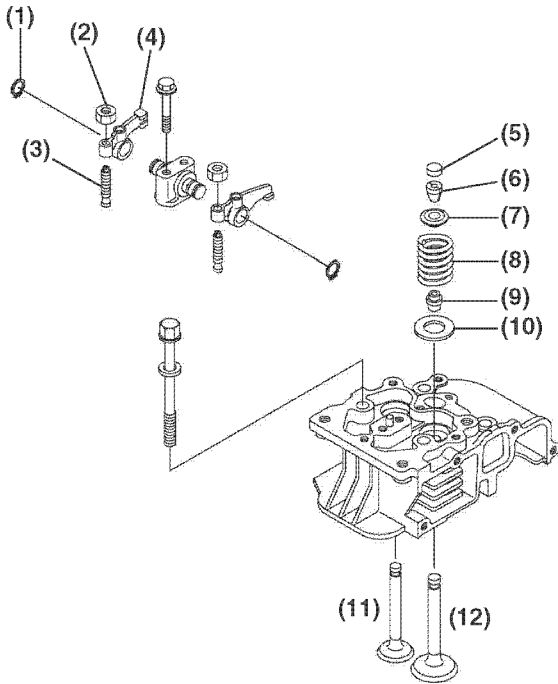

Figure 6-20

ENGINE

- Place the cylinder head on the workbench with the combustion side down. Install the washer (Figure 6-21, (10)), valve spring (Figure 6-21, (8)) and spring retainer (Figure 6-21, (7)).



0002391

Figure 6-21

- Using an appropriate valve spring compressor tool, compress the valve spring.
- Insert the valve keepers (Figure 6-21, (6)) and slowly release the tension on the valve spring. Install the valve cap (Figure 6-21, (5)). Repeat the steps on the remaining valve.
- Install the rocker arms (Figure 6-21, (4)) on the rocker shaft. Secure with a snap ring (Figure 6-21, (1)) on each end. If removed, install the adjuster screws (Figure 6-21, (3)) and locknuts (Figure 6-21, (2)) in each rocker arm.

Installation of Cylinder Head

1. Carefully clean the gasket surfaces of the cylinder head and the cylinder block.
2. Install a new push rod cavity O-ring.
3. Select and install a cylinder head gasket. See *Calculating Cylinder Head Gasket Thickness on page 6-34*.
4. Install the cylinder head.

Note: Install the cap nuts (**Figure 6-22, (2)**) on the studs that will be covered by the rocker arm cover.

5. Lightly oil the threads of the cylinder head studs. Install the washers (**Figure 6-22, (1)**) and nuts. Tighten to the specified torque in two steps as shown in the chart below. Tighten in an "X" pattern. See *Special Torque Specifications on page 6-18* for torque values.

First Step	1/2 of final torque
Second Step	Final torque

6. Insert the push rods in their respective positions. Ensure the push rods are seated in the tappets.
7. Place the valve caps (**Figure 6-22, (4)**) on the valve stem tips.
8. Install the rocker arm shaft assembly (**Figure 6-22, (3)**). Be sure the alignment pin (**Figure 6-22, (5)**) is in place.
9. Install and tighten the rocker arm shaft bolts to the specified torque. See *Special Torque Specifications on page 6-18* for torque values.

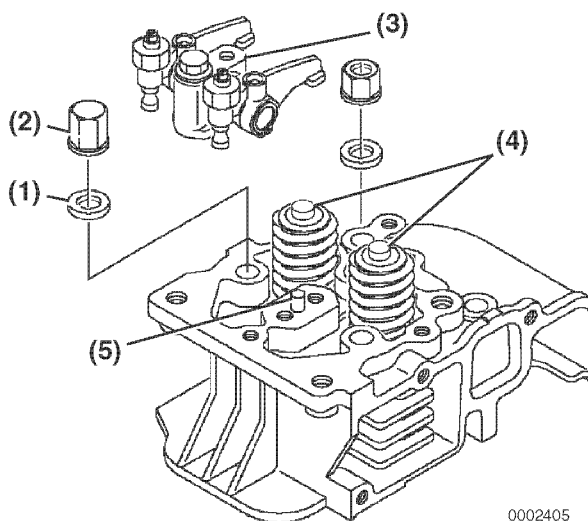

0002405

Figure 6-22

Calculating Cylinder Head Gasket Thickness

1. Rotate the flywheel until the TDC (Top Dead Center) mark on the flywheel (**Figure 6-23, (2)**) aligns with the left-hand edge of the timing reference "notch" on the cylinder cooling fin (**Figure 6-23, (1)**).

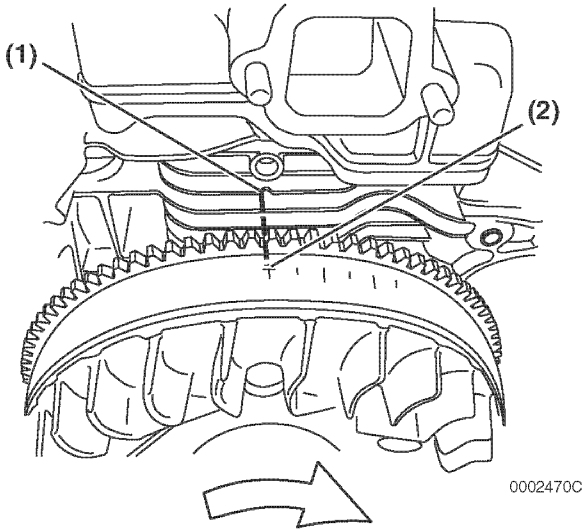

Figure 6-23

2. Place a wooden wedge between the flywheel and crankcase to hold the flywheel and crankshaft stationary.
3. Use a depth micrometer to measure the distance (**h**) from the cylinder block surface (**Figure 6-24, (2)**) to the top of the piston (**Figure 6-24, (1)**). Be careful to avoid the valve relief pockets and any marks stamped on the piston. Take the average of two measurements, 180° apart and in line with the piston wrist pin and record the measurement (**h**).

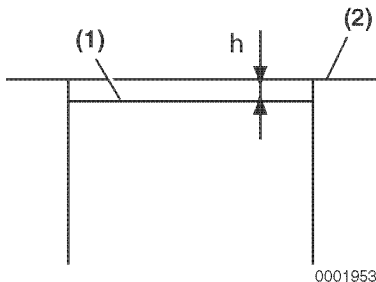

Figure 6-24

4. Subtract the measured value (**h**) from both the minimum and maximum values in the chart below **Figure 6-25** for the engine model being serviced.

Model	Minimum	Maximum
L48N	0.0215 in. (0.546 mm)	0.0235 in. (0.596 mm)
L70N	0.0218 in. (0.553 mm)	0.0239 in. (0.603 mm)
L100N	0.0222 in. (0.563 mm)	0.0241 in. (0.613 mm)

Figure 6-25

5. Choose a gasket thickness from the chart **Figure 6-27** that is between the two calculated values:

Example: If the average of the two measurements is (**h**) = 0.006 in. (0.157 mm) for a model L70N, the calculations would look like this:

- English Calculation:
Minimum - (0.0218 - 0.006 = 0.0158 in.)
Maximum - (0.0239 - 0.006 = 0.0179 in.)
- Metric Calculation:
Minimum - (0.553 - 0.157 = 0.396 mm)
Maximum - (0.607 - 0.157 = 0.450 mm)
- In this case, the head gasket required must be between 0.0158 and 0.0179 in. (0.396 mm and 0.450 mm) in thickness. The gasket to use would be the gasket that is 0.016 in. (0.40 mm) in thickness and would have an identification mark of 40.

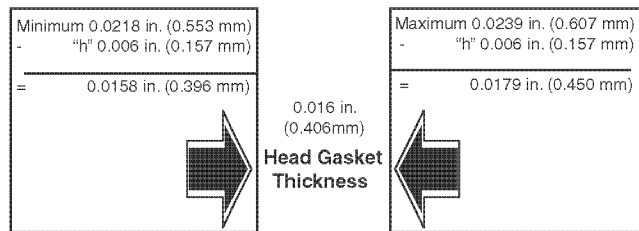

0003597

Figure 6-26

Note: If your calculation indicates the need for a thinner head gasket than those available, this would be an indication of damage to the connecting rod (bent) or connecting rod bearing (worn).

Available Cylinder Head Gasket Sets
 (The cylinder head gaskets are sold in sets of five (5) gaskets, one of each thickness.)
 The identification number is marked on each head gasket.

Cylinder Head Gasket Set Part Number		Thickness Identification Mark				
		0.016 in. (0.40 mm)	0.018 in. (0.45 mm)	0.020 in. (0.50 mm)	0.022 in. (0.55 mm)	0.024 in. (0.60 mm)
L48N	114771-01330	ID 40	ID 45	ID 50	ID 55	ID 60
L70N	114871-01330					
L100N	114651-01330					

Figure 6-27

Checking Actual Piston TDC (Top Dead Center)

Due to variations in machined and cast parts and assembly procedures, the TDC timing mark on the flywheel may not always align accurately with piston TDC mark on the cooling fin, misrepresenting true TDC piston position.

Indexing the flywheel to the actual piston TDC, provides an accurate measurement of the piston position in the cylinder to the TDC timing mark on the flywheel.

It is recommended that the flywheel be indexed any time the flywheel is removed from the crankshaft and before adjusting fuel Injection timing. See *Adjusting Fuel Injection Timing on page 7-14*.

Indexing the flywheel to true TDC involves using the engine intake valve as a piston stop to rotate the piston against, in both directions of rotation. At each rotational stop, a mark is placed on the cooling fin where the TDC mark on the flywheel stops. This will provide two new marks on the cooling fin, one on each side of the existing TDC mark. The mid point between the two new marks is true TDC.

1. Close all fuel supply valves to the fuel injection pump.

IMPORTANT

Always use a wrench to hold the fuel injection pump fuel delivery valve to prevent loosening of the delivery valve when loosening or tightening the high-pressure fuel injection lines.

Note: To prevent "rounding" the fuel line nuts, always use a "line" or "flare nut" wrench.

2. To prevent accidental engine starting, loosen the high-pressure fuel injection line nuts at each fuel injector and the fuel injection pump to drain fuel from the lines.

Note: Some fuel may drain from the fuel injection pump during this process. Make provisions to contain spills.

3. Remove the rocker arm (valve) cover bolts, valve cover and gasket. Discard the gasket.
4. Remove the intake valve adjustment screw lock nut from the intake valve rocker arm (**Figure 6-28, (3)**) of No. 1 cylinder, and back out the adjustment screw (**Figure 6-28, (2)**) enough to remove the push rod.

Note: The use of a "bridge" tool is needed to support the valve adjustment screw and open the valve. Use a suitable tool that allows adjustment of the valve adjustment screw. An 8 to 10 mm hex wrench is shown as an example in (**Figure 6-28, (1)**).

5. Insert the bridge tool across the top surface of the cylinder head to support the valve adjustment screw.

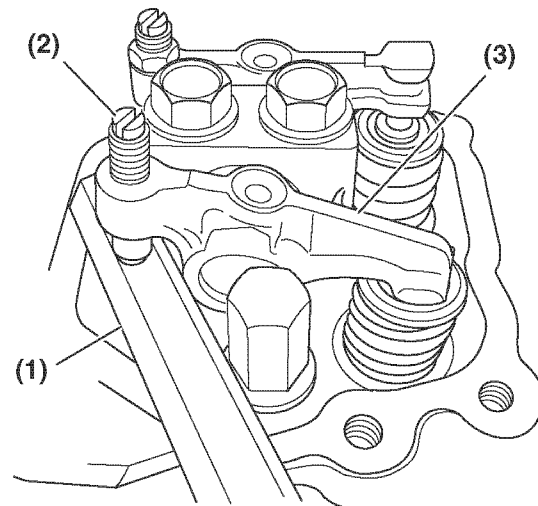

0002898A

Figure 6-28

6. Rotate the flywheel to position the existing TDC mark at approximately 90° BTDC (**Figure 6-29**).

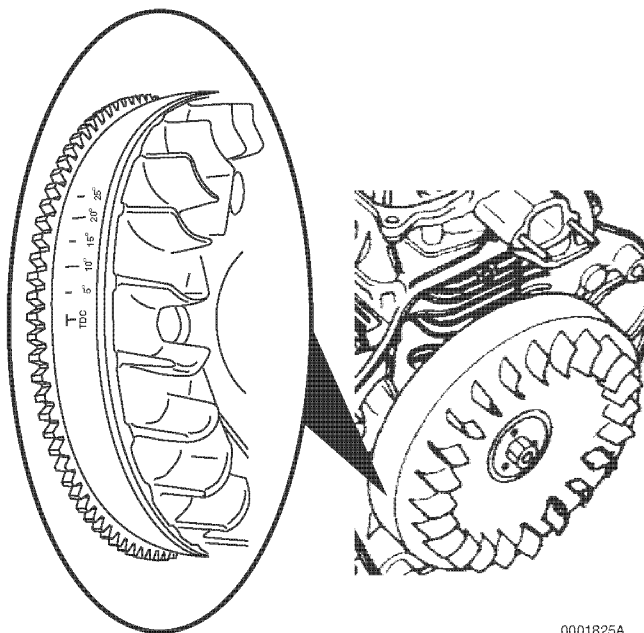

Figure 6-29

7. Turn the valve adjustment screw in against the bridge tool to open the intake valve into the cylinder to act as a piston stop.
8. Carefully rotate the flywheel in a clockwise (**Figure 6-30, (5)**) direction to allow the piston to contact the intake valve. Measure the distance from the existing TDC mark (**Figure 6-30, (1)**) on the cooling fin to the TDC mark on the flywheel (**Figure 6-30, (3)**) (where the flywheel stopped).

The valve should contact the piston approximately 30 - 40 mm BTDC.

9. If the valve does not contact the piston within the range, carefully rotate the flywheel counterclockwise away from the valve, readjust the screw to bring the contact distance into range and rotate the flywheel clockwise again to stop the piston at the valve. Recheck the measurement and repeat as necessary to bring the measurement within the range.

10. With the piston in contact with the intake valve, use a straightedge (**Figure 6-30, (4)**) and scribe or fine point marker to transfer the position of the flywheel TDC mark (**Figure 6-30, (2)**) to the cooling fin.

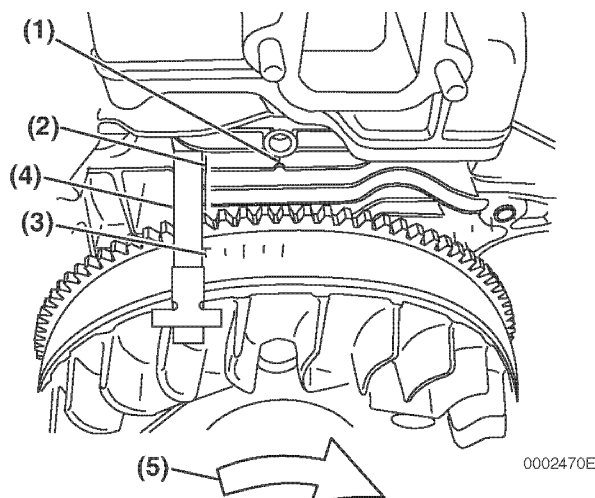

Figure 6-30

11. Carefully rotate the flywheel counterclockwise (**Figure 6-31, (1)**) completely around to allow the piston to contact the valve from the other side.
12. With the piston in contact with the intake valve, use a straightedge (**Figure 6-31, (4)**) and scribe or fine point marker to transfer the position of the flywheel TDC mark (**Figure 6-31, (3)**) to the cooling fin (**Figure 6-31, (2)**).

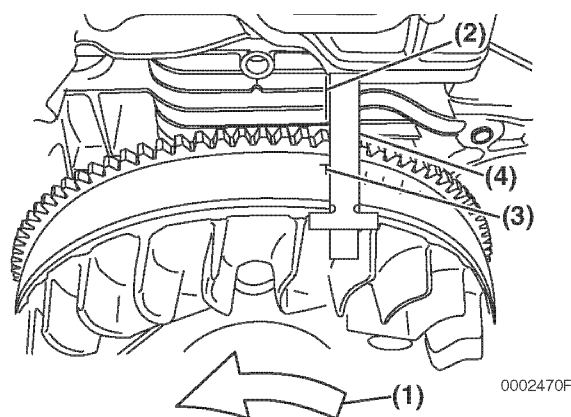
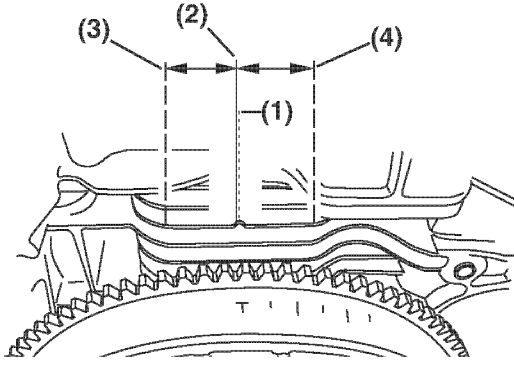

Figure 6-31

ENGINE

13. Using a caliper, measure the distance between the two new marks on the cooling fin (Figure 6-32, (3, 4)).
14. The mid point (Figure 6-32, (2)) (divide the distance by 2) of the distance measured is the new TDC cooling fin mark. Use a scribe or fine point marker to mark this position on the cooling fin as the new true piston TDC. Figure 6-29 illustrates an example.



- | | |
|---------------------------------|---|
| 1 – Original TDC
Timing Mark | 3 – Left Piston Stop
Timing Mark |
| 2 – New TDC
Timing Mark | 4 – Right Piston
Stop Timing
Mark |

Figure 6-32

15. Loosen the valve adjustment screw and remove the bridge tool.
16. Install the intake valve push rod.
17. Install the intake valve adjustment screw lock nut on the adjustment screw.
18. Adjust the valve clearance. *See Measuring and Adjusting Valve Clearance on page 6-39.*
19. Install a new rocker arm (valve) cover gasket.
20. Install the rocker arm (valve) cover and bolts.
21. Tighten the high pressure fuel injection line nuts on each fuel injector and on the fuel injection pump to specification. *See Special Torque Specifications on page 7-4.*
22. Open all fuel supply valves to the fuel injection pump.
23. Prime the fuel system. *See Priming the Fuel System on page 4-12.*

Measuring and Adjusting Valve Clearance

Note: The engine should be cold before adjusting valve clearance.

To adjust valve clearance, the piston must be at or near TDC of the compression stroke. When the piston is at TDC of the compression stroke, both the intake and exhaust valves will be closed and both rocker arms will be loose.

If the cooling fan housing is removed, the TDC mark on the flywheel can be aligned with the TDC mark on the cooling fin to locate piston TDC of the compression stroke.

If the cooling fan housing is not removed, piston TDC of the compression stroke may be found by rotating the flywheel and watching each valve open and close. Rotate the flywheel clockwise, allowing the exhaust valve to open then close, and then the intake valve to open and close. After the intake valve has closed, rotate the flywheel clockwise an additional 1/4 turn. At this position the piston will be on the compression stroke and both valves will be closed allowing valve clearance adjustment to be completed.

1. Remove the rocker arm (valve) cover bolts, valve cover and gasket. Discard the gasket.
2. Rotate the crankshaft to piston TDC of the compression stroke.
3. Check the valve clearance (**Figure 6-33, (1)**) using a feeler gauge. If adjustment is required, proceed to the next step. See *Valve Clearance on page 6-5* for the specification.
4. Loosen the adjusting screw locknut (**Figure 6-33, (3)**). Turn the valve adjustment screw (**Figure 6-33, (2)**) to adjust the valve clearance so there is a slight "drag" on the feeler gauge when sliding it between the rocker arm and the valve cap. Hold the adjusting screw while tightening the valve adjusting screw locknut. Recheck the clearance.

Standard Intake/Exhaust Valve Clearance - All Models
0.006 ± 0.002 in. (0.15 ± 0.05 mm)

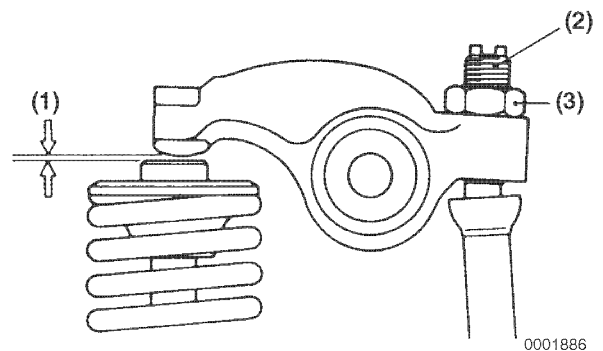

Figure 6-33

Note: There is a tendency for the clearance to decrease slightly when the locknut is tightened. It is suggested that you make the initial clearance adjustment slightly on the "loose" side before tightening the locknut. Recheck the clearance after tightening the locknut.

5. Apply oil to the contact surface between the adjusting screw and push rod.
6. Install a new rocker arm (valve) cover gasket.
7. Install the rocker arm (valve) cover and bolts.

ENGINE

Removal of Engine

Prepare a clean, flat work surface on a workbench large enough to accommodate the engine components.

1. Disconnect the battery cables (if equipped), negative (-) cable first.
2. Drain the engine oil. *See Replace Engine Oil on page 5-25.*
3. Turn off any fuel valves. Disconnect the fuel supply and fuel return lines at the engine.
4. Disconnect the throttle cable, any external engine shut-off linkage, external compression release linkage and any external wire connectors.
5. Remove all engine mount fasteners and remove the engine from the machine. Secure the engine to a solid base.

CAUTION

Be sure to secure the engine solidly to prevent injury or damage to parts due to the engine falling during work on the engine.

000009en

6. Clean the engine by washing with solvent, air or steam cleaning. Cover or plug any open connectors, hoses or fittings to prevent any foreign matter from entering the engine during cleaning.

7. Remove the engine-mounted fuel tank (if equipped) (**Figure 6-34**).

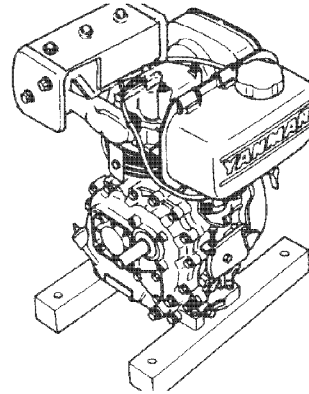

0001832

Figure 6-34

8. Remove the exhaust muffler (**Figure 6-35**).

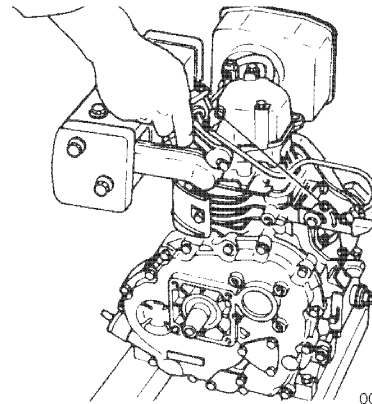

0001833

Figure 6-35

9. Remove the air cleaner cover.
10. Remove the filter element (**Figure 6-36**).
11. Remove the air cleaner housing.

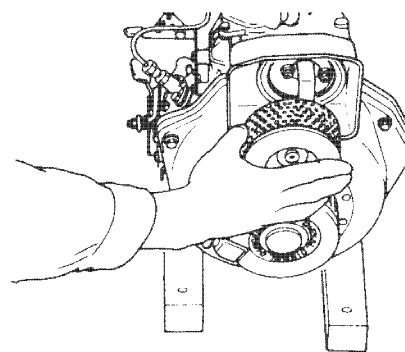

0001834

Figure 6-36

12. Remove the recoil starter and starter pulley.
(The recoil starter and cooling fan may be removed as an assembly if the recoil assembly does not require service.)
13. Remove the cooling fan housing (**Figure 6-37**).
14. Remove the starter pulley from the flywheel (**Figure 6-37, (1)**).

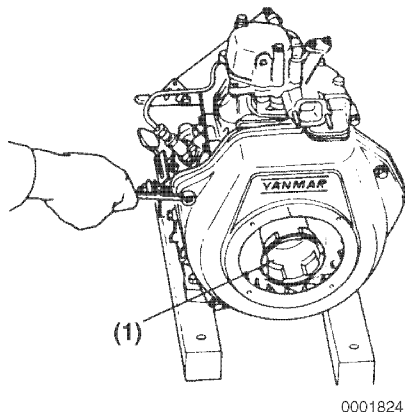

Figure 6-37

- IMPORTANT**
Mark all valve train components so they can be installed in their original locations.
17. Remove the cylinder head assembly. See *Removal of Cylinder Head* on page 6-24.
 18. Remove the fuel injection pump (**Figure 6-39**). See *Removal of Fuel Injection Pump* on page 7-16.

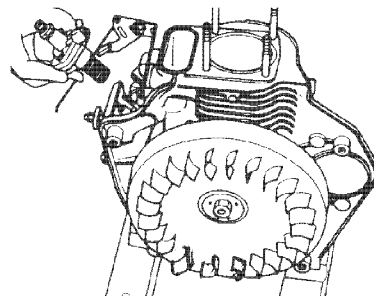

Figure 6-39

15. Remove the air intake manifold (**Figure 6-38**).

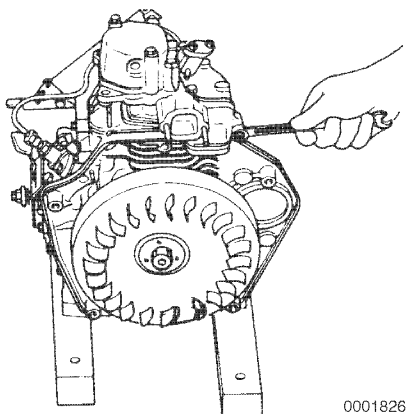

Figure 6-38

16. Remove the starter motor (if equipped).

ENGINE

Disassembly of Engine

Note: Before performing any of the following procedures, first perform procedures in, *Removal of Engine on page 6-40.*

1. If not already completed, remove the cylinder head assembly. See *Removal of Cylinder Head on page 6-24.* If the cylinder head requires service, it should be done at this time. See *Disassembly of Cylinder Head on page 6-25.*

IMPORTANT

Discard all used gaskets, O-rings and seals during assembly.

Note: Record all measurements taken during disassembly.

2. Remove the flywheel and stator assembly. See *Removal of Stator on page 9-16.*
3. Remove the crankcase cover **Figure 6-40** and oil pump assembly.

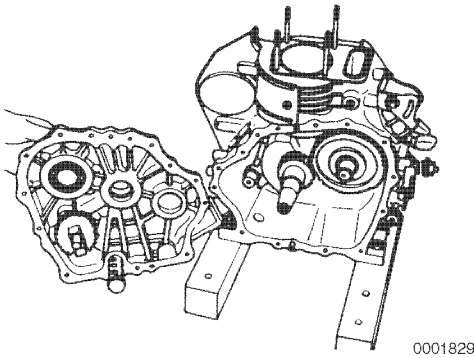

Figure 6-40

4. Position the engine with the open crankcase end facing up.

Note: Before removing the camshaft, rotate the camshaft at least two turns to “bump” any sticking tappets away from the camshaft.

Note: Identify the location of the camshaft gear and crankshaft gear alignment marks (**Figure 6-41**). These marks are important for reassembly.

5. Remove the camshaft by pulling it straight up and out of the crankcase.

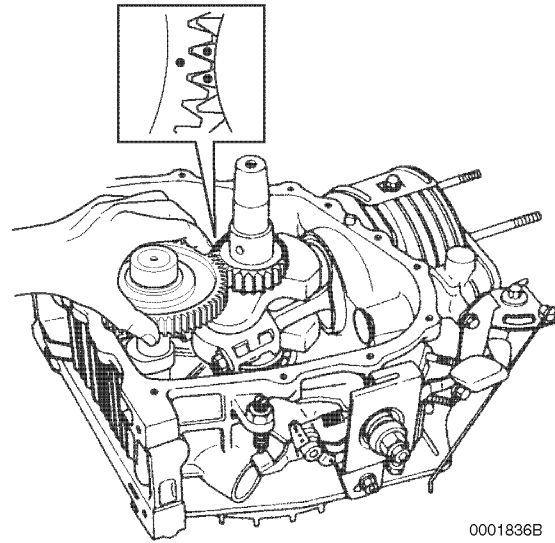

Figure 6-41

Note: The tappets are “mushroom” shaped and must be removed from inside the engine crankcase.

6. Remove the tappets. Mark the tappets so they can be reinstalled in the same location.
7. Remove the balancer **Figure 6-42** shaft by pulling it up and out of the crankcase, rotating as necessary for clearance. As with the camshaft, note the alignment marks where the balancer shaft gear meshes with the crankshaft gear.

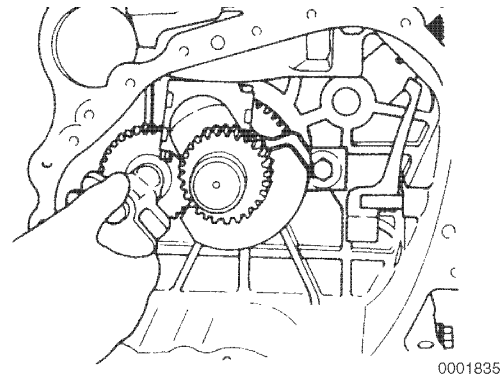

Figure 6-42

8. Measure bearing oil clearance prior to removing the piston and connecting rod to determine the extent of wear. Record the measurements.
 - (a) Remove the bearing cap. Do not remove the bearing inserts at this time.
 - (b) Wipe oil from the bearing insert and crankshaft journal surfaces.
 - (c) Place a piece of PLASTIGAGE® **(Figure 6-43, (1))** along the full width of the bearing insert.

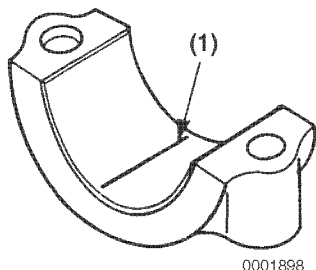

Figure 6-43

IMPORTANT

Do not rotate the crankshaft when using PLASTIGAGE. A false reading may result.

- (d) Install the bearing cap and tighten to specification. *See Special Torque Specifications on page 6-18.*
- (e) Remove the bearing cap.

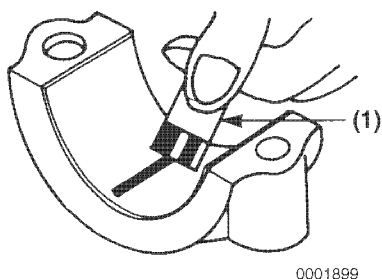

Figure 6-44

- (f) Compare the width of the flattened PLASTIGAGE to the graduation marks on the package **(Figure 6-44, (1))**. The mark that most closely matches the width of the flattened PLASTIGAGE will indicate the bearing oil clearance. See *Crankshaft, Balancer Shaft, Piston and Connecting Rod on page 6-8* for the wear limit.

IMPORTANT

The piston can fall from the cylinder block if the engine is inverted. Position the engine so the connecting rod is horizontal before removing the connecting rod cap.

Do not allow the connecting rod to contact the crankshaft journal during piston removal. Damage to the bearing journal may result.

High hour engines may have carbon buildup or a ridge near the top of the cylinder that will catch the piston rings and make it impossible to remove the piston from the top of the cylinder block. Use a suitable ridge reamer to remove ridges and carbon prior to removing the piston.

9. Remove the connecting rod bolts **(Figure 6-45)**.
10. Remove the connecting rod cap.

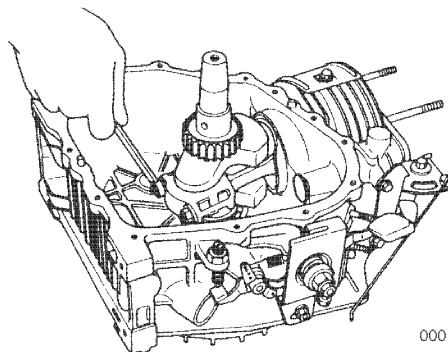
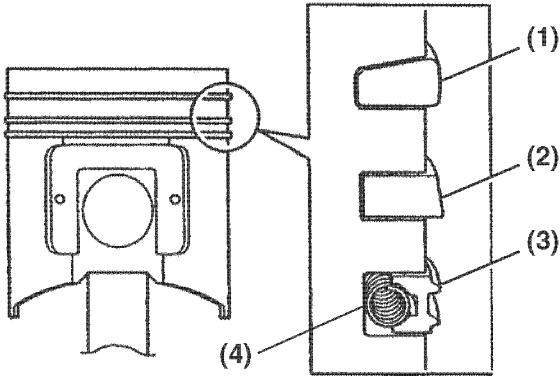

Figure 6-45

11. Rotate the crankshaft to the top of the stroke and push the piston and connecting rod out the top of the cylinder.
12. Remove the compression rings **(Figure 6-46, (1, 2))** from the piston using a piston ring expander.

ENGINE

13. Remove the oil ring (**Figure 6-46, (3)**) and oil ring expander (**Figure 6-46, (4)**) from the piston using a piston ring expander.



0001722B

Figure 6-46

14. Remove the wrist pin circlips (**Figure 6-47, (1)**) from the piston.

 WARNING

BURN HAZARD!
<ul style="list-style-type: none">• Handle hot components with heat-resistant gloves.• Failure to comply could result in death or serious injury.
0000110en

Note: The wrist pin is a light press-fit in the piston and may require driving out. If heating of the piston is necessary, heat the piston in an oven or in hot oil to 158° - 176°F (70° - 80°C). Support the piston to prevent damage to the piston as the wrist pin is driven out.

15. Support the piston (**Figure 6-47, (3)**) and drive the wrist pin (**Figure 6-47, (4)**) from the piston. Use a soft-faced hammer and a suitable driving tool that has a smaller diameter than the inside diameter of the wrist pin bore. Remove the connecting rod (**Figure 6-47, (2)**) from the piston.

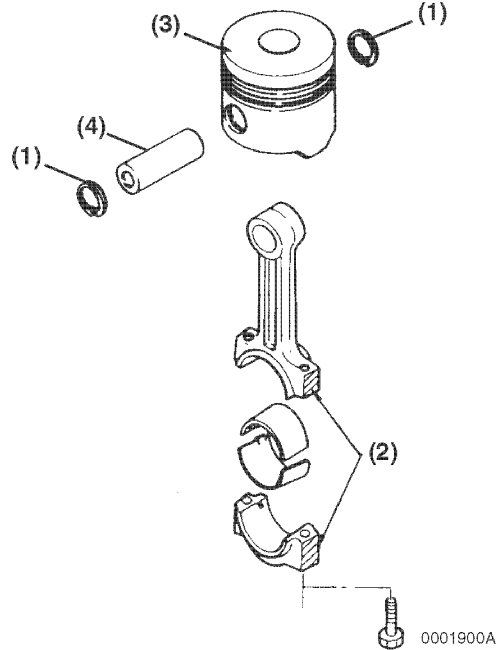

0001900A

Figure 6-47

16. Remove the crankshaft bearing retainer fastener and bearing retainer (**Figure 6-48, (1)**) from inside the crankcase.

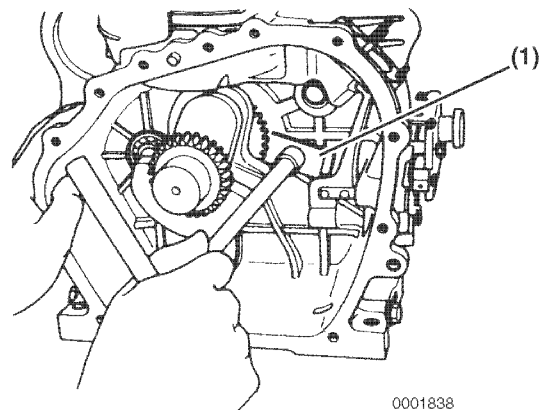

0001838

Figure 6-48

17. Remove the crankshaft from the open end of the crankcase. It will be necessary to use a heavy soft-faced hammer to drive the crankshaft out of the crankcase and drive the large main bearing out. Reinstall the flywheel nut to protect crankshaft threads while driving crankshaft and large bearing out. Keep crankshaft aligned as it is driven out by supporting the opposite crankshaft end (Figure 6-49).

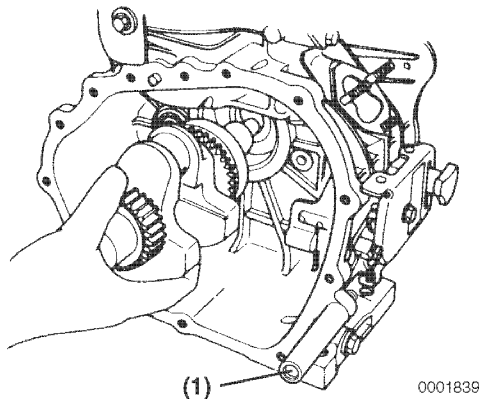

Figure 6-49

IMPORTANT

Do not attempt to adjust or remove the fuel limiter (Figure 6-49, (1)) assembly from the crankcase.

18. Remove the governor and speed control mechanism only if necessary. If governor components or seal must be replaced. See *Replacement of Throttle Shaft Seal - L48N Models on page 6-56* or *Replacement of Throttle Shaft Seal - L70N and L100N Models on page 6-57*.

Inspection of Engine Components

Piston, Piston Rings and Wrist Pin

Notes:

- On an engine with low hours, the piston and piston rings may be reused if they are found to be within specifications.
 - On an engine with high hours, the piston rings should be replaced and the cylinder honed (see *Honing and Boring on page 6-52*) or replaced. The piston should be replaced as necessary.
1. Clean piston ring grooves using a piston ring groove cleaning tool. Follow manufacturer's instructions for correct operation.
 2. Wash the piston in an appropriate solvent using a soft brush.
 3. Visually inspect the piston for cracks. Pay particular attention to the ring lands between the piston ring grooves.
 4. Measure the diameter of the piston skirt at 90° to the wrist pin bore as shown (Figure 6-50). Measurements must be taken at a specified distance (Figure 6-50, (1)) from the bottom of the piston, based on engine model. Record the measurements. See *Piston on page 6-10* for specifications.

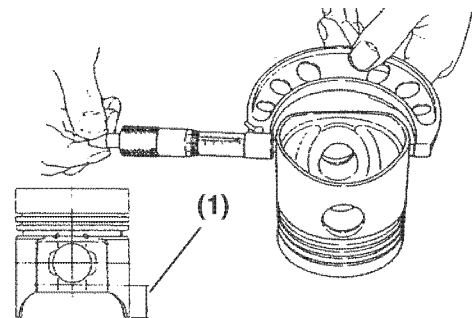

Figure 6-50

5. Subtract the piston measurement from the greatest measurement acquired during cylinder inspection (see *Cylinder Bore on page 6-51*) to obtain piston-to-cylinder clearance. Record the measurements. See *Piston on page 6-10* for specifications.
6. Measure the diameter of the wrist pin bore on both sides of the piston (**Figure 6-51**). See *Piston on page 6-10* for specifications. Record the measurements.

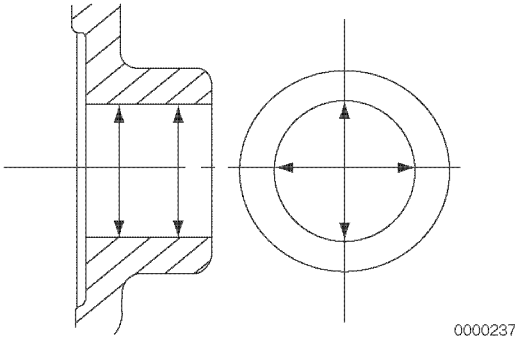

Figure 6-51

7. Measure the outside diameter of the wrist pin in three places and at 90° (**Figure 6-52**). See *Piston on page 6-10* for specifications. Record the measurements.

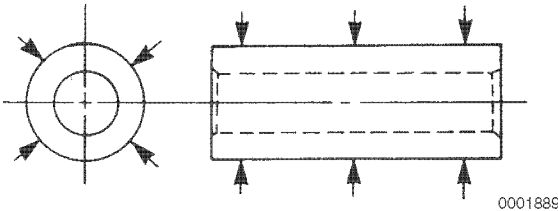

Figure 6-52

8. Using a micrometer, measure the thickness of each piston ring. See *Piston Ring on page 6-11* for specifications. Record the measurements.

Notes:

- On an engine with low hours, the piston, piston rings and cylinder may be reused if they are found to be within specifications.

- On an engine with high hours, the piston rings should be replaced and the cylinder honed (see *Honing and Boring on page 6-52*) or replaced. The piston should be replaced as necessary.

9. Place each compression piston ring in the groove as shown (**Figure 6-53**). Use a feeler gauge to measure the clearance between the piston ring and the piston ring land. Record the measurements. See *Piston Ring on page 6-11* for specifications. Replace the piston if not within specification.

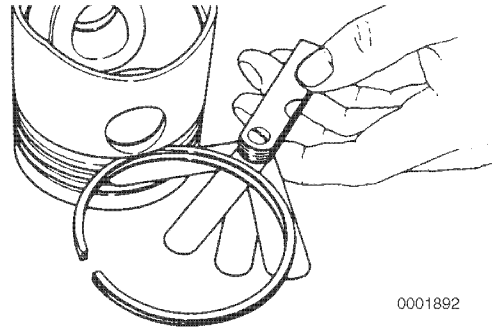

Figure 6-53

10. To measure piston ring end gap, insert each compression piston ring (**Figure 6-54, (1)**), one at a time, into the cylinder. Use a piston with the piston rings removed to slide the ring into the cylinder bore until it is approximately 1.18 in. (30 mm) (**Figure 6-54, (2)**) from the bottom of the bore.

11. Remove the piston. Measure the end gap (**Figure 6-54, (3)**) of each piston ring. Record the measurements. See *Piston Ring on page 6-11* for specifications.

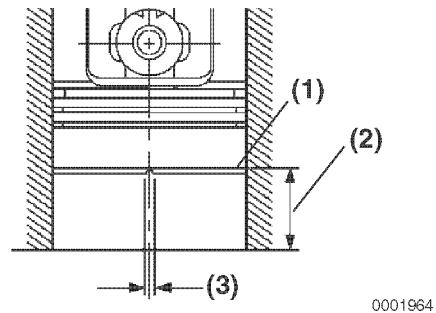

Figure 6-54

Note: Always check the piston ring end gap when installing new piston rings. See *Piston Ring* on page 6-11 for specifications. Use a piston ring end gap filing tool to adjust the piston ring end gap on new piston rings.

Connecting Rod

1. Measure the wrist pin bushing bore using a bore gauge (**Figure 6-55, (1)**). Record the measurement. Replace the bushing if not within specifications. If the bushing has been removed, measure the inside diameter of the connecting rod small end (**Figure 6-55, (2)**). See *Connecting Rod* on page 6-13 for specifications.

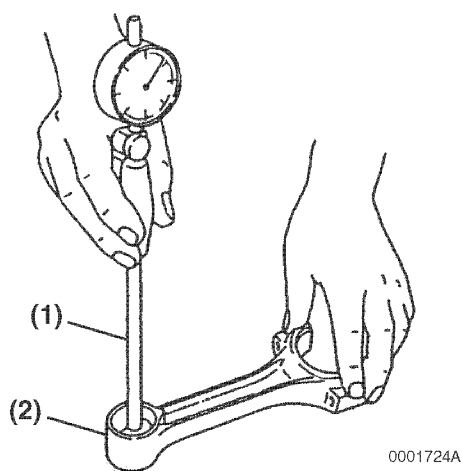

Figure 6-55

2. Inspect the bearing insert for separation or damage (**Figure 6-56**).

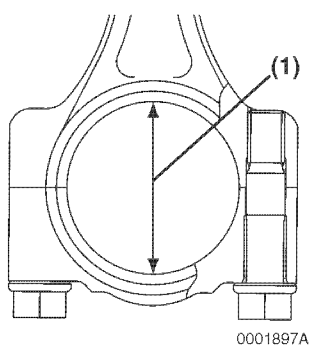

Figure 6-56

3. Place the connecting rod bearing inserts into the connecting rod and connecting rod cap. Install the rod cap and tighten the bolts to the specified torque.
4. Measure the inside diameter (**Figure 6-56, (1)**). Record the measurement. Compare the measurement with crankshaft rod journal outside diameter to calculate oil clearance. See *Crankshaft* on page 6-8 and *Piston* on page 6-10 for specifications.
5. Check for twist (**Figure 6-57, (1)**) and bend (**Figure 6-57, (2)**). See *Connecting Rod* on page 6-13 for the service limit. Record all measurements.

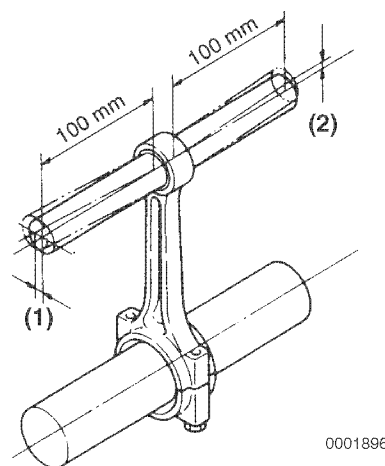

Figure 6-57

ENGINE

Crankshaft, Main Bearing and Flywheel

Clean the cylinder block and crankcase cover.
Clean out each oil passage.

Do not remove plugs from the cylinder block or crankcase cover unless they are damaged or show evidence of leakage.

Replacement of Flywheel Ring Gear

Inspect the ring gear teeth for excessive wear or damage. Replace if necessary.

CAUTION



FLYING OBJECT HAZARD!

- **ALWAYS** wear eye protection when servicing the engine and when using compressed air or high-pressure water. Dust, flying debris, compressed air, pressurized water or steam may injure your eyes.
- Failure to comply may result in minor or moderate injury.

000003en

1. Drive a chisel between two ring gear teeth to split the ring gear. Remove the ring gear from the flywheel.

WARNING



BURN HAZARD!

- Handle hot components with heat-resistant gloves.
- Failure to comply could result in death or serious injury.

0000110en

2. Carefully support the flywheel on cooling fan side (**Figure 6-58, (5)**). Heat the new ring gear to approximately 356°F (180°C).
3. Place the heated ring gear (**Figure 6-58, (2)**) onto the flywheel (**Figure 6-58, (3)**) with the chamfer on the teeth (**Figure 6-58, (1)**) facing toward the engine (**Figure 6-58, (4)**). Tap lightly with a hammer to ensure it is fully seated.
4. Allow the assembly to slowly cool.

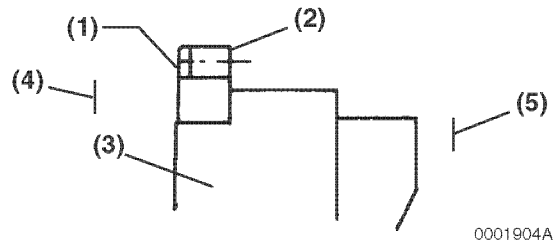

Figure 6-58

Crankshaft

1. Inspect the crankshaft for fractures using either the colorcheck method or the MAGNAFLUX® method. Replace the crankshaft if evidence of fractures are found.
2. Measure the outside diameter of the crankpin (**Figure 6-59, (2)**) and main bearing journals. Take measurements at several places around each bearing surface. If not within specification, grind the journal(s) and install undersize bearings, or replace the crankshaft. See *Crankshaft on page 6-8* for the service limit. Record the measurements.

Note: The ball bearing (**Figure 6-59, (3)**) on the flywheel end is press-fit onto the crankshaft (**Figure 6-59, (4)**). Replace the crankshaft if the bearing fit is loose.

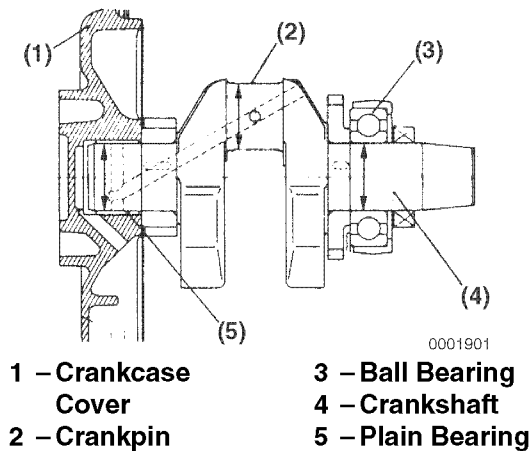

Figure 6-59

- Roll the ball bearing and check for roughness.

Bearings

Inspect the main bearing (**Figure 6-60, (1)**) for discoloration, separation or other damage.

Also inspect the balancer and cam bearings for wear and damage.

- Measure the inside diameter of the main bearing insert (**Figure 6-60, (1)**) in the crankcase cover. See *Crankshaft* on page 6-8 for the service limit. Record the measurements.

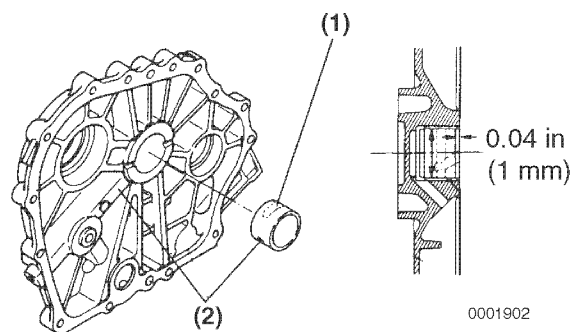

Figure 6-60

- If the measurements are not within specifications, replace the bearing insert.
 - Remove the bearing insert using an appropriate tool.
 - When installing the new bearing insert, make sure the oil groove (**Figure 6-60, (1)**) is facing up and that the oil hole is facing the oil port (**Figure 6-60, (2)**). Install to a depth of 0.04 in. (1 mm) from the thrust surface (**Figure 6-60**).

Camshaft and Tappet

Camshaft

1. Measure the installed depth (**Figure 6-61, (1)**) of the camshaft needle bearing on the cylinder block side. Record the measurement.

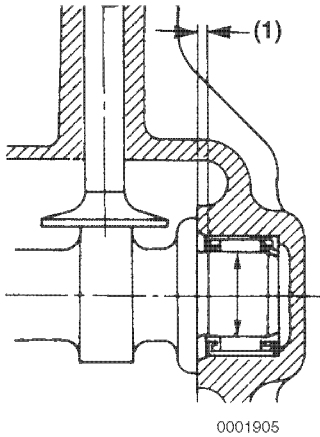

Figure 6-61

2. Visually inspect the needle bearing for evidence of wear or corrosion. Replace if damaged.
3. Press the new needle bearing to a depth of 0.055 - 0.059 in. (1.4 - 1.5 mm) (**Figure 6-61, (1)**).
4. Measure the camshaft bearing bore diameter in the crankcase cover. See *Camshaft on page 6-14* for the service limit. Record the measurement. The bearing surface is machined directly into the crankcase cover. If the bore is not within specification, the entire crankcase cover must be replaced.
5. Measure the camshaft journal outer diameter at each end. Record the measurements. Inspect the journal surfaces for damage or roughness. Replace the camshaft if it is damaged or not within specifications. See *Camshaft on page 6-14* for the service limit.

Tappet

1. Inspect the tappet contact surfaces for abnormal wear (**Figure 6-62, (1)**). Normal wear will be even as shown in (**Figure 6-62, (2)**). Slight surface defects can be corrected using an oilstone.

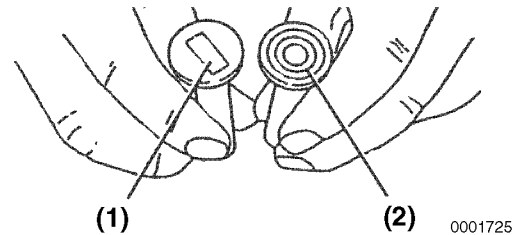

Figure 6-62

2. Measure the outside diameter of the tappet stem (**Figure 6-63, (1)**). See *Tappet on page 6-14* for the service limit.

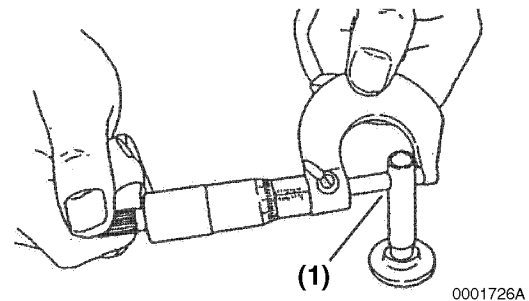

Figure 6-63

3. Measure the tappet bores in the cylinder block. See *Tappet on page 6-14* for the service limit. Record the measurements.

Balancer Shaft

Check the balancer shaft for wear or damage to the gear (**Figure 6-64, (1)**). Measure and inspect the bearing support ends (**Figure 6-64, (2)**) of the balancer shaft and bearings for wear and damage. Replace the balancer shaft and bearings if specifications are not within limits or damage is evident. See *Balancer Shaft on page 6-9* for the service limit.

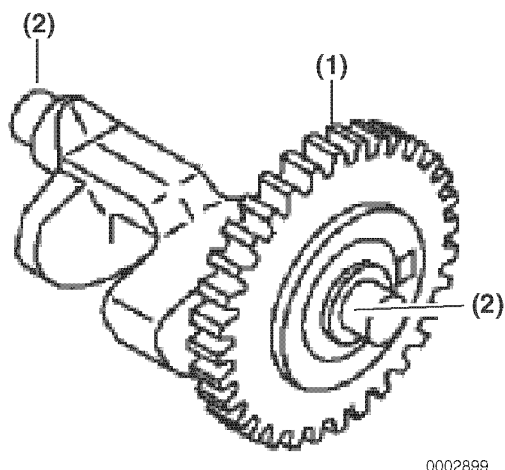

Figure 6-64

Timing Gears

Check the cam gear (**Figure 6-65, (1)**), the oil pump / governor drive gear (**Figure 6-65, (2)**), the crankshaft gear (**Figure 6-65, (3)**) and the balancer gear (**Figure 6-65, (4)**) for damage or wear. Replace any that are damaged or worn.

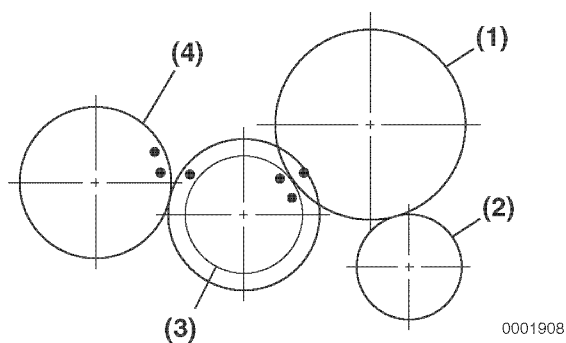

Figure 6-65

Cylinder Bore

The cylinder sleeve is cast into the aluminum cylinder block and is not replaceable. If it is damaged or worn beyond specifications, it can be bored oversize and an oversized piston and piston rings can be installed. See the parts catalog for available oversized parts.

1. Ensure that oil passages are clear and unobstructed.
2. Check for discoloration or evidence of cracks. If a fracture is suspected, use the colorcheck method or the MAGNAFLUX method to determine if the cylinder block is fractured.
3. Inspect the cylinder for roundness, taper or evidence of scoring. Collect and record the measurements. Consider honing, re-boring or replacing the cylinder block if the measurements are not within specification.
 - Take measurements at three places (**Figure 6-66, (a, b, c)**) and in two directions (**Figure 6-66, (d, e)**) in each cylinder. See *Cylinder Block on page 6-15* for the service limit. Record the measurements.

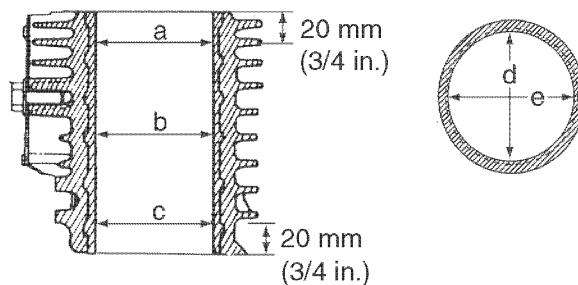

Figure 6-66

ENGINE

Honing and Boring

The piston must move freely in the cylinder while maintaining adequate compression and oil sealing. If the cylinder walls are scuffed, scored, out-of-round, or tapered beyond specifications, rebore and hone to restore cylinder to usable condition. Slight imperfections can be corrected by honing alone.

1. **Boring** - Significant cylinder damage may be corrected by boring the cylinder to an oversize dimension. Refer to the appropriate parts catalog for available oversize pistons and piston rings.
 - Boring a cylinder should always be done in a properly equipped machine shop.
 - A bored cylinder should always be finished with a hone to properly prepare the cylinder surface so the new piston rings will seat properly.
 - After the cylinder has been bored and honed, install the appropriate oversize piston and piston rings.

2. **Honing** - Minor cylinder imperfections may be corrected by using a rigid cylinder hone (**Figure 6-68, (1)**). Be sure not to exceed the maximum cylinder bore specification.

Deglazing - A used cylinder that did not require boring or honing, should always be deglazed with a ball hone (**Figure 6-68, (2)**) before installing new piston rings. This will properly prepare the cylinder surface to allow new piston rings to seat properly.

Note: When honing a cylinder, with either a ridged hone or a ball hone (**Figure 6-67, (1)**), move the rotating hone up and down in the cylinder bore to accomplish a 30° to 40° crosshatch pattern (**Figure 6-67**). This will provide the ideal surface for the proper seating of new piston rings.

CAUTION

Do not allow the honing tool to operate in one position for any length of time. Damage to the cylinder wall will occur. Keep the tool in constant up-and-down motion.

0000090en

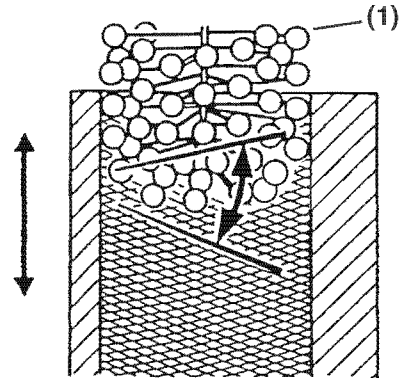

0000248A

Figure 6-67

- Use a 50:50 mixture of diesel fuel and engine oil as a honing fluid.
- Use a 300-grit hone at 300 - 1200 rpm (**Figure 6-68**).

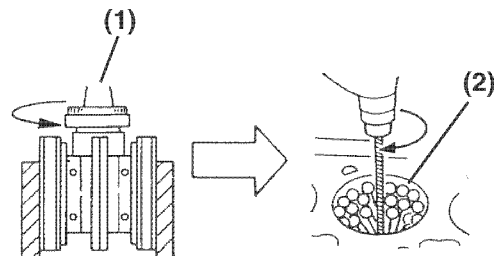

0000249B

Figure 6-68

IMPORTANT

Solvents will not adequately remove honing residue, resulting in premature piston and ring wear. Always wash cylinders using hot, soapy water.

- When honing is completed, wash the cylinder block with hot water and soap. The cylinder wall is adequately cleaned when a white rag wiped in cylinder comes out clean. Use brushes to clean all passages and crevices. Rinse with hot water and dry with compressed air. Apply clean engine oil to all steel surfaces to prevent rusting.

Inspection and Service of Engine Oil Pump

Disassembly and Inspection of Oil Pump

1. Remove and clean the oil filter (Figure 6-69, (6)). Inspect for damage. Do not remove the oil galley plugs (Figure 6-69, (7)) unless they show evidence of leakage or the associated oil passages require cleaning.
2. Remove the oil pump cover (Figure 6-69, (5)).

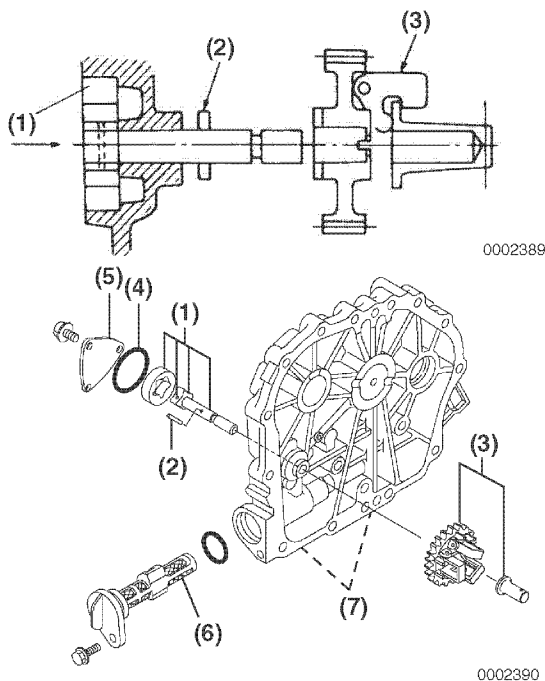

- 1 – Oil Pump Assembly
- 2 – Drive Pin
- 3 – Oil Pump / Governor Drive Gear and Spindle Assembly
- 4 – O-Ring
- 5 – Oil Pump Cover
- 6 – Oil Filter
- 7 – Plug (2 used)

Figure 6-69

3. Use a feeler gauge to measure the inner rotor-to-outer rotor clearance (Figure 6-70). Record the measurement.

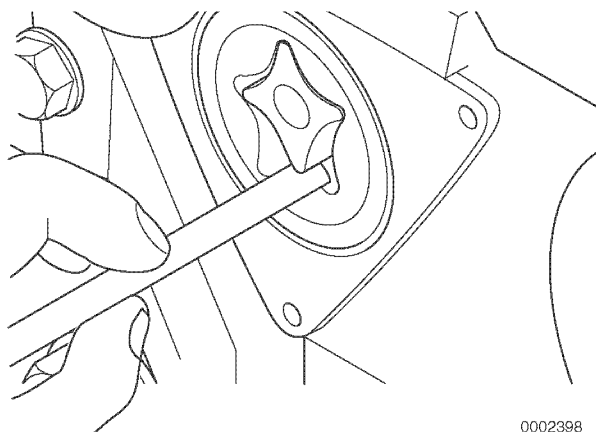

Figure 6-70

4. Use a feeler gauge to measure the outer rotor-to-housing clearance (Figure 6-71). Record the measurement.

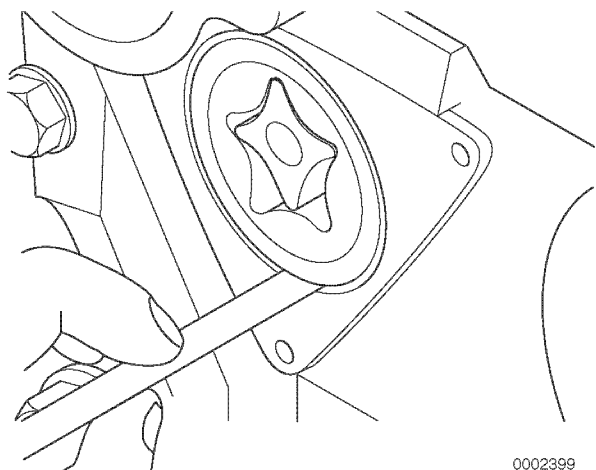

Figure 6-71

ENGINE

5. Measure the distance between the oil pump cover mounting surface and each rotor using a depth micrometer (**Figure 6-72**). Record the measurement.

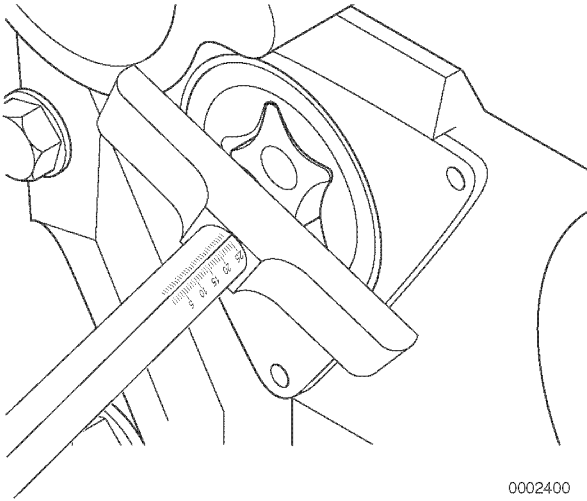

Figure 6-72

6. Use two screwdrivers to pry the oil pump / governor drive gear and spindle assembly (**Figure 6-73, (1)**) off from the oil pump shaft. Inspect the gear teeth and drive pin groove for wear or damage.
7. Remove the drive pin (**Figure 6-73, (2)**) from the oil pump shaft.

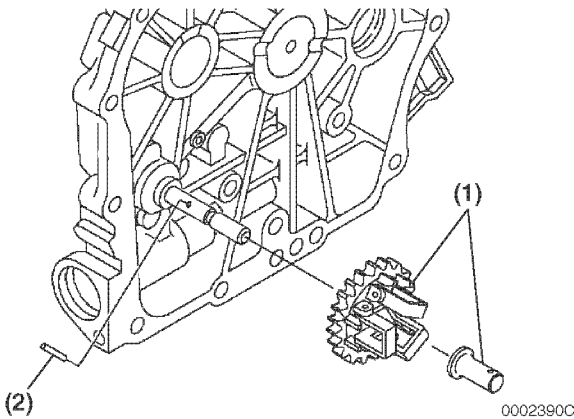

Figure 6-73

8. Remove the inner rotor, shaft assembly (**Figure 6-74, (1)**) and outer (**Figure 6-74, (2)**) rotor from the crankcase cover.

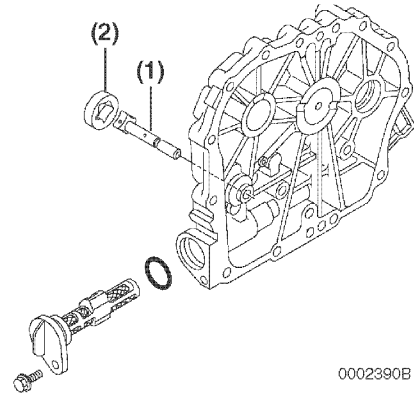

Figure 6-74

9. Inspect the pump cavity for deep scratches or excessive wear.
10. Measure the cavity inside diameter (**Figure 6-75, (1)**). Measure in at least two directions 90° apart. Record the measurements.
11. Measure the cavity depth (**Figure 6-75, (2)**) using a depth micrometer. Record the measurement.

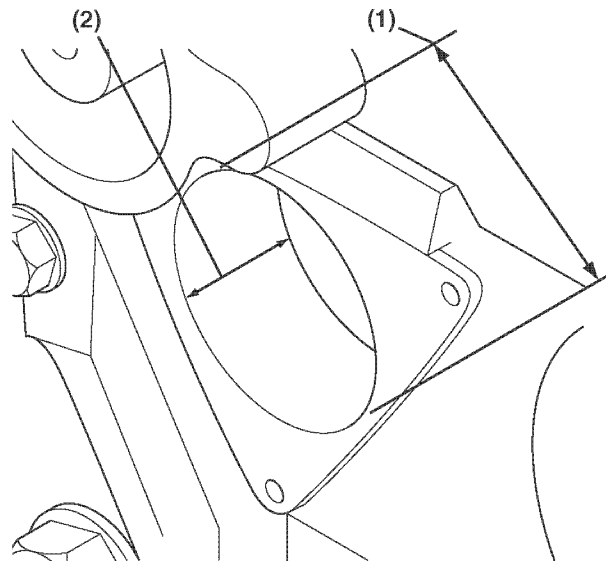

Figure 6-75

If any measurement is not within specification, replace all oil pump components, crankcase cover or both. See *Tappet* on page 6-14 and *Oil Pump (Trochoid Pump)* on page 6-17 for the service limits.

Reassembly of Oil Pump

1. Lubricate all components liberally with clean engine oil.
2. Install the inner rotor and shaft assembly (**Figure 6-76, (2)**). Install the outer rotor (**Figure 6-76, (1)**) with the dot on the rotor facing up.

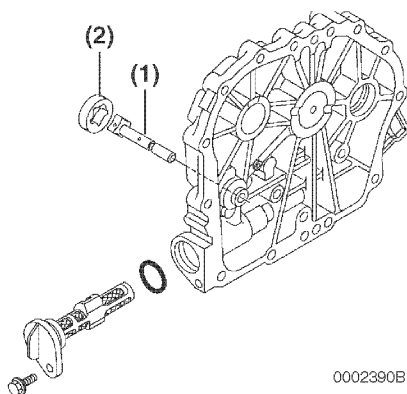

Figure 6-76

3. Install the drive pin (**Figure 6-77, (2)**). The pin must protrude evenly from either side of the shaft.

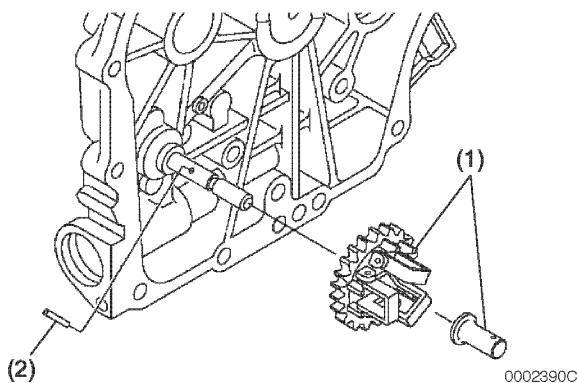

Figure 6-77

4. Install the oil pump cover and O-ring. Tighten to specification. See *Tightening Torques for Standard Bolts and Nuts* on page 4-18.

5. Install the oil pump / governor drive gear and spindle assembly (**Figure 6-77, (1)**) onto the oil pump shaft. Ensure the gear is fully seated and the drive pin engages the drive grooves in the gear.

Reassembly of Engine

Notes:

- Proceed slowly. Make no forced assemblies unless a pressing operation is indicated. All parts must be perfectly clean and lightly lubricated when assembled.
- Use new gaskets, seals and O-rings during assembly.
- Apply clean engine oil or assembly lube liberally to all internal parts during assembly.
- Tighten all fasteners to a given torque. If a special torque is not provided in the *Special Torque Specifications* on page 6-18, tighten to standard torque specifications. See *Tightening Torques for Standard Bolts and Nuts* on page 4-18.

ENGINE

Replacement of Throttle Shaft Seal - L48N Models

1. Remove the bolts (**Figure 6-78, (1)**) that retain the speed control assembly.

Note: Speed controls vary in design based on engine usage. See *Speed Control Device* on page 7-27 for more information.

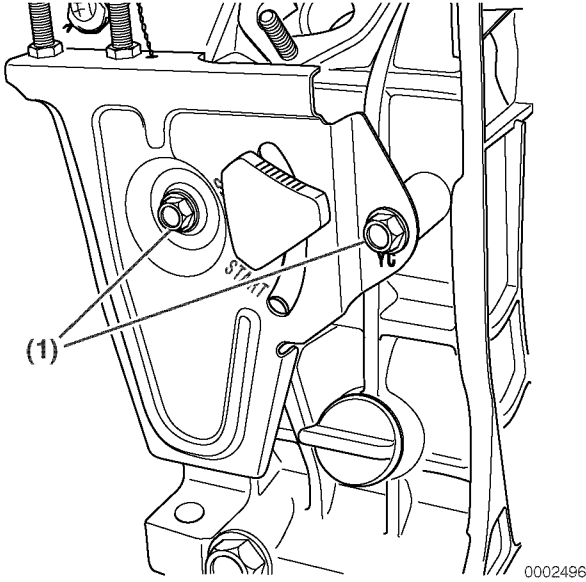

Figure 6-78

IMPORTANT

Note the position of the governor springs. Use care not to distort or stretch them.

2. Pull the assembly away from the crankcase (**Figure 6-79, (1)**) and mark the position of each spring end for reassembly. Carefully remove each spring.

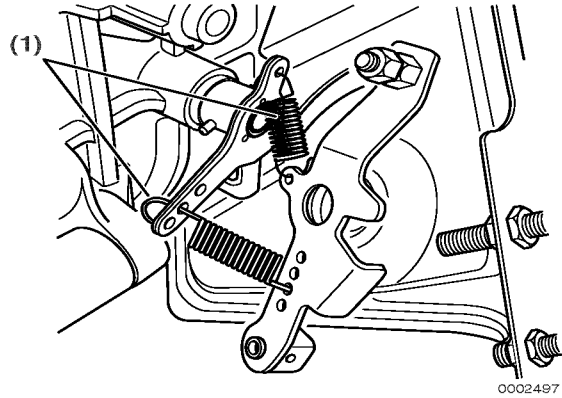

Figure 6-79

3. Remove the pin (**Figure 6-80, (1)**) fastening the speed control lever to the throttle shaft. The pin is tapered and must be driven out in the correct direction. Use a pin punch to drive the tapered pin out. Use square solid blows because the pin is held very tightly in the hole.

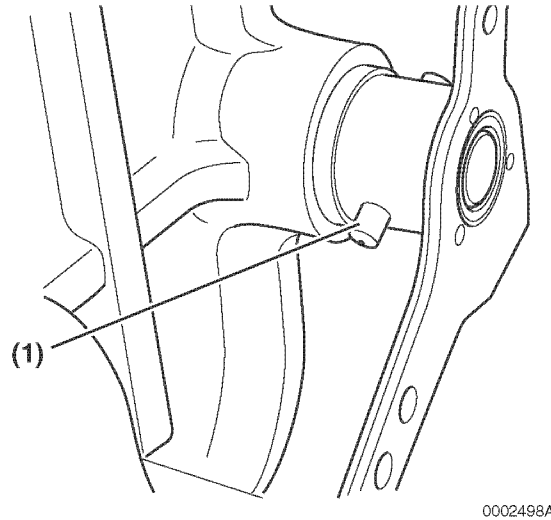

Figure 6-80

4. Remove the speed control lever and nylon washer.
5. Remove the throttle shaft and governor arm assembly (**Figure 6-81, (1)**) along with the washer (**Figure 6-81, (2)**).
6. Carefully pry the seal (**Figure 6-81, (3)**) out of the bore.

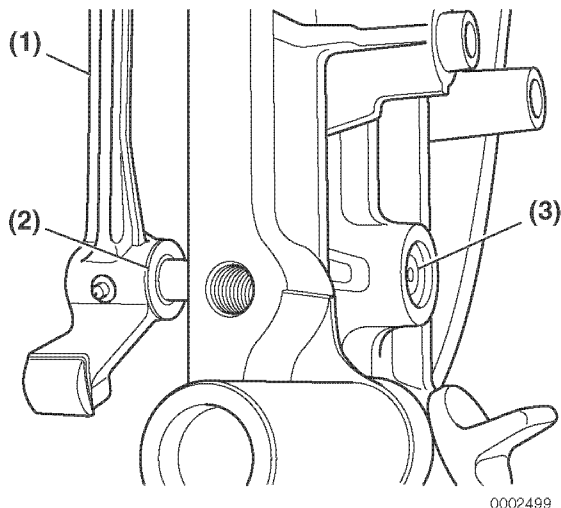

Figure 6-81

IMPORTANT

Damage or scratches on the throttle shaft can cause engine surging.

7. Inspect the throttle shaft for abnormal wear at the bearing area. Remove any burrs or scratches using fine emery cloth. Replace the throttle shaft and bearing if wear is excessive.
8. Install the new seal.
9. Reinstall the throttle shaft and governor lever assembly along with the washer.
10. Install the nylon washer and speed control lever on the throttle shaft.
11. Install the tapered pin in the opposite direction as it was removed. Use a pin punch to drive it securely into place.
12. Attach the governor springs in their original locations and install the speed control. See *Speed Control Device* on page 7-27 for more information.

Replacement of Throttle Shaft Seal - L70N and L100N Models

1. Remove the bolts (**Figure 6-82, (1)**) that retain the speed control assembly.

Note: Speed controls vary in design based on engine usage. See *Speed Control Device* on page 7-27 for more information.

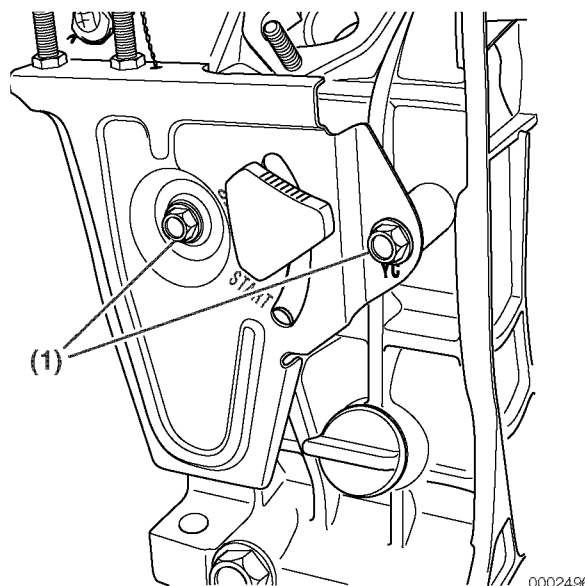

Figure 6-82

IMPORTANT

Note the position of the governor springs. Use care not to distort or stretch them.

ENGINE

2. Pull the assembly away from the crankcase (**Figure 6-83, (1)**) and mark the position of each spring end for reassembly. Carefully remove each spring.

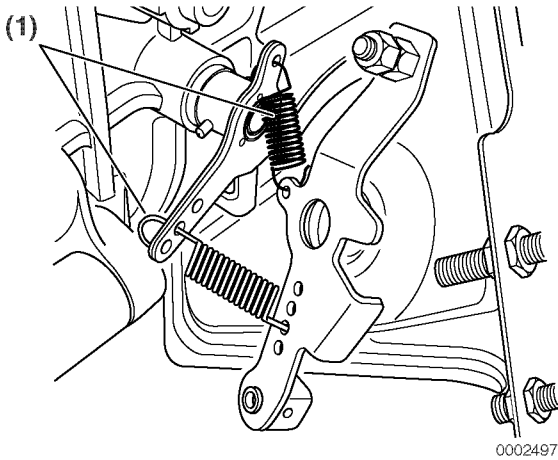

Figure 6-83

3. Remove the tapered pin (**Figure 6-84, (1)**) that fastens the governor lever to the throttle shaft using the special throttle shaft pin removal tool (**Figure 6-84, (2)**). See *Special Service Tools* on page 6-20 for the appropriate tool number.
4. Position the pin removal tool on the throttle shaft as shown (**Figure 6-84**).

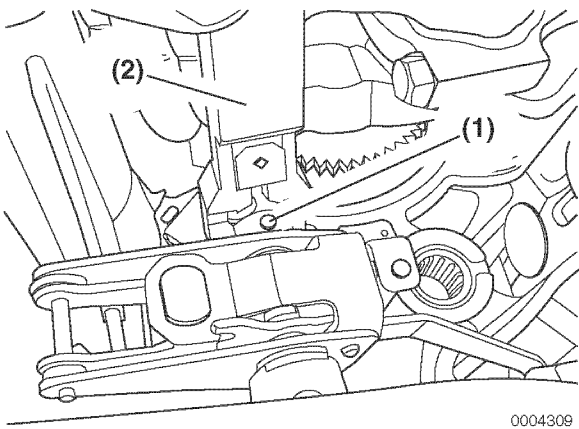

Figure 6-84

5. Tighten the hex cap screw (**Figure 6-85, (1)**) on top of the tool to push the pin through the governor lever and throttle shaft to remove the pin.

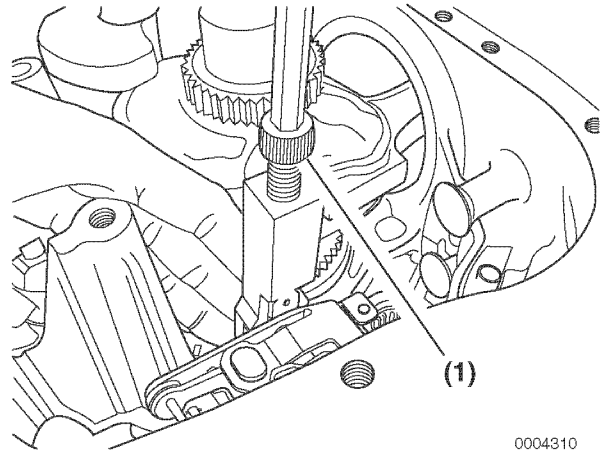

Figure 6-85

6. Remove the speed control lever, thrust washer, throttle shaft, inner washer and governor lever from the crankcase.
7. Carefully pry the seal (**Figure 6-86, (1)**) out of the bore.

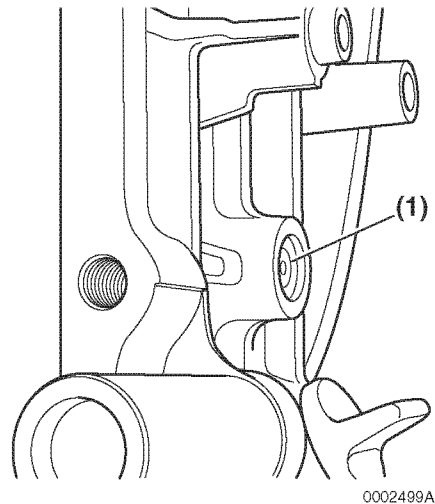

Figure 6-86

IMPORTANT

Damage or scratches on the throttle shaft can cause engine surging.

8. Inspect the throttle shaft for abnormal wear at the bearing area. Remove any burrs or scratches using fine emery cloth. Replace the throttle shaft and bearing if wear is excessive.
9. Install the new seal.
10. Reinstall the speed control lever, thrust washer and throttle shaft through the crankcase inner washer and governor lever.
11. Install the tapered pin in the opposite direction as it was removed. Use a pin punch to drive it securely into place.
12. Attach the governor springs in their original locations and install the speed control. See *Speed Control Device* on page 7-27 for more information.

Replacement of Crankshaft Seals

1. Remove the seals from the crankcase and crankcase cover using an appropriate tool. Use care not to scratch or damage the seal mounting bores.
2. Use a seal installation tool to install the crankshaft oil seal (**Figure 6-87, (4)**) into the crankcase cover (**Figure 6-87, (3)**). Install to a depth of 0.16 in. (4.0 mm) (**Figure 6-87, (5)**) below the end of the crankcase bore. See *Special Service Tools* on page 6-20 for the appropriate tool number.
3. Install the crankshaft oil seal (**Figure 6-87, (2)**) into the cylinder block flush with the surface of the cylinder block (**Figure 6-87, (1)**).

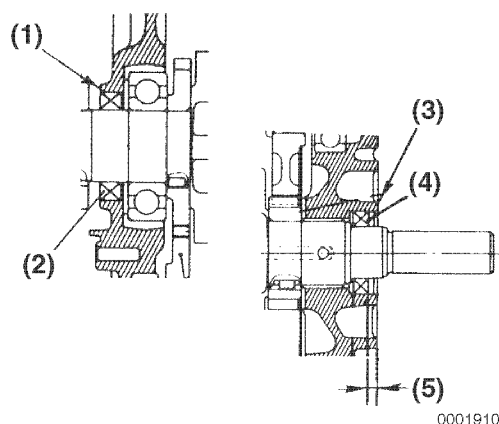

Figure 6-87

ENGINE

Reassembly of Piston, Piston Rings and Connection Rod

IMPORTANT

The piston and connecting rod must be assembled with the correct orientation. When correctly assembled, the identification mark (**Figure 6-88, (1)**) stamped into the top of the piston will be facing the same direction as the embossed mark (**Figure 6-88, (2)**) cast into the beam of connecting rod and the valve reliefs (**Figure 6-88, (4)**) in the top of the piston will be facing in the same direction as the matching marks (**Figure 6-88, (3)**) on the connecting rod and connecting rod cap.

Note: The actual appearance of the match marks will vary but they will always be in the same locations (**Figure 6-88**).

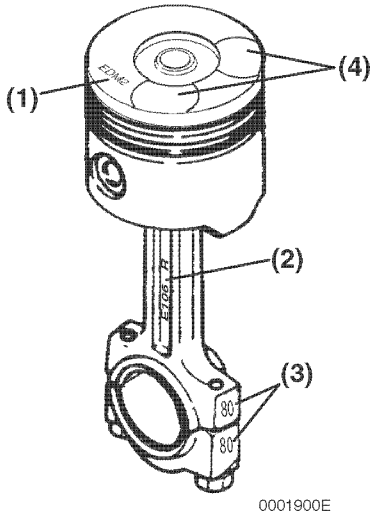

0001900E
Figure 6-88

1. If removed, install a new wrist pin bushing in the connecting rod using a press and the appropriate tool.

WARNING	
	
BURN HAZARD!	
<ul style="list-style-type: none">• Handle hot components with heat-resistant gloves.• Failure to comply could result in death or serious injury.	
<small>0000110en</small>	

IMPORTANT

Do not heat the piston directly with a flame.

Note: The wrist pin is a light press-fit. If the wrist pin is difficult to install, heat the piston in an oven or oil to 158° - 176°F (70° - 80°C).

2. Place the connecting rod into the piston. The identification mark (**Figure 6-89, (1)**) on the top of the piston and the embossed mark (**Figure 6-89, (2)**) on the beam of the connecting rod will be facing in the same direction.

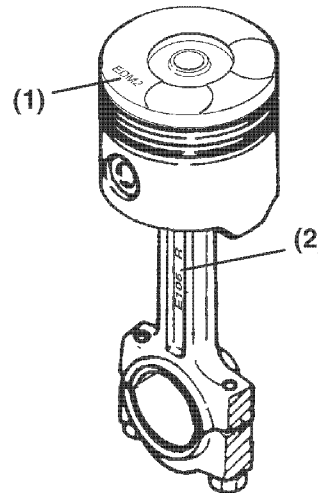

0001900C
Figure 6-89

3. Lubricate the wrist pin (**Figure 6-90, (4)**). Carefully support the piston (**Figure 6-90, (1)**) to prevent damage while driving the wrist pin into place. Use a suitable tool slightly smaller than the inside diameter of the wrist pin bore to drive the wrist pin. Drive the wrist pin through the piston and connecting rod (**Figure 6-90, (3)**) using a soft-faced hammer until it is centered between the circlip grooves in the wrist pin bore of the piston.
4. Install a circlip (**Figure 6-90, (2)**) into each of the circlip grooves in the wrist pin bore. Be sure that the circlips are fully expanded in the grooves.

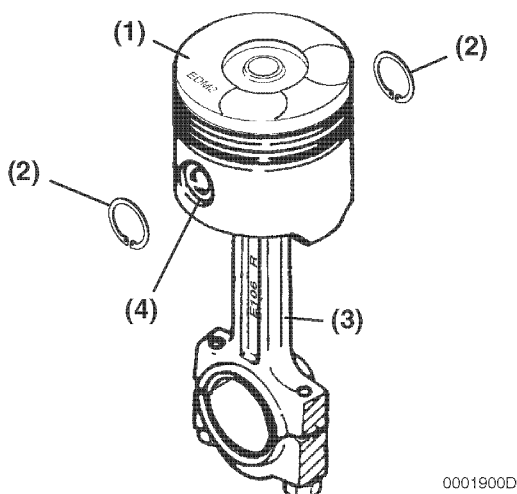

Figure 6-90

Installation of Piston Rings

Note: If installing new piston rings the end gap must be checked and adjusted as necessary. See *Piston, Piston Rings and Wrist Pin* on page 6-45. Use a piston ring end gap filing tool to adjust the piston ring end gap on new piston rings.

Note: The top and second piston rings must be installed with the stamped “makers mark” (**Figure 6-91, (1)**) facing the top of the piston. The “makers mark” may vary in appearance but will always be located on the top surface of the piston ring adjacent to the piston ring gap. The oil ring and oil ring expander can be installed either side up.

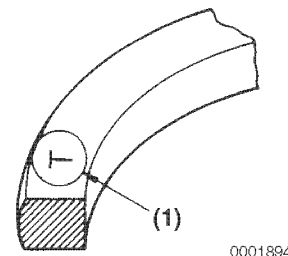

Figure 6-91

IMPORTANT

Always use a piston ring expander when installing piston rings. Never attempt to install piston rings by hand.

5. Install the oil ring expander (**Figure 6-92, (4)**) and oil ring (**Figure 6-92, (3)**) in the bottom piston ring groove. Install the oil ring with the end gap at 180° from the expander end gap.
6. Install the second compression ring (**Figure 6-92, (2)**) into the middle piston ring groove. This ring is identified by its dark color and tapered face profile.
7. Install the top compression ring (**Figure 6-92, (1)**) into the top piston ring groove. This ring is identified by its silver color and barrel-shaped face profile.

IMPORTANT

The oil ring expander (**Figure 6-92, (4)**) end gap must be located 180° from the oil ring (**Figure 6-92, (3)**) end gap.

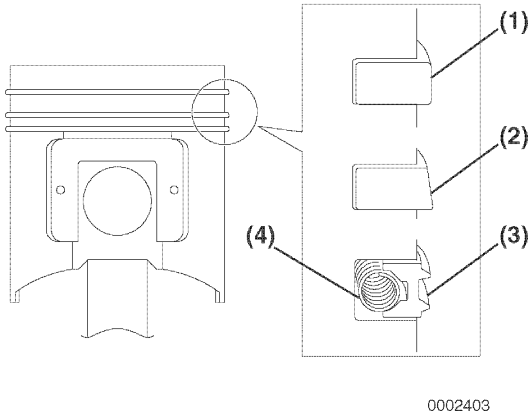

Figure 6-92

8. Stagger the piston ring end gaps at 120° intervals (**Figure 6-93, (1, 2, 3)**). Do not position the top piston ring end gap in line with the wrist pin.

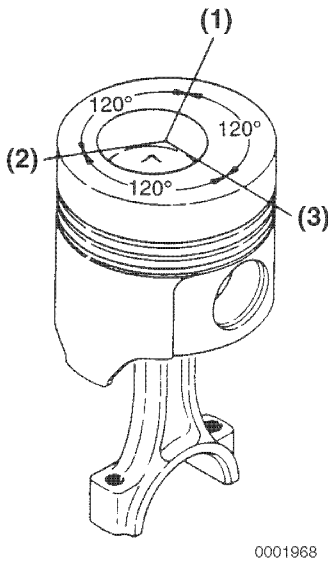

Figure 6-93

- 1 – Top Compression Ring End Gap
- 2 – Second Compression Ring End Gap
- 3 – Oil Ring End Gap

Installation of Crankshaft

1. Install the governor and speed control mechanism if it was removed. See *Replacement of Throttle Shaft Seal - L48N Models on page 6-56*.
2. Apply multi-purpose grease to the lip of the oil seal in the crankcase.
3. Apply oil or assembly lube to the crankshaft bearings and journals.
4. Secure the crankcase to the workbench.
5. Place the crankshaft into the crankcase, making sure the rear main bearing is “square” with the bearing pocket in the rear of the crankcase.
6. Hold the crankshaft in alignment and use a heavy, soft-faced hammer to drive into place.

Note: Begin slowly, using light hammer taps, to ensure that the crankshaft bearing is properly aligned with the bearing pocket and the bearing has begun to move into the bearing pocket.

7. Make sure the crankshaft is inserted completely into the crankcase and the main bearing is fully seated. Rotate the crankshaft to make sure it rotates freely.

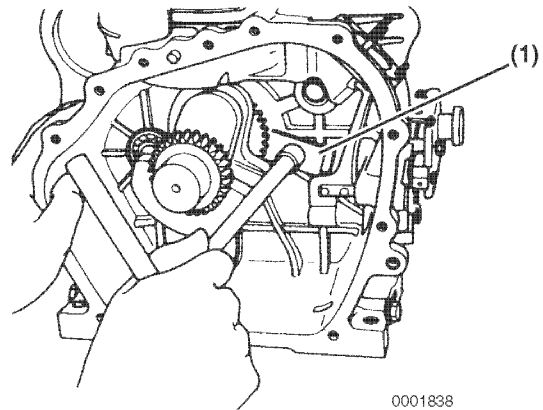

Figure 6-94

8. Position the bearing retainer plate (**Figure 6-94, (1)**) in the crankcase.
9. Tighten the bearing retainer plate bolt.

Installation of Piston and Connecting Rod

1. Make sure connecting rod surface is clean and dry before installing the bearing inserts in the connecting rod and cap.
2. Lubricate the piston, piston rings and cylinder bore with clean engine oil or assembly lubricant.
3. Rotate the crankshaft so the crankpin for the piston is near BDC (Bottom Dead Center).

IMPORTANT

Ensure the piston ring gaps are positioned correctly as shown in **(Figure 6-95)**.

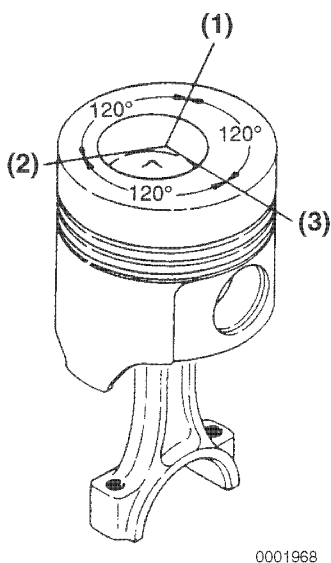

- 1 – Top Compression Ring End Gap
- 2 – Second Compression Ring End Gap
- 3 – Oil Ring End Gap

Figure 6-95

4. Use a piston ring compressor to compress the piston rings.

IMPORTANT

The piston and connecting rod must be installed with the correct orientation. When installed correctly, the identification mark **(Figure 6-96, (1))** stamped into the top of the piston will face the open side of the crankcase. The connecting rod match marks **(Figure 6-96, (3))** and the piston valve pockets will face the injection pump side of the engine.

IMPORTANT

Do not allow the connecting rod to contact the crankshaft journal during piston installation. Damage to the crankshaft bearing journal may result.

5. Carefully install the piston and rod assembly. The identification marks stamped into the top of the piston **(Figure 6-96, (1))** and connecting rod beam **(Figure 6-96, (2))** will be facing the open side of the crankcase. The connecting rod match marks **(Figure 6-96, (3))** and the piston valve pockets **(Figure 6-96, (4))** will face the injection pump side of the engine.

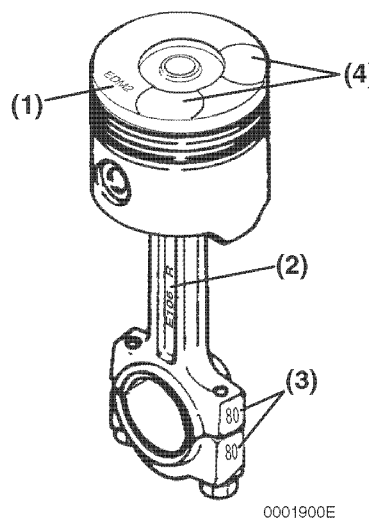

Figure 6-96

6. Apply a liberal coat of clean engine oil to the bearing inserts and crankshaft journal.

ENGINE

7. Apply a light coat of clean engine oil to the rod cap bolts. Install the connecting rod cap. Tighten the connecting rod bolts **Figure 6-97** to the specified torque in two stages as shown in chart below. See *Special Torque Specifications on page 6-18* for specifications.

First Step	1/2 of final torque
Second Step	Final torque

8. Rotate the crankshaft to make sure all components move freely.

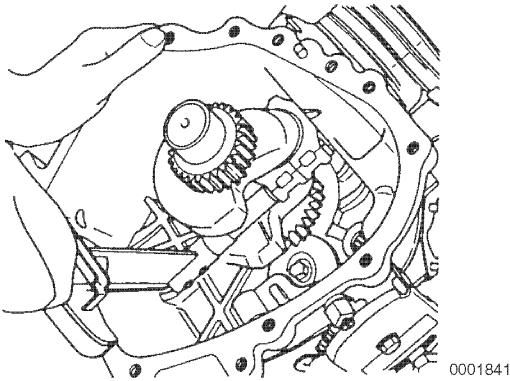

Figure 6-97

Installation of Camshaft and Balancer Shaft

1. Position the engine so the open crankcase is facing up.
2. Rotate the crankshaft to approximately 45° ATDC (After Top Dead Center).
3. Lubricate the balancer shaft bearings. Insert the balancer shaft **Figure 6-98** into the cylinder block.

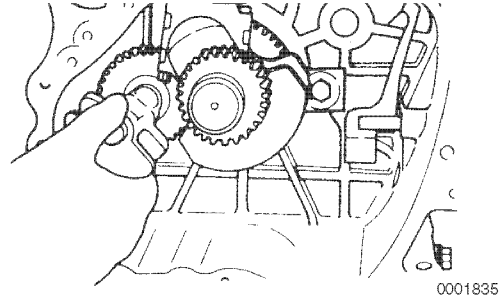
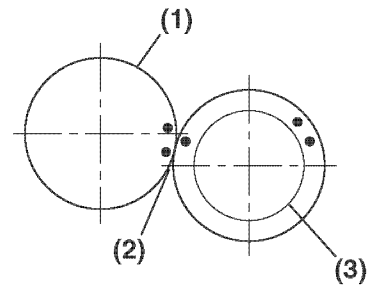

Figure 6-98

4. Align the timing marks (**Figure 6-99, (2)**) on the balancer shaft gear (**Figure 6-99, (1)**) and crankshaft gear (**Figure 6-99, (3)**) as the balancer shaft is being installed.



- 1 – Balancer Shaft and Gear
- 2 – Balancer to Crankshaft Timing Mark
- 3 – Crankshaft Gear

Figure 6-99

5. Lubricate the tappets. Position the cylinder block so that gravity will keep the tappets in place and away from the camshaft lobes when the camshaft is reinstalled. Install the tappets in their respective locations in the cylinder block and push them fully into the tappet bores.
6. Rotate the crankshaft to approximately TDC (Top Dead Center).
7. Lubricate the camshaft needle bearing in the cylinder block. Slowly insert the camshaft **Figure 6-100** into the cylinder block.

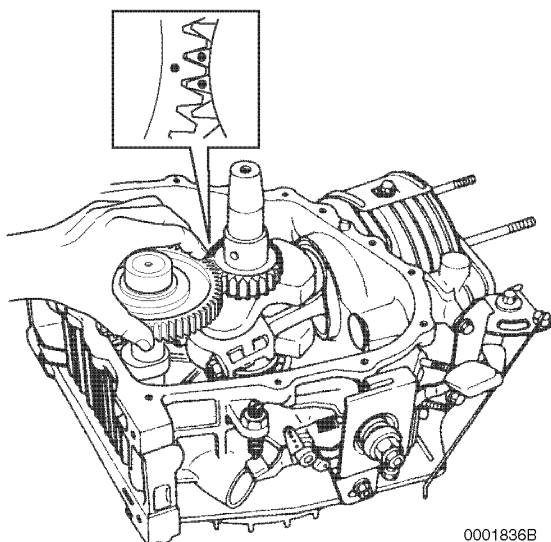
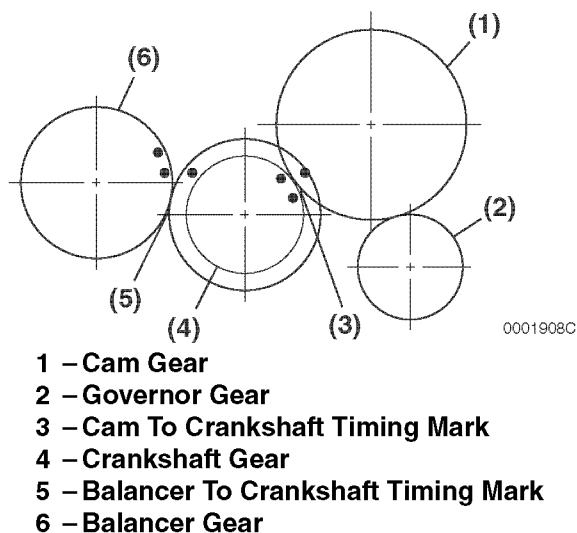

Figure 6-100

8. Align the timing marks (**Figure 6-101, (3)**) on the camshaft gear and crankshaft gear as the camshaft is being installed.

Note: Balancer shaft gear marks (**Figure 6-101, (5)**) and camshaft gear marks will not align at the same time with crankshaft gear marks as shown in (**Figure 6-101**). The balancer shaft gear and camshaft gear marks must match to crankshaft gear marks independently.

9. Rotate crankshaft to ensure crankshaft timing marks align **Figure 6-101** to the balancer shaft and camshaft marks independently.



- 1 – Cam Gear
- 2 – Governor Gear
- 3 – Cam To Crankshaft Timing Mark
- 4 – Crankshaft Gear
- 5 – Balancer To Crankshaft Timing Mark
- 6 – Balancer Gear

Figure 6-101

Installation of Crankcase Cover

1. Inspect oil pump assembly and service as needed, if not already completed.
1. Place a new aluminum gasket between the mating surfaces of the crankcase and the crankcase cover. Align gasket properly over two alignment pins on crankcase surface.
2. Apply multi-purpose grease to the lip of the oil seal in the crankcase cover.
3. Install an oil seal protector tool on the end of the crankshaft. See *Special Service Tools* on page 6-20 for the appropriate tool number.
4. Install the crankcase cover (**Figure 6-102, (1)**) while pushing down lightly on the crankcase cover. Slowly turn the flywheel to allow the governor / oil pump drive gear to mesh with the camshaft gear. Maintain the light pressure while “wiggling” the cover slightly to align the balancer shaft bearing and the camshaft bearing with their respective pockets in the underside of the cover until the cover drops into place.

5. Tighten the crankcase cover bolts to the specified torque in two stages (1/2 then full torque) in the sequence shown (**Figure 6-102**). See *Special Torque Specifications* on page 6-18.

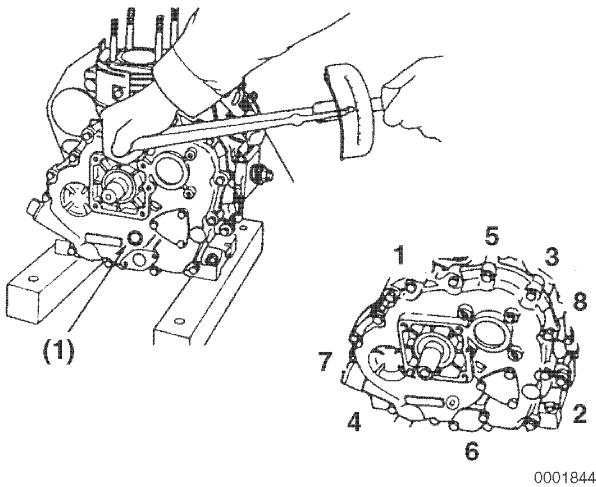

Figure 6-102

- Crankcase stiffener bolts are in the center of the crankcase on some model engines.
- Tighten the stiffener bolts after the bolts on the crankcase perimeter are tightened (**Figure 6-102**). See *Special Torque Specifications* on page 6-18.

Final Engine Assembly

1. Install the stator, lead retainer and flywheel. See *Installation of Stator* on page 9-17.
2. Rotate the flywheel/crankshaft to make sure all parts rotate freely.
3. Install the cylinder head assembly. See *Installation of Cylinder Head* on page 6-33.
4. Install the fuel injection pump. See *Installation of Fuel Injection Pump* on page 7-17.
5. Make sure the nozzle gasket and spacer are in position. Install the fuel injector, high pressure fuel injection line and return line. See *Installation of the Fuel Injector* on page 7-26.
6. Check actual piston TDC position. See *Checking Actual Piston TDC (Top Dead Center)* on page 6-36.
7. Check the fuel injection timing. See *Checking and Adjusting Fuel Injection Timing* on page 7-11.
8. Adjust valve clearance. See *Measuring and Adjusting Valve Clearance* on page 6-39.
9. Install the air intake manifold with a new gasket.
10. Install the starter pulley onto the flywheel.
11. Attach the rubber seal (**Figure 6-103, (1)**) to the fan housing.
12. Install the fan housing rubber supports (**Figure 6-103, (2)**) and sleeves (**Figure 6-103, (3)**).

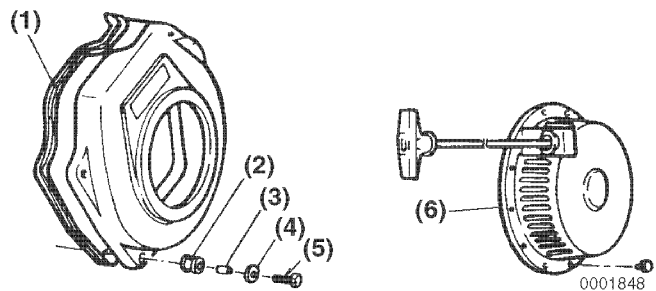

Figure 6-103

13. Install the cooling fan housing and secure with washers (**Figure 6-103, (4)**) and bolts (**Figure 6-103, (5)**). Install the recoil starter (**Figure 6-103, (6)**) if it has been removed.

14. Install the air cleaner assembly using a new filter element and gasket. See *Clean Air Cleaner Element* on page 5-29 for cleaning and installation procedures.
15. Install the starter motor (if equipped).
16. Install the exhaust muffler (**Figure 6-104**).

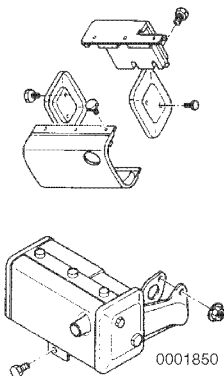

Figure 6-104

17. If equipped, install the fuel tank (**Figure 6-105**).
18. Connect the fuel supply lines to the fuel injection pump, and the fuel return lines from the injectors to the fuel tank.

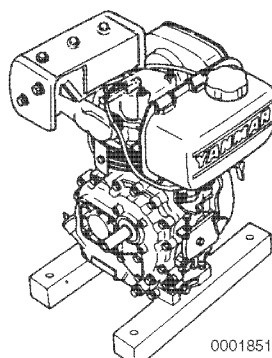

Figure 6-105

19. Use the recoil or electric starter to rotate the flywheel/crankshaft to make sure all parts rotate freely.

Installation of Engine

1. Secure the engine in the machine.
2. Connect the fuel supply and fuel return lines at the engine. Turn on any fuel valves.
3. Connect the throttle cable, any external engine shut-off linkage (if equipped) and any external compression release linkage.
4. Connect all electrical connectors.
5. Fill the crankcase with the appropriate engine oil.
6. Connect the battery cables at the battery. Always connect the positive (+) cable first.

This Page Intentionally Left Blank

Section 7



FUEL SYSTEM

	Page
Before You Begin Servicing	7-3
Introduction.....	7-4
Specifications	7-4
Test and Adjustment Specifications	7-4
Special Torque Specifications	7-4
Special Service Tools.....	7-5
Measuring Instruments.....	7-5
Fuel System Operation.....	7-6
Fuel Injection Pump.....	7-7
Fuel Injector.....	7-8
Fuel System Diagram.....	7-9
Fuel System Components.....	7-10
Checking and Adjusting Fuel Injection Timing	7-11
Checking Fuel Injection Timing	7-11
Adjusting Fuel Injection Timing.....	7-14
Fuel Injection Pump.....	7-16
Removal of Fuel Injection Pump.....	7-16
Installation of Fuel Injection Pump.....	7-17
Replacement and/or Adjustment of the Fuel Limiter	7-18
Fuel Injector.....	7-22
Removal of Fuel Injector.....	7-22
Testing of Fuel Injector	7-23
Disassembly and Inspection of Fuel Injector.....	7-24
Adjusting Fuel Injector Pressure.....	7-25
Reassembly of Fuel Injector	7-26
Installation of the Fuel Injector.....	7-26
Speed Control Device	7-27
Variable Speed Type	7-28
Remote Control Type	7-29
Variable Speed Friction Plate Type	7-30
Constant Speed Type.....	7-31

This Page Intentionally Left Blank

BEFORE YOU BEGIN SERVICING

Before performing any service procedures within this section, read the following safety information and review the *Safety* section on page 3-1.

 WARNING

<p>ENTANGLEMENT HAZARD!</p> <ul style="list-style-type: none"> • ALWAYS stop the engine before you begin to service it. • NEVER leave the key in the key switch when you are servicing the engine. Someone may accidentally start the engine and not realize you are servicing it. • Failure to comply could result in death or serious injury.
<small>0000010en</small>

 WARNING
<p>SUDDEN MOVEMENT HAZARD!</p> <ul style="list-style-type: none"> • ALWAYS allow the engine to warm-up for at least 5 minutes to allow the engine idle speed to return to normal before engaging the transmission or any PTO attachments. • NEVER engage the transmission or PTO at an elevated engine speed. • Failure to comply could result in death or serious injury.
<small>0000006en</small>

 WARNING

<p>FUME / BURN HAZARD!</p> <ul style="list-style-type: none"> • ALWAYS read and follow safety related precautions found on containers of hazardous substances like parts cleaners, primers, sealants and sealant removers. • Failure to comply could result in death or serious injury.
<small>0000014en</small>

CAUTION
<ul style="list-style-type: none"> • NEVER remove or attempt to remove the tamper-proof devices from the high-speed throttle limit screw. This adjustment has been made at the factory to meet all applicable emissions regulations and then sealed. • DO NOT attempt to remove or adjust the fuel limiter assembly. • NEVER attempt to make adjustments to any sealed adjustment screw. • Any alterations to this engine may affect the warranty coverage of this engine. • <i>See Yanmar Limited Warranty in Section 2.</i>
<small>0000174en</small>

FUEL SYSTEM

INTRODUCTION

This section of the *Service Manual* describes the procedures necessary to remove, install and time the fuel injection pump, fuel injector and the associated system components.

SPECIFICATIONS

Test and Adjustment Specifications

Fuel Injector Pressure	Fuel Injection Timing
2843 psi (19.6 MPa, 200 kgf/cm ²)	See <i>Checking and Adjusting Fuel Injection Timing</i> on page 7-11.

Note: Each 0.004 in. (0.1 mm) change in shim thickness in the fuel injector will result in approximately a 284 psi (1.96 MPa, 20 kgf/cm²) pressure change. See *Adjusting Fuel Injector Pressure* on page 7-25.

Special Torque Specifications

Component	Model	Thread Diameter and Pitch	Torque	Lubricating Oil Application (Thread Portion and Seat Surface)
Fuel Nozzle Case Nut	All Models	U-0.605-40UNS-2B	30 - 35 lb-ft (40.7 - 47.5 N·m, 4.2 - 4.8 kgf·m)	Not Applied
Fuel Pump Delivery Valve (If Equipped)		M14 x 15 mm	21.5 - 25 lb-ft (29.4 - 34.3 N·m, 3.0 - 3.5 kgf·m)	Not Applied
Fuel Injection Pump Nuts		3-M6 x 1.0 mm	87 - 104 lb-in. (9.8 - 11.8 N·m, 1.0 - 1.2 kgf·m)	Not Applied
Fuel Injection Nozzle Nuts		2-M6 x 1.0 mm	61.3 - 79 lb-in. (6.9 - 8.9 N·m, 0.7 - 0.9 kgf·m)	Not Applied
Fuel Injection Pump Inspection Window Plate Nuts		3-M6x1.0 mm	87 - 104 lb-in. (9.8 - 11.8 N·m, 1.0 - 1.2 kgf·m)	Not Applied
Fuel Limiter Mounting Nut		-	215 - 218 lb-in. (24.2 - 24.6 N·m, 2.4 - 2.5 kgf·m)	Not Applied
High Pressure Fuel Injection Line Nuts		-	19.8 - 23.5 lb-ft (26.9 - 31.9 N·m, 2.7 - 3.3 kgf·m)	Not Applied

See *Tightening Torques for Standard Bolts and Nuts* on page 4-18, for standard hardware torque values.

SPECIAL SERVICE TOOLS

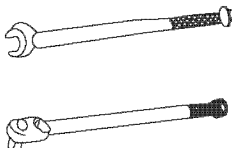
No.	Tool Name	Application	Illustration
1	Torque Wrench (Available Locally)	For tightening nuts and bolts to the specified torque	 0000840

MEASURING INSTRUMENTS

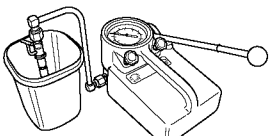
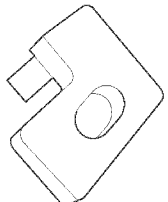
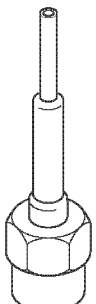
No.	Instrument Name		Application	Illustration
1	Fuel Injector Tester (Available Locally)		For observing injection spray pattern of fuel injection nozzle and measuring injection pressure	
2	Fuel Adjustment Jig (Yanmar P/N 114771-92310)		Used to adjust fuel injection timing and fuel limiter.	 0004596
3	Spill-Timing Tool*	Locally Fabricated	Used to set fuel injection timing	

* Make from a short piece of the end of a high-pressure fuel injection line, a high-pressure fuel injection line nut, and a short piece of clear plastic tubing (a thin nozzle from an aerosol spray can works well). Drill out the end of the fuel line to accept the nozzle. Use a small amount of silicone sealant to seal the nozzle into the fuel line.

FUEL SYSTEM OPERATION

The following describes the operation of the fuel injection pump and fuel injector.

CAUTION

- **NEVER** remove or attempt to remove the tamper-proof devices from the high-speed throttle limit screw. This adjustment has been made at the factory to meet all applicable emissions regulations and then sealed.
- **DO NOT** attempt to remove or adjust the fuel limiter assembly.
- **NEVER** attempt to make adjustments to any sealed adjustment screw.
- Any alterations to this engine may affect the warranty coverage of this engine.
- *See Yanmar Limited Warranty in Section 2.*

0000174en

Fuel Injection Pump

Note: Parts breakdown is for reference only.

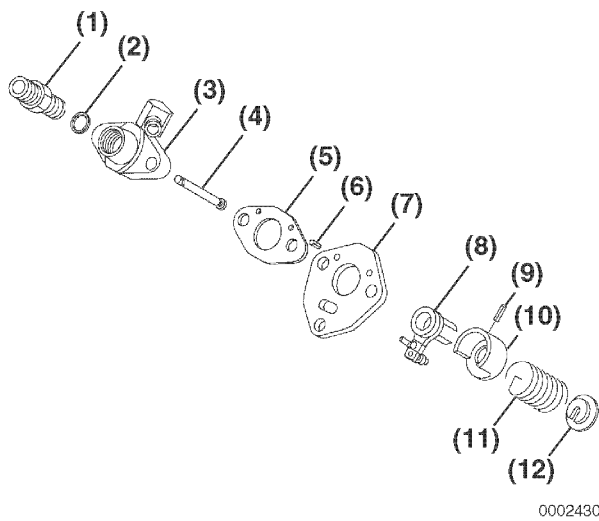

- 1 – Fuel Delivery Valve
- 2 – O-Ring
- 3 – Body
- 4 – Fuel Plunger
- 5 – Gasket
- 6 – Alignment Pin
- 7 – Base Plate
- 8 – Fuel Control Lever
- 9 – Pin
- 10 – Spring Seat
- 11 – Spring
- 12 – Spring Retainer

Figure 7-1

Note: While the parts catalog shows the individual service parts for the fuel injection pump, the fuel injection pump is not intended to be serviceable. Do not disassemble the fuel pump. If the fuel injection pump is faulty, replace it with a new fuel injection pump assembly.

The fuel injection pump is a very important component of the engine. It is capable of making very precise fuel delivery adjustments according to the varied loads applied to the engine.

The fuel delivery valve (**Figure 7-2, (5)**) connects to a high-pressure fuel injection line that is attached to the fuel injector. The plunger is activated by a tappet (**Figure 7-2, (6)**) that rides on a special lobe (**Figure 7-2, (7)**) of the camshaft. The shape of the fuel injection lobe prevents the engine from operating in the reverse direction. A spring (**Figure 7-2, (2)**) keeps the tappet in contact with the camshaft lobe. Proper fuel injection timing is adjusted by the thickness of a shim (**Figure 7-2, (8)**) installed between the fuel injection pump and the crankcase mounting surface.

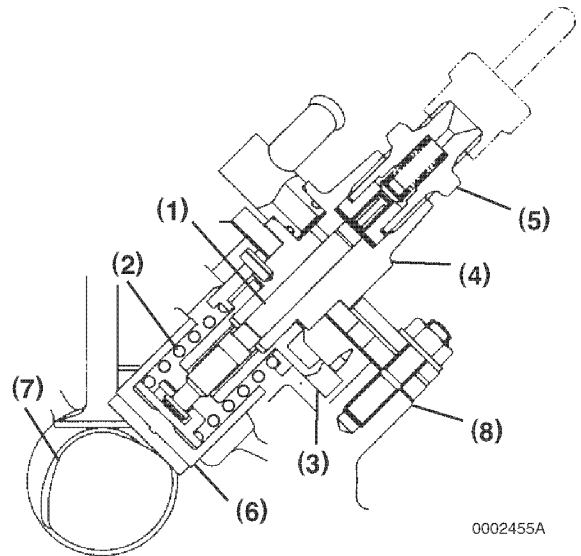
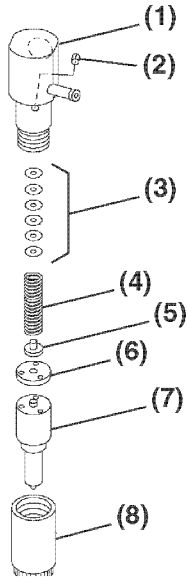

Figure 7-2

Fuel from the fuel tank to the fuel injection pump is delivered either by gravity or a low-pressure fuel pump. Engine speed is controlled by a centrifugally operated governor assembly that acts directly against the control lever (**Figure 7-2, (3)**).

Fuel to be injected into the cylinder is pressurized by the up and down motion of the camshaft-driven plunger (**Figure 7-2, (1)**) within the body (**Figure 7-2, (4)**), through the fuel supply valve, and is then supplied by the high-pressure fuel injection line to the fuel injector.

Fuel Injector



0002429

- 1 – Injector Body
- 2 – Alignment Pin
- 3 – Pressure Adjusting Shims
- 4 – Spring
- 5 – Spring Seat
- 6 – Valve Stop Spacer
- 7 – Nozzle Body and Valve
- 8 – Nozzle Case Nut

Figure 7-3

The fuel injector is essentially a spring-loaded valve. When fuel pressure from the fuel injection pump reaches a predetermined level, the pintle (valve) is forced off its seat and fuel is atomized as it passes between the pintle and seat. The timing and quantity of the fuel injected into the cylinder is controlled by the fuel injection pump and governor assembly.

FUEL SYSTEM DIAGRAM

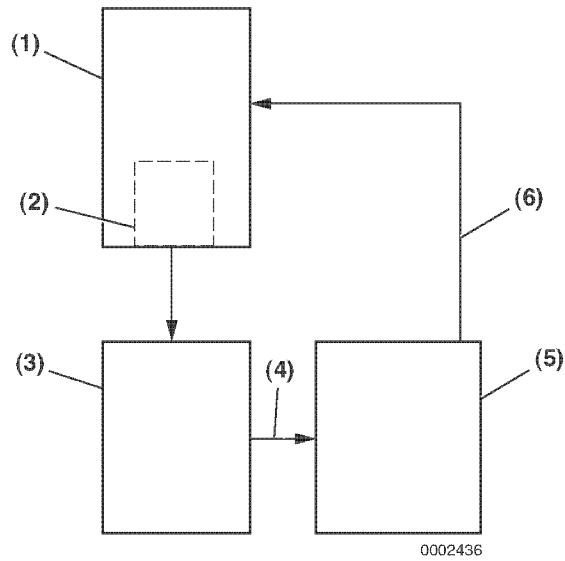

- 1 – Diesel Fuel Supply
- 2 – Fuel Filter
- 3 – Fuel Injection Pump

- 4 – High-Pressure Fuel Injection Line
- 5 – Fuel Injector
- 6 – Fuel Return from Fuel Injector

Figure 7-4

FUEL SYSTEM

FUEL SYSTEM COMPONENTS

Typical (Components may vary by engine model and engine application)

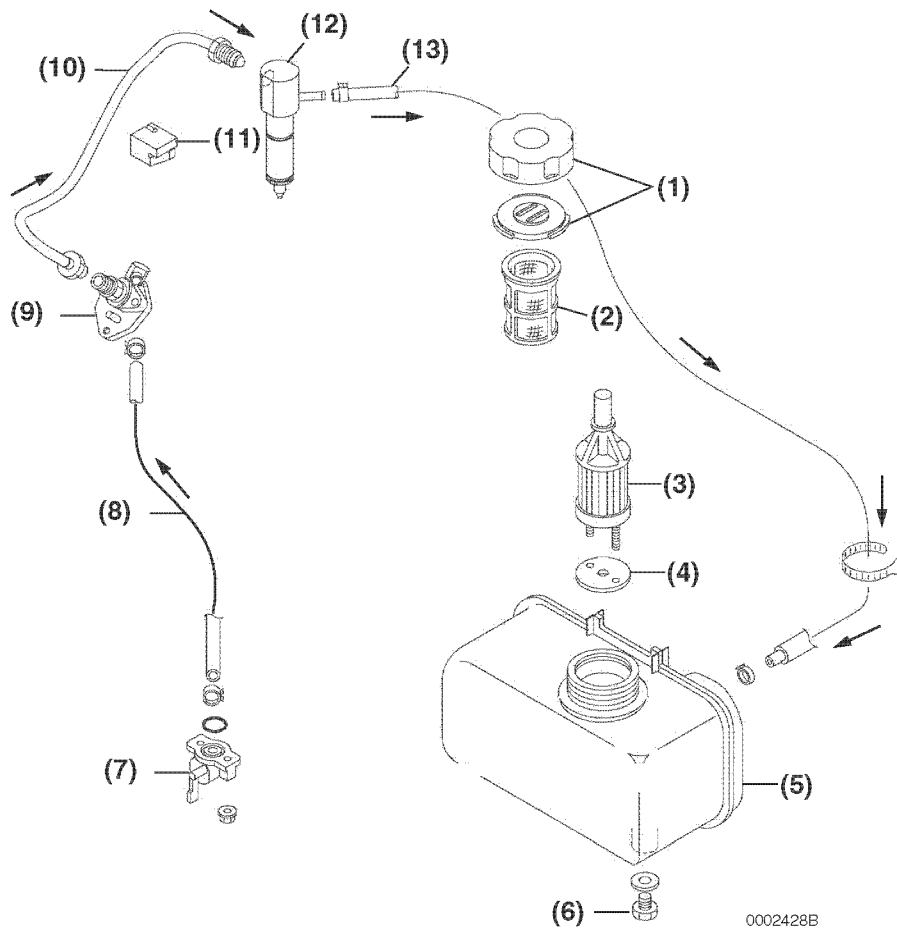

- 1 – Fuel Filler Cap and Gasket
- 2 – Fuel Filler Strainer
- 3 – Fuel Filter
- 4 – Fuel Filter Gasket
- 5 – Fuel Tank (Typical)
- 6 – Drain Plug
- 7 – Fuel Shut-Off Valve

- 8 – Fuel Supply Line
- 9 – Fuel Injection Pump
- 10 – High-Pressure Fuel Injection Line
- 11 – Fuel Injection Line Support
- 12 – Fuel Injector
- 13 – Return Fuel Hose

Figure 7-5

CHECKING AND ADJUSTING FUEL INJECTION TIMING

Checking Fuel Injection Timing

Note: Some fuel may drain from the fuel injection pump during this process. Make provisions to contain spills.

1. Verify actual piston TDC. See *Checking Actual Piston TDC (Top Dead Center)* on page 6-36.
2. Ensure the fuel injection pump is primed with fuel. See *Priming the Fuel System* on page 4-12.

Note: If the engine is removed from the equipment, attach a “temporary” fuel supply to the fuel injection pump inlet.

3. Remove the cooling fan housing and recoil starter.
4. Highlight the TDC timing mark on the cylinder cooling fin (**Figure 7-6, (1)**).
5. Highlight the TDC (Top Dead Center) (**Figure 7-6, (2)**) and target timing (**Figure 7-6, (3)**) marks BTDC (Before Top Dead Center) on the flywheel timing grid (**Figure 7-7**) based on the Fuel Injection Timing Chart (**Figure 7-8**).

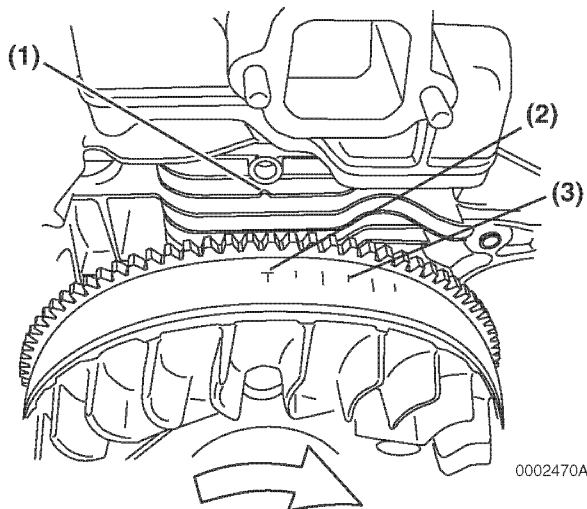

Figure 7-6

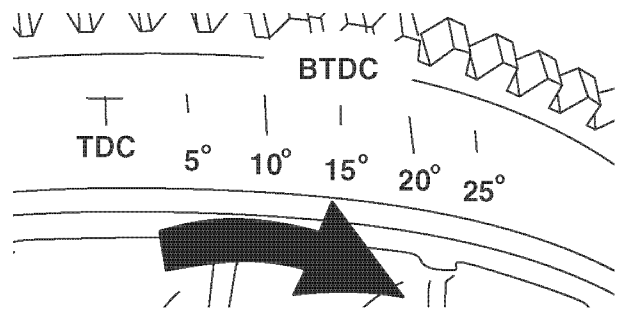

Figure 7-7

Fuel Injection Timing Chart

Engine	Injection Timing BTDC
L48N	16.5 ± 1.0°
L70N	13.0 ± 1.0°
L100N	13.0 ± 1.0°

Figure 7-8

6. Clean the areas around the fuel injection pump and fuel injector to prevent contamination when the fuel injection line is removed.

IMPORTANT

Always use a wrench to hold the fuel injection pump fuel delivery valve to prevent loosening of the delivery valve when loosening or tightening the high-pressure fuel injection lines.

Note: To prevent “rounding” the fuel line nuts always use a “line” or “flare nut” wrench.

7. Remove the high-pressure fuel injection line.
8. Set the throttle control lever to the minimum speed position.
9. Remove the nut (**Figure 7-9, (2)**) fastening the injection pump inspection window cover plate (**Figure 7-10, (1)**). Remove the inspection cover plate and gasket.

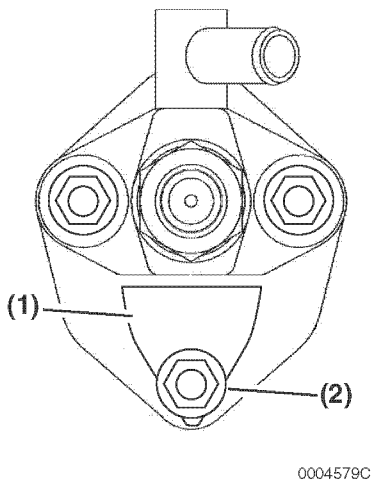

Figure 7-9

10. Install the fuel adjustment jig (**Figure 7-10, (2)**), Yanmar P/N 114771-92310, in the fuel injection pump inspection window. Using the inspection window cover plate nut, fasten the fuel adjustment jig aligning the upper left edge of the jig (**Figure 7-10, (4)**) to the alignment mark scribed on the face of the fuel injection pump (**Figure 7-10, (1)**) base plate (**Figure 7-10, (3)**).

Note: Be sure to keep the fuel adjustment jig parallel to the inspection window opening. (**Figure 7-10** shows the alignment mark for clarity only. The edge of the jig should be directly on the mark when installed properly.)

To assist in the alignment of the fuel adjustment jig, tighten the attaching nut to just hold the jig "lightly" in place. Then "lightly" tap the jig into the proper position. Once the jig is in position, tighten the attaching nut to hold the jig firmly in place.

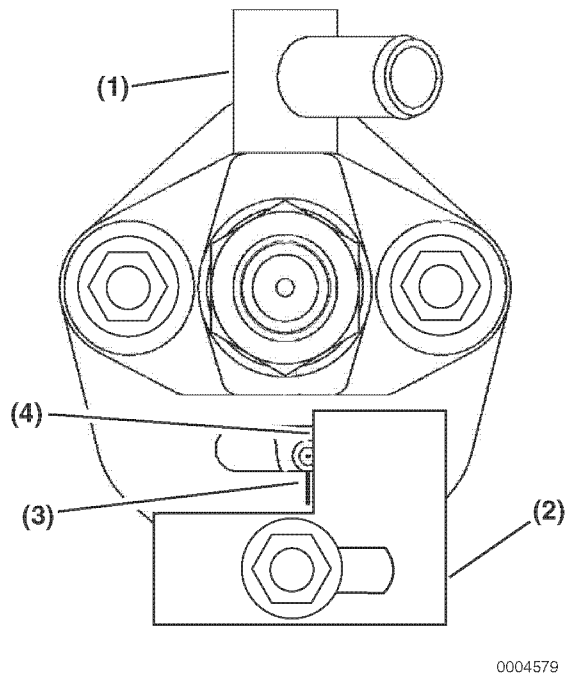

Figure 7-10

11. Set the throttle control lever to the maximum speed position.
12. Install the spill-timing tool (**Figure 7-11, (1)**) onto the fuel delivery valve. See *Measuring Instruments on page 7-5*, for a description of the tool.

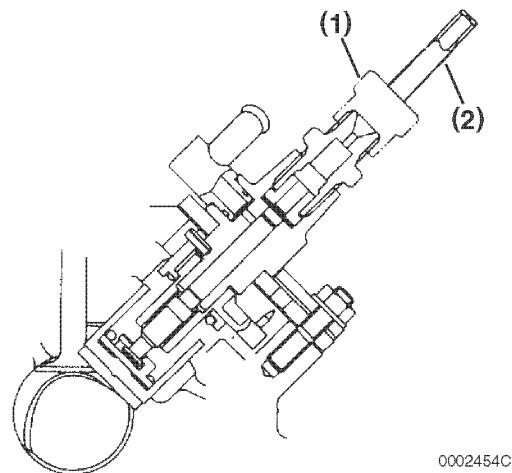

Figure 7-11

Note: If a timing tool is not available, timing can be checked by watching the fuel level movement in the delivery valve outlet.

13. Turn on the fuel supply to the fuel injection pump.
14. Rotate the flywheel / crankshaft clockwise until fuel is pumped from the nozzle of the spill-timing tool.

Note: The fuel injection pump pumps fuel to the fuel injector only once every two engine revolutions.

15. Slowly rotate the flywheel / crankshaft clockwise until the TDC mark on the flywheel is at approximately the 9 o'clock position.
16. Lightly "Flick" the timing tool nozzle with your finger to remove bubbles and establish a fuel level at approximately half the height of the nozzle (**Figure 7-11, (2)**).
17. Very slowly rotate the crankshaft clockwise until the fuel level in the nozzle of the spill-timing tool, or in the delivery valve, just begins to move. Immediately stop rotating the crankshaft. If no fuel movement is noticed, rotate the flywheel clockwise until the TDC mark is again at the 9 o'clock position and repeat the process.
18. Without moving the flywheel, insert a wooden wedge between the flywheel and the engine crankcase to hold the flywheel stationary.
19. Check the position of the flywheel target timing mark (**Figure 7-12, (1)**) on the flywheel grid in relation to the TDC timing mark (**Figure 7-12, (2)**) on the crankcase cooling fin.
 - If the two marks are aligned, the fuel injection timing is correct. Proceed to Step 21.
 - If the marks do not align, adjust the fuel injection timing. Do not rotate the flywheel and proceed to *Adjusting Fuel Injection Timing on page 7-14*.

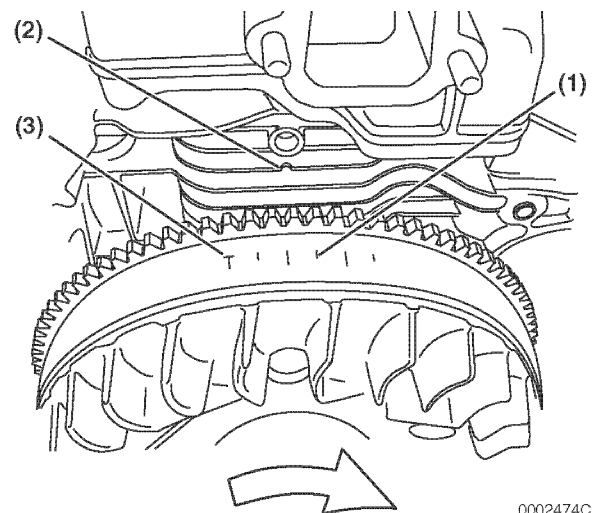

0002474C

- 1 – Target Timing Mark
- 2 – TDC Timing Mark
- 3 – TDC -Top Dead Center

Figure 7-12

IMPORTANT

Always turn the crankshaft in a clockwise direction when checking fuel injection timing.

20. Repeat steps 15-20 two or three times to verify timing.
21. Remove the spill-timing tool.
22. Remove the wooden wedge.

IMPORTANT

Always use a wrench to hold the fuel injection pump fuel delivery valve to prevent loosening of the delivery valve when loosening or tightening the high-pressure fuel injection lines.

- Note: To prevent "rounding" the fuel line nuts always use a "line" or "flare nut" wrench.
23. Install the high-pressure fuel injection line and tighten to specifications. *See Special Torque Specifications on page 7-4.*
 24. Install the cooling fan housing and recoil.
 25. Prime the fuel system. *See Priming the Fuel System on page 4-12.* Operate the engine and check for fuel leaks.

Adjusting Fuel Injection Timing

If the timing marks did not align when performing the *Checking Fuel Injection Timing* procedure on page 7-11, perform the following steps to properly time the engine.

1. If not already completed, verify actual piston TDC, See *Checking Actual Piston TDC (Top Dead Center)* on page 6-36.
2. Leave the adjustment jig and the spill-timing tool installed on the fuel injection pump. Return the throttle control lever to the minimum speed position.
3. Ensure the wooden wedge is in place and the flywheel has not rotated since the timing check procedure.
4. Observe the difference between the "actual" timing setting and the "target" timing setting.
 - If the measured timing mark (**Figure 7-13, (2)**) is closer to TDC (**Figure 7-13, (5)**) than the target timing mark (**Figure 7-13, (3)**), the timing is "retarded" and must be advanced. To advance the timing, reduce shim thickness.
 - If the measured timing mark (**Figure 7-13, (4)**) is further from TDC than the target timing mark (**Figure 7-13, (3)**), the timing is "advanced" and must be retarded. To retard the timing, increase shim thickness.

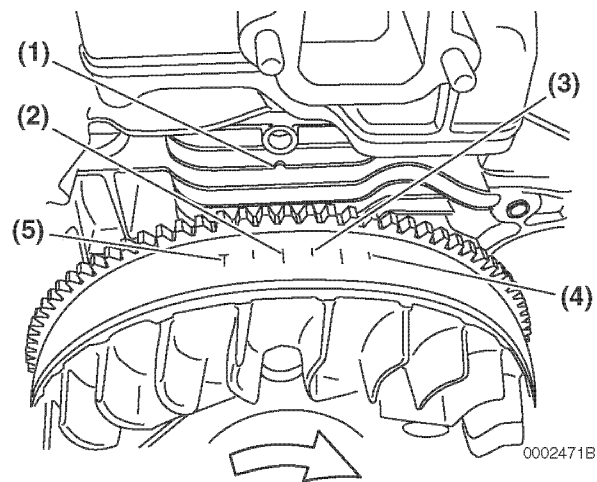

- 1 – TDC Timing Mark
- 2 – Measured Timing Mark (Timing Retarded)
- 3 – Target Timing Mark (15°)
- 4 – Measured Timing Mark (Timing Advanced)
- 5 – TDC -Top Dead Center

Figure 7-13

5. Calculate the amount of shim thickness that is required to correct the timing. Each 0.004 in. (0.1 mm) thickness change will result in 1° timing change.

Note: Shims are available in a set, including one each of the following thicknesses 0.008 in. (0.20 mm), 0.010 in. (0.25 mm), 0.012 in. (0.30 mm) and 0.014 in. (0.35 mm). You may use multiple shim sizes to reach the desired timing setting. The shims are not marked, so you will have to measure them with a micrometer.

6. Remove the fuel injection pump, see (*Removal of Fuel Injection Pump on page 7-16*) and the shim(s) from between the fuel injection pump and the engine crankcase. Measure and record the thickness of the existing shim(s).

Example:

Subject engine - L70N

Target timing = $13^{\circ} \pm 1.0^{\circ}$ BTDC

Measured timing = 10° BTDC (3° retarded)

Calculate the timing difference: $13^{\circ} - 10^{\circ} = 3^{\circ}$

Determine the difference in shim thickness:

Where: 0.004 in. (0.1 mm) = 1°

$3^{\circ} \times 0.004$ in.(0.1 mm) = 0.012 in. (0.3 mm)

In this case, the timing was “retarded” so the desired total shim(s) thickness needs to be 0.012 in. (0.3 mm) thinner than the original shim(s).

Measuring with a micrometer, if the existing shim(s) thickness is 0.048 in. (1.20 mm), the new thickness should be:

(0.048 in.- 0.012 in. = 0.036 in.) 3 x 0.012 in. shims = 0.036 in. total shims. (Equals 13 degrees BTDC)

or

(1.20 mm - 0.3 mm = 0.90 mm) 3 x 0.3 mm shims = 0.90 mm total shims. (Equals 13 degrees BTDC)

7. Install the calculated shim(s) (**Figure 7-14, (1)**) over the injection pump mounting studs and onto the crankcase mounting surface. Note: Do not use any sealant for this assembly.

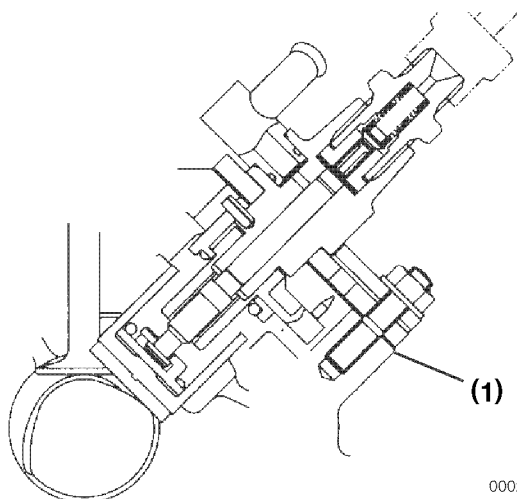

Figure 7-14

8. Install the fuel injection pump. Take up any slack in the mounting hardware by manually rotating the injection pump clockwise as you tighten the injection pump mounting nuts.
9. Tighten the fuel injection pump mounting nuts to specification. *See Special Torque Specifications on page 7-4.*
10. Remove the wooden wedge and repeat the timing procedures. *See Checking Fuel Injection Timing on page 7-11 and Adjusting Fuel Injection Timing on page 7-14* until fuel injection timing is correct.
11. When the timing is correctly set, remove the fuel adjustment jig and spill-timing tool and the wooden wedge.
12. Reinstall the injection pump inspection cover and gasket. Tighten the mounting nut to specification. *See Special Torque Specifications on page 7-4.*

IMPORTANT

Always use a wrench to hold the fuel injection pump fuel delivery valve to prevent loosening of the delivery valve when loosening or tightening the high-pressure fuel injection lines.

- Note: To prevent “rounding” the fuel line nuts, always use a “line” or “flare nut” wrench.
13. Install the high-pressure fuel injection line and tighten to specifications. *See Special Torque Specifications on page 7-4.*
 14. Install the cooling fan housing and recoil.
 15. Prime the fuel system. *See Priming the Fuel System on page 4-12.* Operate the engine and check for fuel leaks.

FUEL INJECTION PUMP

Removal of Fuel Injection Pump



Note: Be sure the speed control lever is set to the SLOW-IDLE position before removing the fuel injection pump.

1. Clean the areas around the fuel injection pump (Figure 7-15, (6)) and fuel injector.
2. Close any fuel valves in the fuel supply line.

IMPORTANT

Always use a wrench to hold the fuel injection pump fuel delivery valve to prevent loosening of the delivery valve when loosening or tightening the high-pressure fuel injection lines.

Note: To prevent "rounding" the fuel line nuts, always use a "line" or "flare nut" wrench.

3. Remove the high-pressure fuel injection line (Figure 7-15, (1)). Use care not to bend the line.
4. Remove the fuel supply line (Figure 7-15, (2)).
5. Plug or cap all openings to minimize leaks and prevent contamination.
6. Remove the three nuts (Figure 7-15, (5)) fastening the fuel injection pump into the cylinder block.

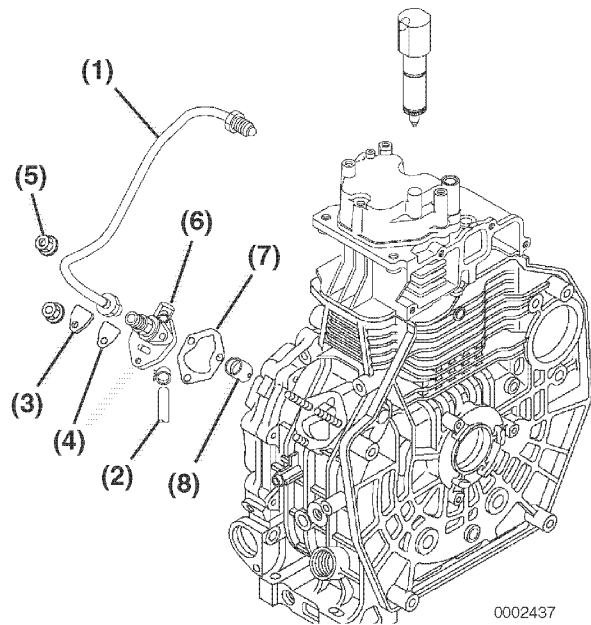

Figure 7-15

7. Remove the inspection cover (Figure 7-15, (3)) and gasket (Figure 7-15, (4)).
8. Remove the fuel injection pump (Figure 7-16).

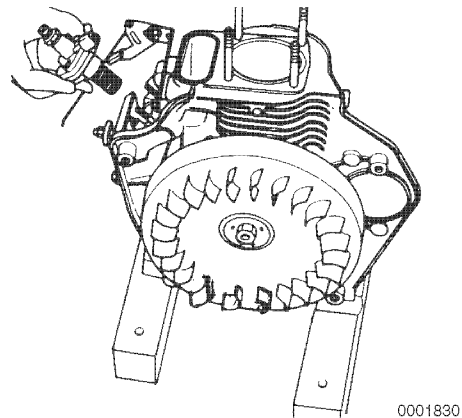

Figure 7-16

9. Remove the shim(s) (Figure 7-15, (7)). Use care not to bend or damage the shim(s).

Note: The L48N model engines use a flat tappet.

The L70N and L100N model engines use a roller tappet.

- Remove the fuel injection pump tappet (**Figure 7-15, (8)**) from the crankcase. The tappet may stay in the cylinder block. You can remove it with your finger. Inspect the face or roller end of the tappet for damage or abnormal wear. See *Tappet* on page 6-50.

Note: The fuel injection pump is not designed to be tested or serviced. Do not disassemble the fuel injection pump. If the fuel injection pump requires servicing, it must be replaced with a new fuel injection pump.

Installation of Fuel Injection Pump

- Adjust the throttle control so the governor lever (**Figure 7-17, (1)**) fork is positioned in the center of the fuel injection pump opening.

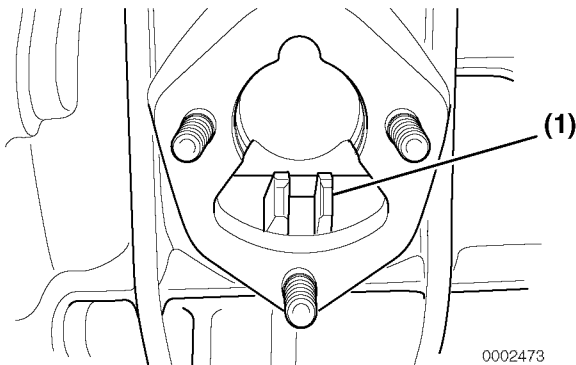
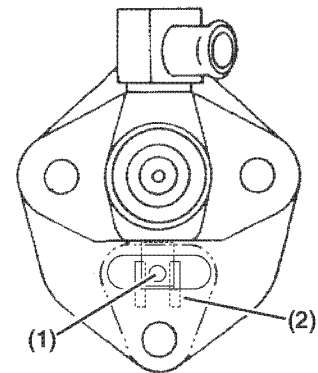

Figure 7-17

- Install the fuel injection tappet.
- Install the original fuel injection pump shim(s) (**Figure 7-19, (7)**).
- Install the fuel injection pump (**Figure 7-19, (6)**) into the crankcase, ensuring that the fuel injection pump lever pin (**Figure 7-18, (1)**) is engaged in the governor lever fork (**Figure 7-18, (2)**).

Hold the injection pump against the crankcase and move the speed control. Make sure the fuel injection pump control lever also moves.

To reduce any play in the mounting hardware, manually rotate the fuel injection pump clockwise while tightening the mounting nuts.



0002438B

Figure 7-18

- Install the two side mounting nuts (**Figure 7-19, (5)**) and tighten to specification. See *Special Torque Specifications* on page 7-4.

Note: If the original fuel injection pump, camshaft and injection pump tappet (**Figure 7-19, (8)**) are being reused, you do not need to recheck the fuel injection timing. If any of these components have been replaced, it will be necessary to check the fuel injection timing. See *Checking and Adjusting Fuel Injection Timing* on page 7-11.

FUEL SYSTEM

6. Install the inspection cover (**Figure 7-19, (3)**), gasket (**Figure 7-19, (4)**) and nut. Tighten to specification. See *Special Torque Specifications on page 7-4*.

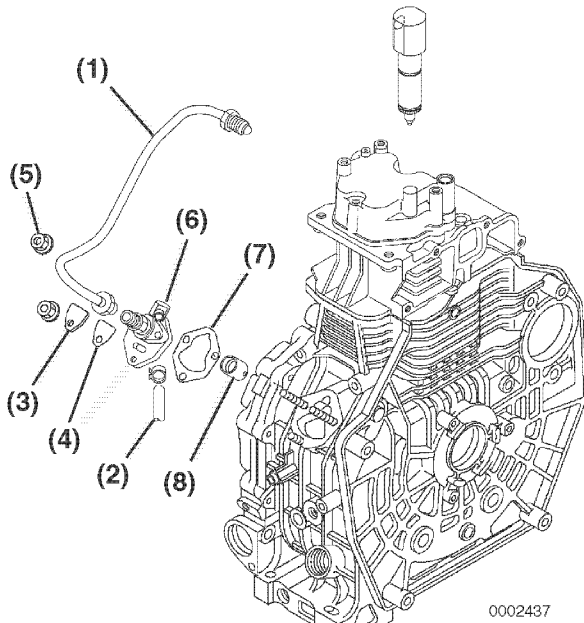

Figure 7-19

IMPORTANT

Always use a wrench to hold the fuel injection pump fuel delivery valve to prevent loosening of the delivery valve when loosening or tightening the high-pressure fuel injection lines.

- Note: To prevent "rounding" the fuel line nuts, always use a "line" or "flare nut" wrench.
7. Install the fuel injection high-pressure fuel injection line (**Figure 7-19, (1)**). Tighten the nuts to specification. See *Special Torque Specifications on page 7-4*.
 8. Install the fuel supply line (**Figure 7-19, (2)**).
 9. Prime the fuel system. See *Priming the Fuel System on page 4-12*.
 10. Operate the engine and check for fuel leaks.

Replacement and/or Adjustment of the Fuel Limiter

If the fuel limiter (**Figure 7-20, (1)**) is damaged, or it is obvious the fuel limiter adjustment has been tampered with, it will be necessary to replace and/or adjust the fuel limiter using the following procedure.

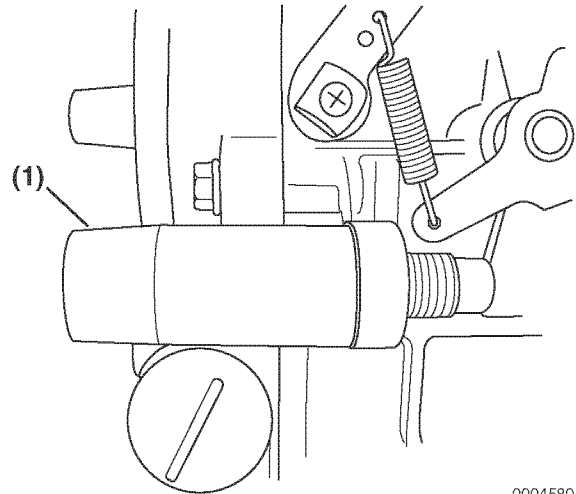

Figure 7-20

IMPORTANT

This is an emissions related procedure. Follow the procedure carefully to assure emissions compliance. It is good service practice to always keep good service records.

If you are replacing the fuel injection pump, replace it before continuing with the fuel limiter replacement and/or adjustment procedure". See *Installation of Fuel Injection Pump on page 7-17*. Do not install the inspection window cover and gasket at this time.

1. Confirm that the fuel injection timing is correct. Adjust the fuel injection timing if needed. For the fuel injection timing procedure. See *Checking Fuel Injection Timing on page 7-11* and *Adjusting Fuel Injection Timing on page 7-14*.

- Install the fuel adjustment jig (**Figure 7-21, (2)**), Yanmar P/N 114771-92310, in the fuel injection pump inspection window. Using the inspection window cover plate nut, fasten the fuel adjustment jig aligning the upper left edge of the jig (**Figure 7-21, (4)**) to the alignment mark scribed on the face of the fuel injection pump (**Figure 7-21, (1)**) base plate (**Figure 7-21, (3)**).

Note: Be sure to keep the fuel adjustment jig parallel to the inspection window opening. (**Figure 7-21** shows the alignment mark for clarity only. The edge of the jig should be directly on the mark when installed properly.)

To assist in the alignment of the fuel adjustment jig, tighten the attaching nut to just hold the jig "lightly" in place. Then "lightly" tap the jig into the proper position. Once the jig is in position, tighten the attaching nut to hold the jig firmly in place.

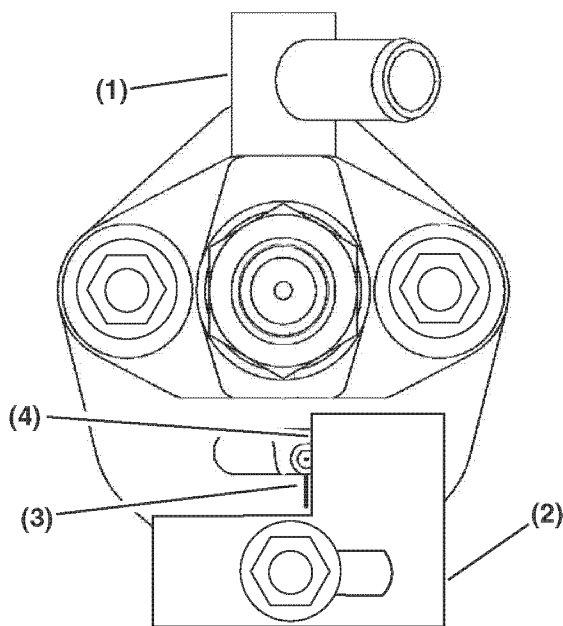

0004579

Figure 7-21

With the fuel adjustment jig in place, replacement or adjustment of the fuel limiter can continue.



Note: When replacing or adjusting the fuel limiter, a new fuel limiter tamper-proof cover and lock plate must be used. Using the correct parts catalog for the specific engine you are working on to order these parts.

- To remove the tamper-proof cover from the fuel limiter, use a hacksaw or a cut-off wheel to carefully make a small slot (**Figure 7-22, (2)**) in the side of the tamper-proof cover (**Figure 7-22, (1)**).

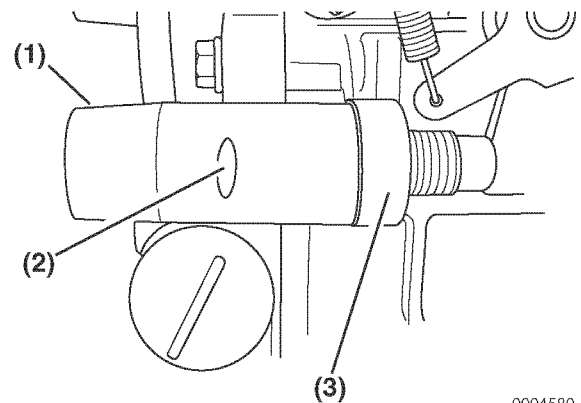

0004580

Figure 7-22

Note: Be careful not to damage the cylinder block boss (**Figure 7-22, (3)**) when removing the tamper-resistant cover.

FUEL SYSTEM

- Use a hammer and metal chisel (**Figure 7-23, (2)**) to drive off the tamper-resistant cover (**Figure 7-23, (1)**). The chisel should be held at about a 30° angle to the tamper-resistant cover, and engaged in the slot. Discard the old tamper-resistant cover.

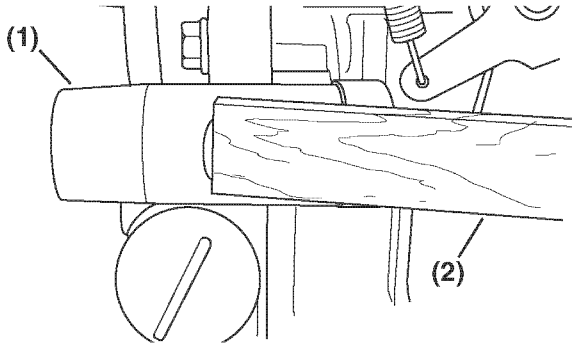
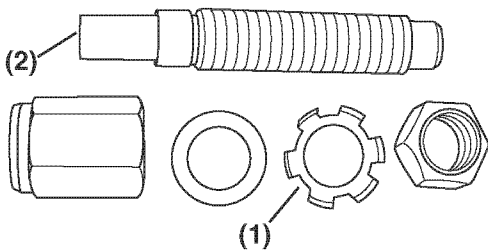

Figure 7-23

- If installing a new fuel limiter, remove the original fuel limiter assembly from the threaded boss in the cylinder block. Disassemble the original fuel limiter assembly **Figure 7-24** and discard the fuel limiter (**Figure 7-24, (2)**) and lock plate (**Figure 7-24, (1)**).
- Reassemble the fuel limiter assembly with the new fuel limiter and the new lock plate.

Note: If the original fuel limiter is to be reused, the only part needing replacement is the lock plate.



0004582

Figure 7-24

- Assemble the new fuel limiter assembly **Figure 7-25** without the new tamper-resistant cover.

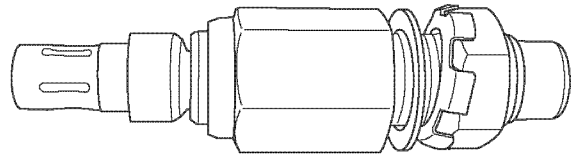

0004583

Figure 7-25

- Thread the new fuel limiter assembly into the cylinder block boss until the threads on the fuel limiter extend about 0.250 in. (6.35 mm) past the surface of the cylinder block boss. Thread on the fuel limiter locking nuts, but do not tighten at this time.

Note: The fuel limiter is equipped with a "thermostat-like" wax pellet that contracts when cold, supplying more fuel for cold starting. When the engine reaches operating temperature, 30°C [86°F] or greater, the fuel limiter tip extends by 0.9 mm to return to the normal fuel setting.

IMPORTANT

Do not use an open flame to heat the fuel limiter.

- To adjust the fuel limiter, heat the rear portion of the fuel limiter with a hot air gun or hair dryer to assure that it is above 30°C [86°F], so the fuel limiter pin will be fully extended.
- Rotate the speed control lever fully clockwise until it stops. Before proceeding, check that the tip of the fuel limiter is not touching the control lever (**Figure 7-26, (1)**).

L48N Models:

- Thread the fuel limiter into the crankcase boss until the fuel limiter pin just touches the control lever. Do not depress the fuel limiter pin.

L70N Models,

- Adjust the fuel limiter using the same procedure as the L48N above. Then move the speed control lever counter clockwise until the fuel limiter pin is no longer touching the control lever. Then turn the fuel limiter "in" an additional 1/3 turn.

L100N Models

- Adjust the fuel limiter using the same procedure as the L48N above. Move the speed control lever counter clockwise away from the fuel limiter and then turn the fuel limiter "in" an additional 1/2 turn.

11. Without changing the adjustment of the fuel limiter, tighten the fuel limiter mounting nuts to specifications. See *Special Torque Specifications on page 7-4*.

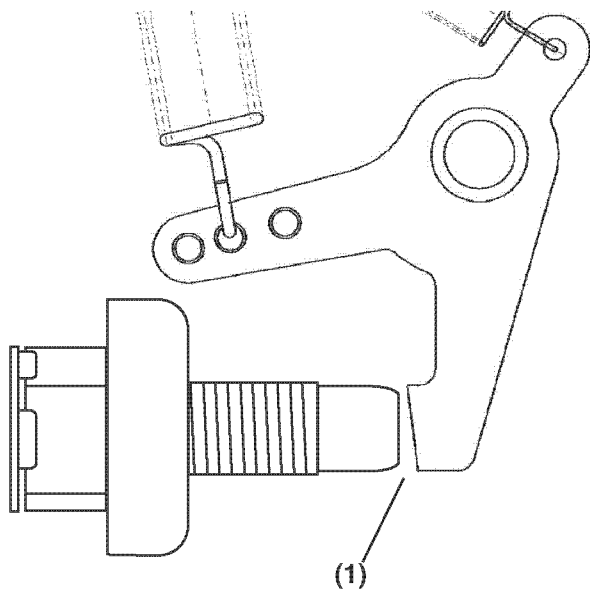

0004584

Figure 7-26

12. Remove the fuel adjustment jig from the fuel injection pump. Install the inspection window cover plate using a new gasket and tighten the nut to specifications. See *Special Torque Specifications on page 7-4*.
13. Install the new fuel limiter tamper resistant cover (**Figure 7-27, (1)**). Do not reuse the old cover. Use a soft-faced hammer to "tap" the tamper-resistant cover into place. When properly installed, there should not be a gap (**Figure 7-27, (2)**) between the tamper-resistant cover and the cylinder block mounting boss (**Figure 7-27, (3)**).

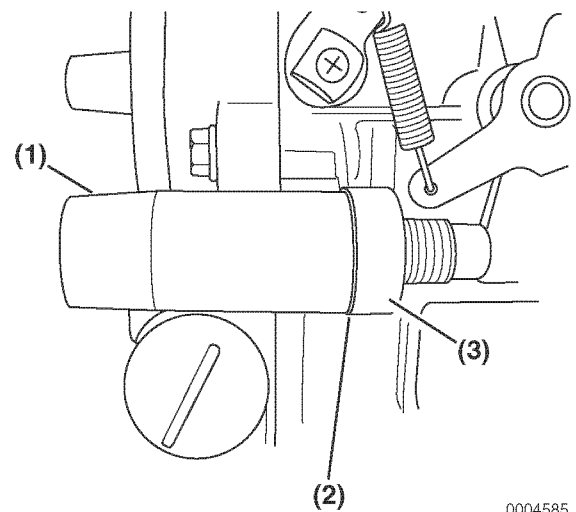

0004585

Figure 7-27

FUEL INJECTOR

Removal of Fuel Injector

1. Close any fuel valves in the fuel supply line.

IMPORTANT

Always use a wrench to hold the fuel injection pump fuel delivery valve to prevent loosening of the delivery valve when loosening or tightening the high-pressure fuel injection lines.

Note: To prevent "rounding" the fuel line nuts, always use a "line" or "flare nut" wrench.

2. Remove the high-pressure fuel injection line.
3. Disconnect the fuel return hose from the fuel injector.
4. Remove the fuel injector retainer plate (**Figure 7-28, (1)**).
5. Remove the fuel injector from the cylinder head.

If the fuel injector "sticks" in the cylinder head, reinstall the high-pressure fuel injection line and pry up on the fuel line nut.

6. Remove the injector nozzle gasket (**Figure 7-28, (2)**) and spacer (**Figure 7-28, (3)**). If the injector nozzle gasket and spacer remain in the cylinder head, remove them from the cylinder head by threading an 8 mm or 9 mm bolt, at least 200 mm long, into the gasket. Use the bolt as a puller. Discard the gasket.

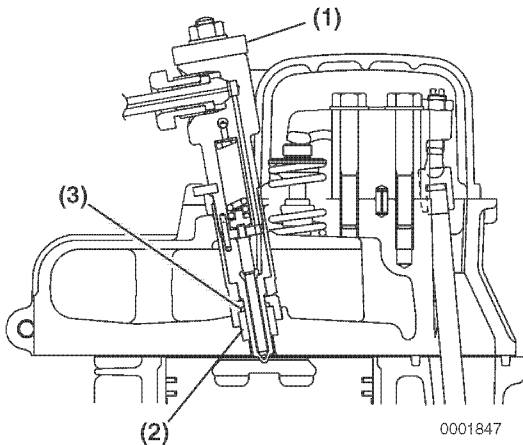



Figure 7-28

Testing of Fuel Injector

CAUTION
<p>Never use a steel wire brush to clean fuel injectors. Damage to the nozzle and other components is likely to result.</p>
<small>0000172en</small>

WARNING

<p>ALWAYS wear SAFETY GLASSES while servicing the engine to prevent possible eye injury.</p>
<small>0000013en</small>

WARNING

<p>HIGH-PRESSURE HAZARD!</p> <ul style="list-style-type: none"> • Avoid skin contact with the high-pressure diesel fuel spray caused by a fuel system leak such as a broken fuel injection line. High-pressure fuel can penetrate your skin and result in serious injury. If you are exposed to high-pressure fuel spray, obtain prompt medical treatment. • NEVER check for a fuel leak with your hands. ALWAYS use a piece of wood or cardboard. Have your authorized Yanmar industrial engine dealer or distributor repair the damage. • Failure to comply could result in death or serious injury.
<small>0000008en</small>

1. Thoroughly clean the fuel injector nozzle using clean diesel fuel and a brass wire brush.
2. Visually inspect the fuel injector nozzle for deposits or damage. Clean, repair or replace as necessary.

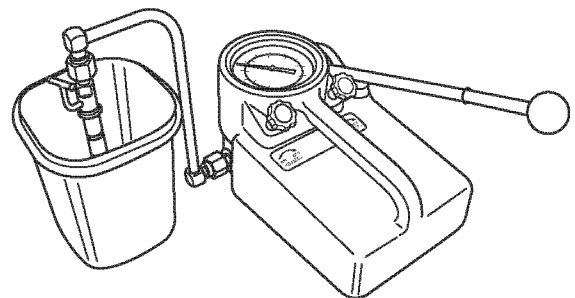
Note: Test the fuel injector using an injection nozzle tester (**Figure 7-29**). Operate the tester following the information provided by the tester manufacturer. Use clean, filtered fuel or FIE calibration fluid for the test.

3. Using the correct adapter, connect the fuel injector to a nozzle tester. Aim the fuel injector into a suitable container to contain the fuel spray.



0000581B

Figure 7-29

4. Pump the operating lever of the tester slowly, observing the pressure reading at the point where the fuel injector begins spraying fuel. See *Test and Adjustment Specifications on page 7-4*, for correct pressure readings.

Note: Opening pressure of a new fuel injector will be approximately 72.5 psi (0.5 MPa, 5 kgf/cm²) higher than one that has been operated for five hours or longer.

- Pump the operating lever slowly to hold the pressure steady at a point just below the opening pressure and hold for five seconds. Observe the injector to see that it is sealing properly and is not "dripping." If fuel leaks from the return fuel line fitting, check that the nozzle case nut is tight. Repair or replace the fuel injector if fuel continues to leak from either the return line fitting or nozzle.
- Pump the operating lever more rapidly to repeatedly "pop" the injector and observe the spray pattern. The pattern should be a very fine uniform spray (**Figure 7-30**). If a dripping or an uneven pattern is seen (**Figure 7-31**), service or replace the injector.

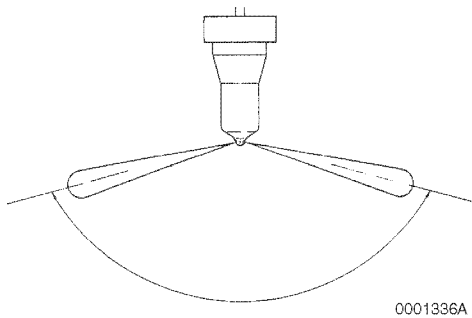

Figure 7-30

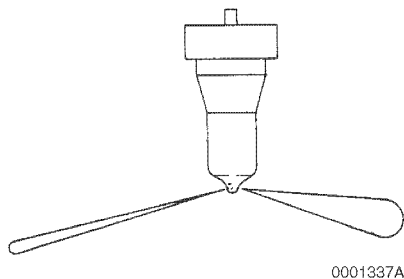

Figure 7-31

If the fuel injector fails any of these tests, it should be serviced or replaced as necessary. If the pressure is outside specified limits, adjust the pressure. See *Adjusting Fuel Injector Pressure* on page 7-25.

Disassembly and Inspection of Fuel Injector

CAUTION

Never use a steel wire brush to clean fuel injectors. Damage to the nozzle and other components is likely to result.

0000172en

- Clean carbon from used injectors using clean diesel fuel. Hardened deposits or varnish can be cleaned using a brass wire brush.

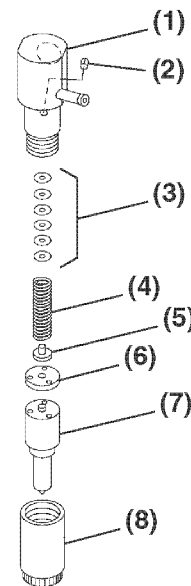

- Injector Body
- Alignment Pin
- Pressure Adjusting Shims
- Spring
- Spring Seat
- Valve Stop Spacer
- Nozzle Body and Valve
- Nozzle Case Nut

Figure 7-32

- Place the fuel injector in a soft-jawed vise with the nozzle pointing up.
- Remove the nozzle case nut.
- Carefully remove the injector from the vise.

5. Turn the injector over and remove the nozzle body, nozzle valve, valve stop spacer, nozzle spring seat, nozzle spring and shims.
6. Inspect the sealing surfaces (**Figure 7-33, (2)**) between the valve stop spacer and nozzle body for nicks or scratches. Check the contact area between the valve stop spacer and the nozzle valve (**Figure 7-33, (1)**) for scoring or pitting. Use a magnifying glass to inspect.

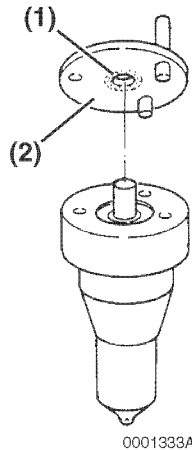

Figure 7-33

7. Perform a nozzle valve slide test:
 - (a) Wash nozzle body and valve in clean diesel fuel.
 - (b) While holding the nozzle body vertical, pull the nozzle valve about two-thirds of the way out (**Figure 7-34**).
 - (c) Manually move the nozzle valve up and down in the nozzle body. It should move smoothly with no binding.

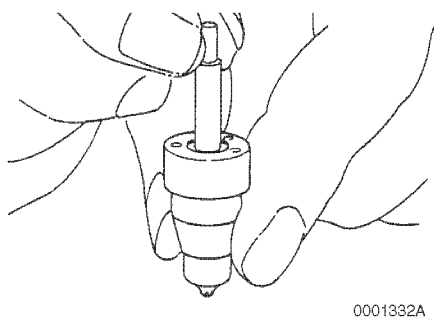
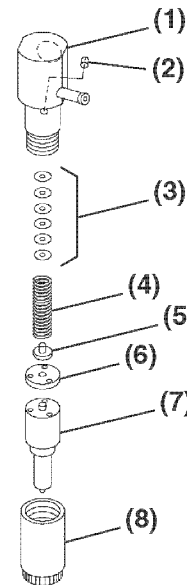

Figure 7-34

Replace the fuel injector assembly if it fails any inspection.

Adjusting Fuel Injector Pressure

The fuel injectors open when pressure reaches a predetermined pressure threshold. They close when the pressure is reduced below that threshold. The pressure threshold can be adjusted by adding or removing shims (**Figure 7-35, (3)**).



- 1 – Injector Body
- 2 – Alignment Pin
- 3 – Pressure Adjusting Shims
- 4 – Spring
- 5 – Spring Seat
- 6 – Valve Stop Spacer
- 7 – Nozzle Body and Valve
- 8 – Nozzle Case Nut

Figure 7-35

Note: The injection pressure will change by approximately 284 psi (1.96 MPa, 20 kgf/cm²) for every 0.004 in. (0.1 mm) shim thickness. Add a shim(s) to increase the injector opening pressure. Remove a shim(s) to decrease injector opening pressure.

See the parts catalog for available shims.

FUEL SYSTEM

1. Disassemble the fuel injector assembly. See *Disassembly and Inspection of Fuel Injector* on page 7-24.
2. Remove or add adjusting shims as needed.
3. Assemble the fuel injector assembly. See *Reassembly of Fuel Injector* on page 7-26.
4. Retest the fuel injector. See *Testing of Fuel Injector* on page 7-23. If the injector cannot be adjusted to the appropriate pressure, discard and replace the fuel injector.

Reassembly of Fuel Injector

1. Secure the fuel injector in a soft-jawed vise with the nozzle end up.
2. Install the shims, nozzle spring, nozzle spring seat, valve stop spacer, nozzle valve and nozzle body.
3. Install the nozzle case nut. Tighten it to specification. See *Special Torque Specifications* on page 7-4.

Installation of the Fuel Injector

1. Install a new nozzle spacer (**Figure 7-36, (3)**) and gasket (**Figure 7-36, (2)**) on the fuel injector.

See the parts catalog for correct part number(s).

2. Install the fuel injector in the cylinder head. Align the alignment pin with the groove in the cylinder head and high-pressure outlet as shown, then push the fuel injector into place.

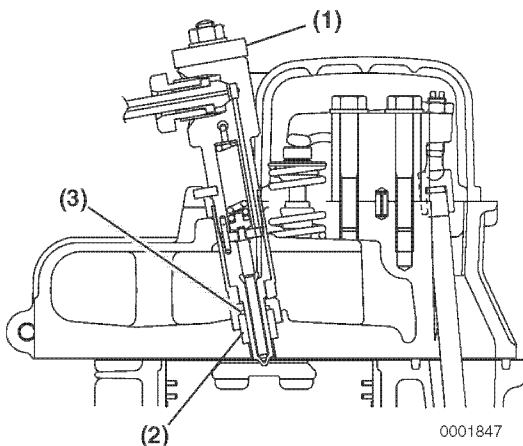

Figure 7-36

3. Install the injector retainer plate (**Figure 7-36, (1)**) and tighten the nuts to specification. See *Special Torque Specifications* on page 7-4.

IMPORTANT

Always use a wrench to hold the fuel injection pump fuel delivery valve to prevent loosening of the delivery valve when loosening or tightening the high-pressure fuel injection lines.

Note: To prevent “rounding” the fuel line nuts, always use a “line” or “flare nut” wrench.

4. Install the high-pressure fuel injection line. Tighten to specifications. See *Special Torque Specifications* on page 7-4.
5. Install the return fuel hose.
6. Prime the fuel system. See *Priming the Fuel System* on page 4-12.
7. Operate the engine and check for fuel leaks.

SPEED CONTROL DEVICE

Four different speed control designs are available on the LN Series engine, depending on engine model and intended usage. The position where the governor springs are installed differs depending on the rated rpm and the design of the speed control.

For removal and installation of the L48N model speed control device. See *Replacement of Throttle Shaft Seal - L48N Models* on page 6-56.

For removal and installation of the L70N and L100N models. See *Replacement of Throttle Shaft Seal - L70N and L100N Models* on page 6-57.

Should the high-idle adjustment bolt (**Figure 7-37, (1)**) be damaged and require replacement, or it is obvious that the high-idle adjustment has been tampered with, use the following procedure to replace and/or adjust the high-idle adjustment bolt.

1. Select the replacement parts, as required, and a new tamper-proof wire and seal from the parts catalog for the specific engine you are working on.
2. Operate the engine at no-load full throttle. Adjust the engine RPM to the correct specification. See *General Engine Specifications* on page 4-6.
3. After adjusting the engine speed to the correct RPM, install the tamper-proof wire (**Figure 7-37, (2)**).

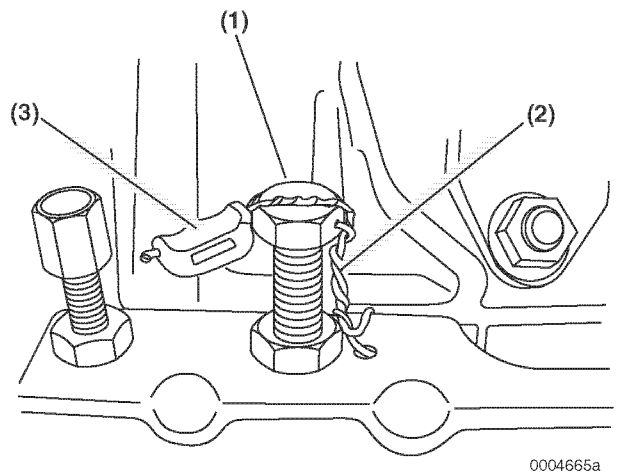

0004665a

Figure 7-37

4. After installing the wire, install and crimp the tamper-proof seal (**Figure 7-37, (3)**) onto the wire.

Use the following charts and graphics (**Figure 7-38**) (**Figure 7-39**) (**Figure 7-41**) (**Figure 7-42**) to determine the correct spring position for a given engine.

CAUTION

- **NEVER** remove or attempt to remove the tamper-proof devices from the high-speed throttle limit screw. This adjustment has been made at the factory to meet all applicable emissions regulations and then sealed.
- **DO NOT** attempt to remove or adjust the fuel limiter assembly.
- **NEVER** attempt to make adjustments to any sealed adjustment screw.
- Any alterations to this engine may affect the warranty coverage of this engine.
- See *Yanmar Limited Warranty in Section 2*.

0000174en

FUEL SYSTEM

Variable Speed Type

The variable speed control device can be moved and locked at any position. This control device can be converted to operate remotely.

Engine	L48N		L70N		L100N	
RPM Rating	3600 rpm	3000 rpm	3600 rpm	3000 rpm	3600 rpm	3000 rpm
Position of Regulator Spring	1-B	1-C	1-B	1-C	1-B	1-C

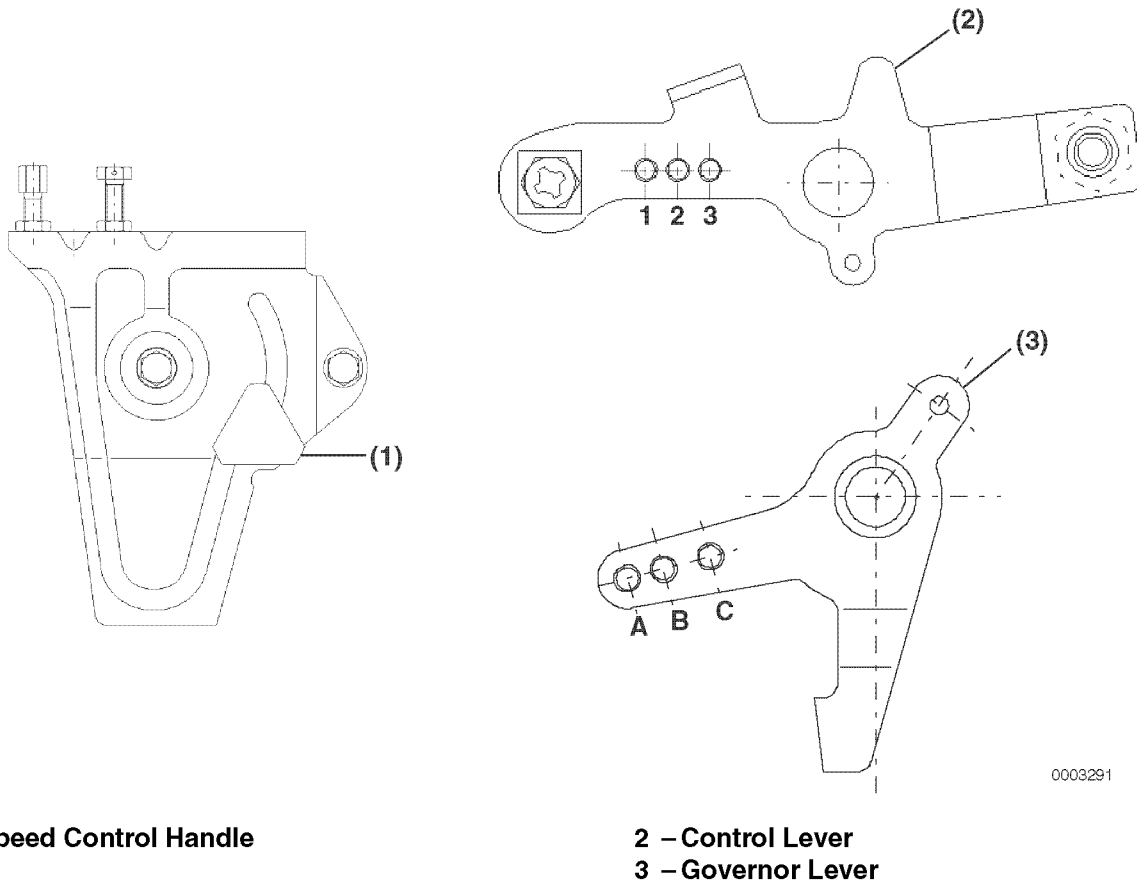
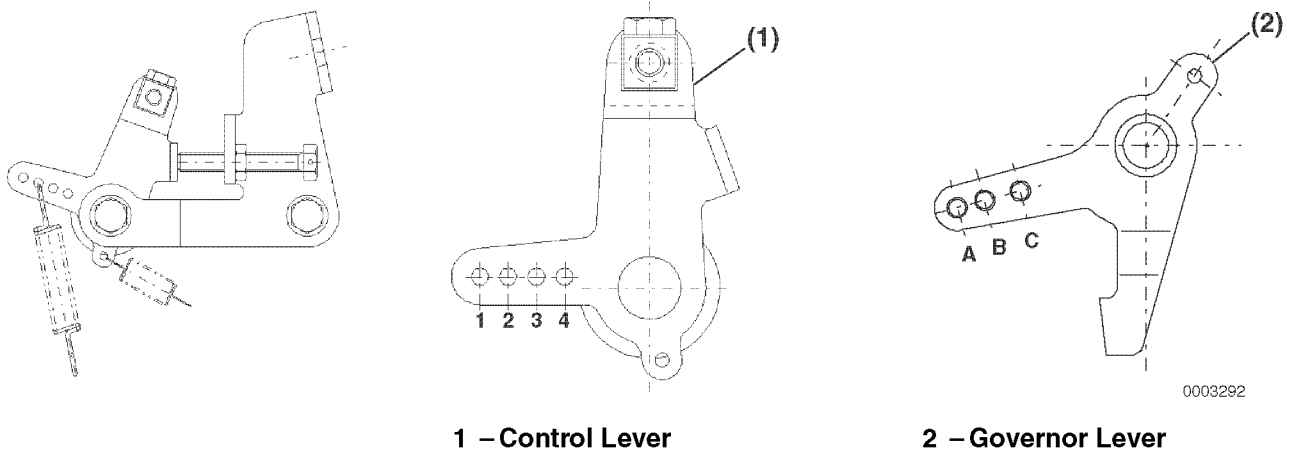

Figure 7-38

Remote Control Type

Engine	L48N		L70N		L100N	
RPM Rating	3600 rpm	3000 rpm	3600 rpm	3000 rpm	3600 rpm	3000 rpm
Position of Regulator Spring	1-B	1-C	1-B	1-C	1-B	1-C

Type A



1 – Control Lever

2 – Governor Lever

Figure 7-39

Type B

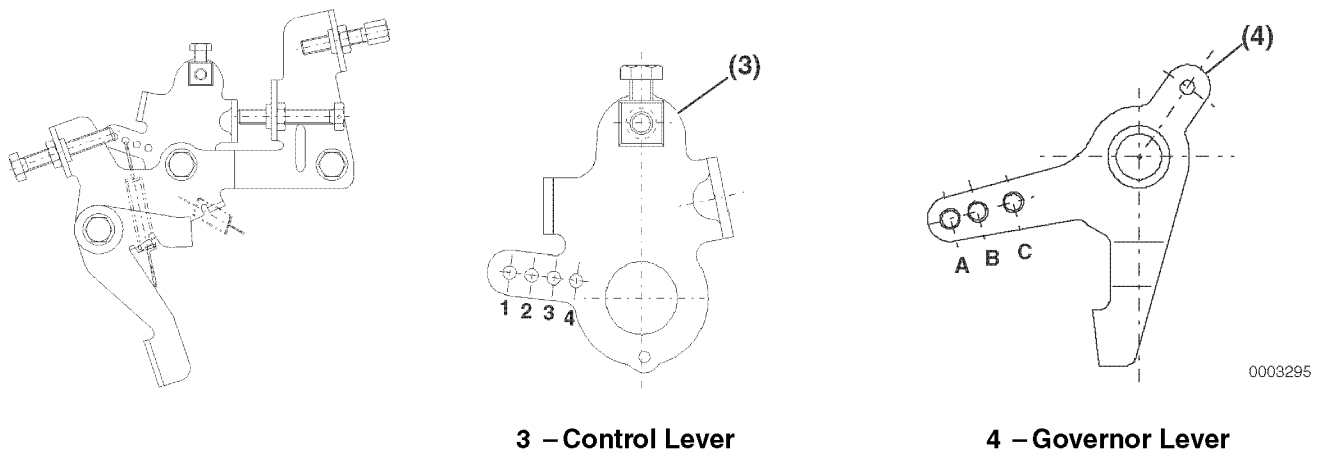

3 – Control Lever

4 – Governor Lever

Figure 7-40

FUEL SYSTEM

Variable Speed Friction Plate Type

The variable speed control device can be moved and locked at any position. This control can be converted to operate remotely.

Engine	L48N		L70N		L100N	
RPM Rating	3600 rpm	3000 rpm	3600 rpm	3000 rpm	3600 rpm	3000 rpm
Position of Regulator Spring	1-B	1-C	0-B	0-C	0-A	0-C

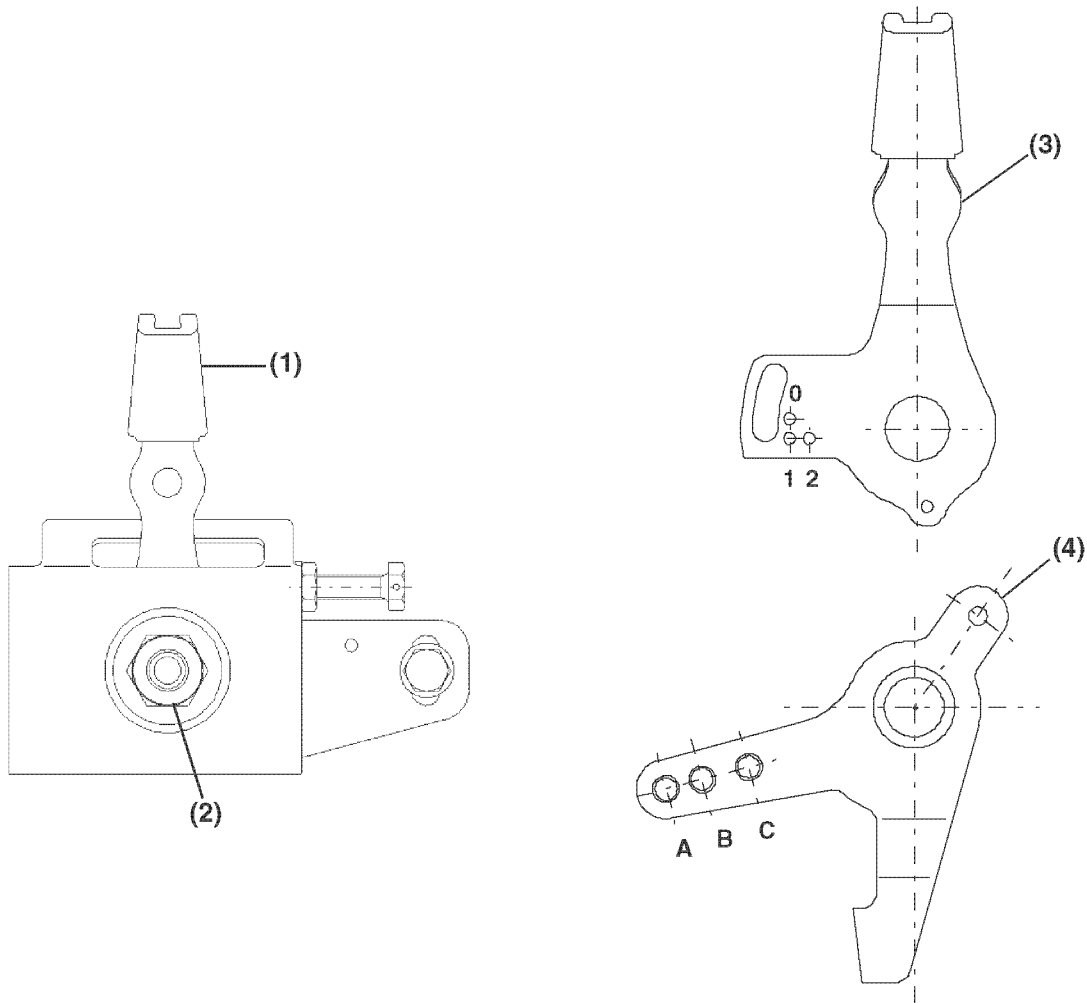

- 1 – Speed Control Lever
- 2 – Friction Control

- 3 – Control Lever
- 4 – Governor Lever

Figure 7-41

Constant Speed Type

The constant speed control device is used in applications where a constant engine rpm is wanted, such as generators. When moved to the full throttle position, the speed control lever “locks” at full throttle.

Engine	L48N		L70N		L100N	
RPM Rating	3600 rpm	3000 rpm	3600 rpm	3000 rpm	3600 rpm	3000 rpm
Position of Regulator Spring	1-B	2-C	0-B	0-C	0-A	1-C

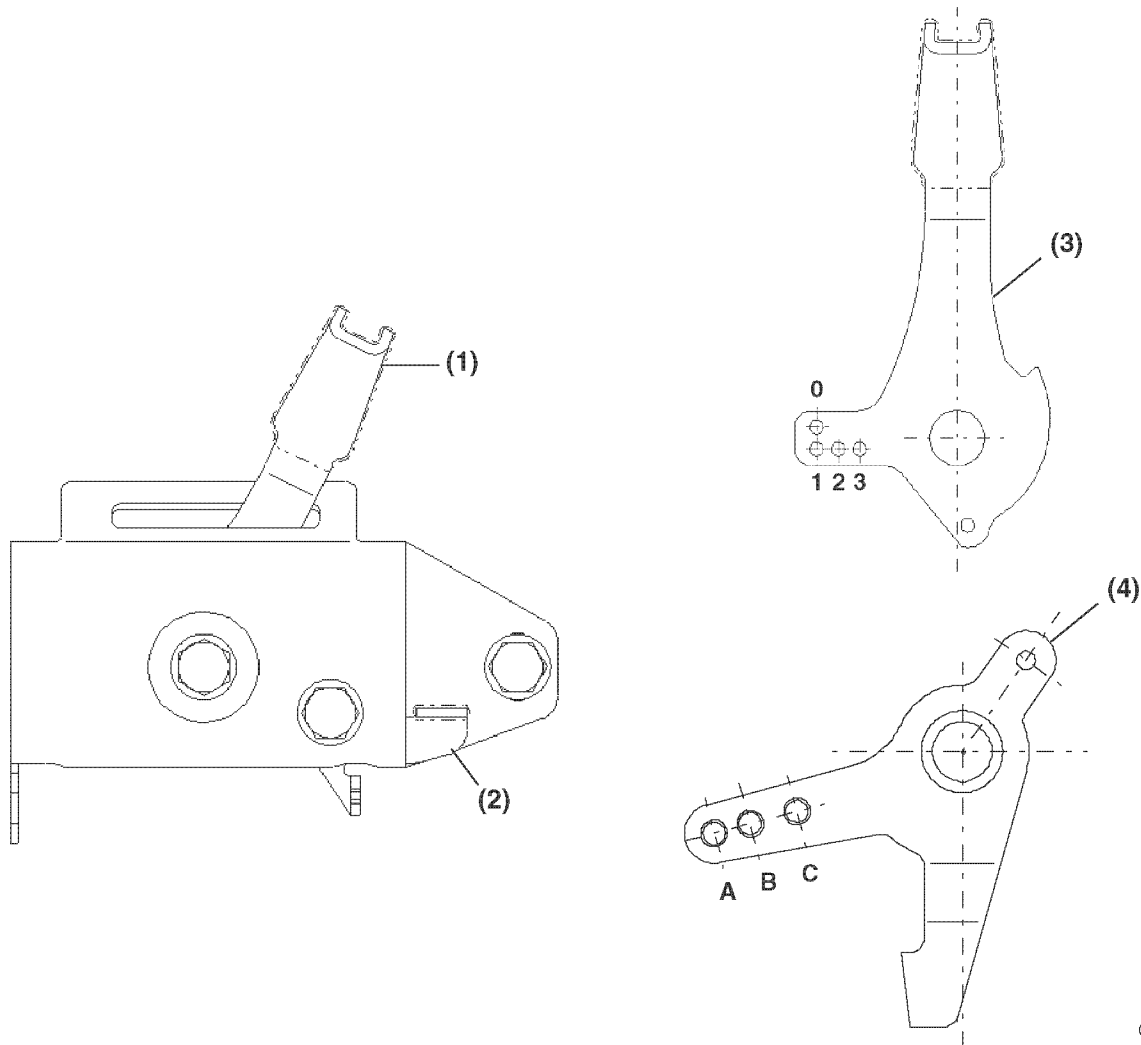

- 1 – Speed Control Lever
- 2 – Speed Control Release Lever

- 3 – Control Lever
- 4 – Governor Lever

Figure 7-42

0003294

This Page Intentionally Left Blank

Section 8



STARTER



	Page
Before You Begin Servicing	8-3
Introduction.....	8-5
Specifications	8-5
Special Service Tools.....	8-6
Measuring Instruments.....	8-6
Electric Starter Motor Components (Standard)	8-7
Electric Starter Motor Troubleshooting.....	8-8
Testing Electric Starter Motor Operation (Standard)	8-9
Checking Pinion Projection Length.....	8-9
No-Load Test.....	8-10
Electric Starter Motor (Standard).....	8-11
Disassembly of Electric Starter Motor	8-11
Inspection and Testing of Electric Starter Motor Components	8-13
Reassembly of Electric Starter Motor	8-17
Recoil Starter.....	8-20
Disassembly of Recoil Starter	8-20
Reassembly of Recoil Starter	8-21

This Page Intentionally Left Blank

BEFORE YOU BEGIN SERVICING

Before performing any service procedures within this section, read the following safety information and review the "Safety" section on page 3-1.

 WARNING

<p>ENTANGLEMENT HAZARD!</p> <ul style="list-style-type: none"> • ALWAYS stop the engine before you begin to service it. • NEVER leave the key in the key switch when you are servicing the engine. Someone may accidentally start the engine and not realize you are servicing it. • Failure to comply could result in death or serious injury.
0000010en

 WARNING

<p>SHOCK HAZARD!</p> <ul style="list-style-type: none"> • ALWAYS turn off the battery switch (if equipped) or disconnect the negative battery cable before servicing the electrical system. • Check the electrical harnesses for cracks, abrasions, and damaged or corroded connectors. ALWAYS keep the connectors and terminals clean. • Failure to comply could result in death or serious injury.
0000009en

 WARNING

<p>FUME / BURN HAZARD!</p> <ul style="list-style-type: none"> • ALWAYS read and follow safety related precautions found on containers of hazardous substances like parts cleaners, primers, sealants and sealant removers. • Failure to comply could result in death or serious injury.
0000014en

⚠ CAUTION



FLYING OBJECT HAZARD!

- **ALWAYS** wear eye protection when servicing the engine and when using compressed air or high-pressure water. Dust, flying debris, compressed air, pressurized water or steam may injure your eyes.
- Failure to comply may result in minor or moderate injury.

000003en

CAUTION

The starter motor is water-proofed according to JIS D 0203, R2 which protects the motor from rain or general cleaning. Do not use high-pressure wash or submerge the starter motor in water.

0000055en

CAUTION

Use a specialized battery charger to recharge a battery with a voltage of 8 volts or less. Booster starting a battery with a voltage of 8 volts or less will generate an abnormally high voltage and destroy electrical equipment.

0000056en

CAUTION

The starter motor can be damaged if operated continuously longer than 10 seconds while performing the no-load test.

0000034en

CAUTION

Make sure that the combined total resistance of the battery cable in both directions between the starter motor and the battery is within the value indicated on the wiring diagram. The starter motor will malfunction or break down if the resistance is higher than the specified value.

0000054en

INTRODUCTION

This section of the *Service Manual* covers the servicing of the recoil starter and electric starter motor (if equipped). Yanmar Electric starter motor, Part No. 114399-77010 is used in this section to show the service procedures for all starter motors. For specific part detail, see the *Yanmar Parts Catalog* for the engine being serviced.

SPECIFICATIONS

Engine Model		L48N, L70N, L100N	
Type		Conventional	
Hitachi Model Number		S114-414A	
Yanmar Part Number		114399-77010	
Nominal Output		12 V (0.8 kW)	
Weight		7.9 lb (3.6 kg)	
Rotation Direction (As Viewed From Pinion)		Counterclockwise	
Engagement System		Magnetic Shift	
No-load	Terminal Voltage / Current		11.5 VDC / 60 A (max)
	Revolution		7000 rpm (min)
Loaded	Terminal Voltage / Current		8 VDC / 200 A (max)
	Torque		27.7 in.-lb (0.32 kgf-m) (min)
Clutch System		Overrunning	
Pinion Projection Voltage at 212°F (100°C)		8 VDC max	
Pinion DP or Module / Number of Teeth		8	
Brush	Spring Force		3.81 - 4.85 lbf (17 - 21.6 N, 1.8 - 2.2 kgf)
	Height	Standard	0.55 in. (14 mm)
		Limit	0.43 in. (11 mm)
Solenoid Switch	Pull-In Coil Resistance		0.33 Ω at 68°F (20°C)
	Hold-In Coil Resistance		1.13 Ω at 68°F (20°C)
Commutator	Outside Diameter	Standard	1.30 in. (33 mm)
		Limit	1.26 in. (32 mm)
	Runout	Standard	0 in. (0.05 mm)
		Limit	0.02 in. (0.4 mm)
	Insulation Depth	Standard	0.02 - 0.03 in. (0.5 - 0.8 mm)
		Limit	0.01 in. (0.2 mm)
Armature	Runout	Standard	0.002 in. (0.05 mm)
		Limit	0.016 in. (0.4 mm)

STARTER

Bearings	Brush Side (shaft diameter)	0.4902 - 0.4909 in. (12.450 - 12.468 mm)
	Brush Side (bearing inside diameter)	0.4921 - 0.4928 in. (12.500 - 12.518 mm)
	Pinion Sliding Section (shaft diameter)	0.4921 - 0.4909 in. (12.450 - 12.468 mm)
	Pinion Sliding Section (bearing inside diameter)	0.493 - 0.494 in. (12.53 - 12.55)
	Pinion Side (shaft diameter)	0.4902 - 0.4909 in. (12.450 - 12.468 mm)
	Pinion Side (bearing inside diameter)	0.4921 - 0.4928 in. (12.500 - 12.518 mm)
Pinion Projection Length (Length L)		0.012 - 0.059 in. (0.3 - 2.5 mm)

SPECIAL SERVICE TOOLS

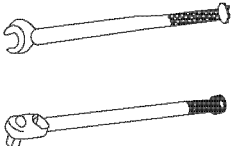
No.	Tool Name	Application	Illustration
1	Torque Wrench (Locally available)	For tightening nuts and bolts to the specified torque	 0000840

MEASURING INSTRUMENTS

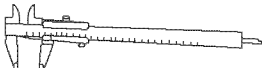
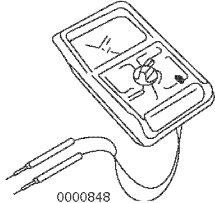
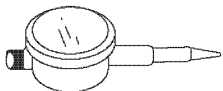
No.	Tool Name	Applicable Model and Tool Size	Illustration
1	Caliper	Locally available	 0000836
2	Multimeter	Locally available	 0000848
3	Dial Indicator	Locally available	 0000831
4	Force Gauge	Locally available	

Note: Tools not having Yanmar part numbers must be acquired locally.

ELECTRIC STARTER MOTOR COMPONENTS (STANDARD)

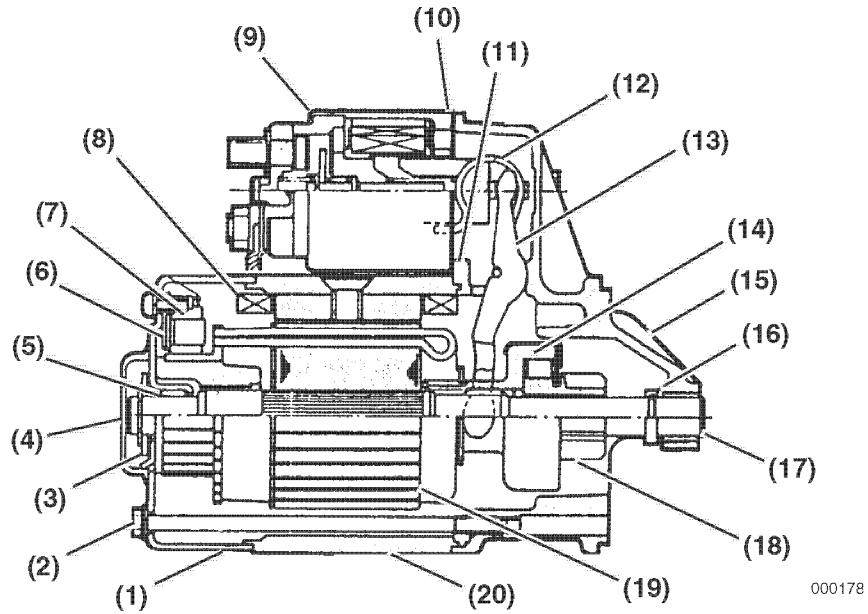

- | | | |
|------------------------|-------------------------|---------------------------|
| 1 – Rear Cover | 8 – Field Coil | 15 – Gear Housing |
| 2 – Through-Bolt | 9 – Solenoid Switch | 16 – Pinion Stop |
| 3 – Thrust Washer | 10 – Dust Cover | 17 – Gear Housing Bearing |
| 4 – Rear Dust Cover | 11 – Dust Cover | 18 – Pinion |
| 5 – Rear Cover Bearing | 12 – Torsion Spring | 19 – Armature |
| 6 – Brush Holder | 13 – Shift Lever | 20 – Field Housing |
| 7 – Brush | 14 – Overrunning Clutch | |

Figure 8-1

ELECTRIC STARTER MOTOR TROUBLESHOOTING

Step 1	Is starter motor operating?	No	See “ B ”
		Yes	See “ E ”
A	Are the pinion and ring gear meshing normal?	No	<ul style="list-style-type: none"> • Adjust / pinion engagement length. • Inspect shift lever for deformation, return spring for fatigue and pinion for sliding. • Repair meshing between pinion and ring gear or replace as needed.
		Yes	Pinion roller clutch or reduction gear damaged.
B	Is the battery fully charged and terminals clean?	No	<ul style="list-style-type: none"> • Charge or replace battery. • Clean terminals.
		Yes	See “ C ”
C	Is the starter motor magnetic switch actuating sound heard?	No	Inspect and repair wiring up to magnetic switch, key switch, safety relay magnetic switch assembly and electrical connections as necessary.
		Yes	See “ D ”
D	Does starter motor operate with “ M ” terminal of starter motor connected directly to the battery?	No	Inspect brush and replace if worn. If brushes are not worn, replace armature assembly and/or starter motor assembly.
		Yes	Magnetic switch assembly contact defective. If starter motor becomes wet, replace magnetic switch assembly even if function is normal.
E	Does the starter motor crank the engine at normal speed?	No	See “ B ”
		Yes	See “ A ”

TESTING ELECTRIC STARTER MOTOR OPERATION (STANDARD)

Checking Pinion Projection Length

1. When the pinion is at the projected position, measure the gap (Figure 8-2, (2)) between pinion and pinion stop. This measurement should be made with the pinion pressed back lightly (Figure 8-2, (1)) to take up any play in engagement linkage. See Specifications on page 8-5.

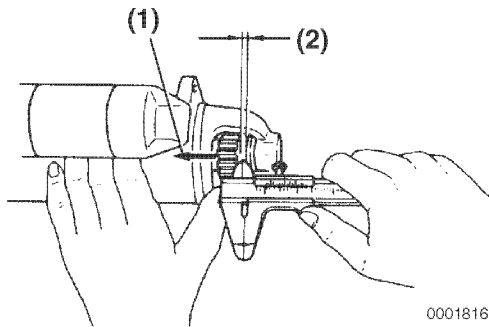

Figure 8-2

2. If the measured dimension (Figure 8-2, (2)) is not within specifications, adjust the dust covers to obtain the standard range. Dust covers (Figure 8-3, (1)) are available in 0.020 in. (0.5 mm) and 0.031 in. (0.8 mm) thicknesses.

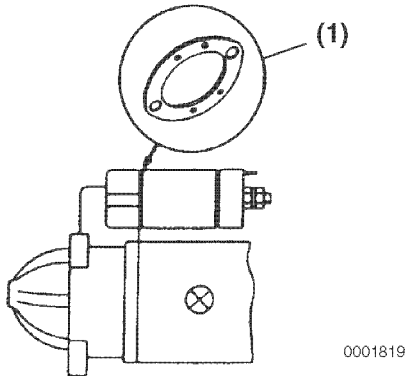

Figure 8-3

3. Check the distance between the flywheel ring gear (Figure 8-4, (2)) and starter motor pinion (Figure 8-4, (1)) in the rest position (mesh clearance) (Figure 8-4, (3)). The clearance must be 0.12 in. - 0.20 in. (3.0 mm - 5.0 mm).

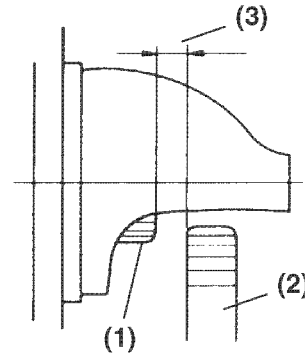

Figure 8-4

STARTER

No-Load Test

Test the characteristics of the starter motor by performing a no load test.

CAUTION

The starter motor can be damaged if operated continuously longer than 10 seconds while performing the no-load test.

0000034en

Secure the starting motor in a vise or other suitable fixture.

1. Connect an ammeter (**Figure 8-5, (1)**) in series between the battery positive (+) terminal (**Figure 8-5, (2)**) and the main positive (+) terminal (**Figure 8-5, (3)**) on the starter motor.

Note: The ammeter and all wire leads used in this test must have a capacity equal to or greater than the amperage draw specification for the starter motor being tested.

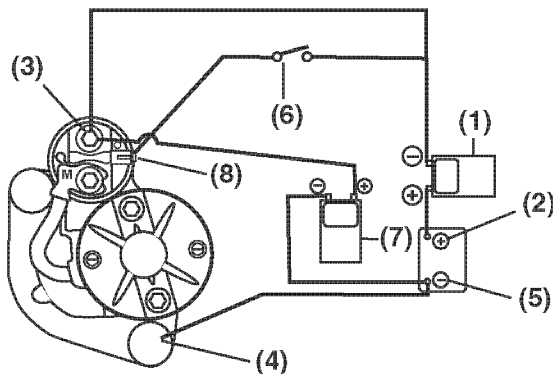

0002127A

Figure 8-5

2. Connect a wire lead between the mounting base of the starter motor (**Figure 8-5, (4)**) and the battery negative terminal (**Figure 8-5, (5)**).
3. Connect a voltmeter (**Figure 8-5, (7)**) to the battery negative (-) terminal (**Figure 8-5, (5)**) and the main positive (+) battery terminal on the starter motor (**Figure 8-5, (3)**).

4. Install a switch (**Figure 8-5, (6)**) in a circuit between the battery positive (+) terminal (**Figure 8-5, (2)**) and the starter solenoid switch terminal (**Figure 8-5, (8)**) on the starter motor.
5. Use a suitable tachometer to monitor the rpm of the starter.
6. Turn the switch to the ON position to energize the solenoid and operate the starter. Monitor the rpm, amperage draw and voltage. See *Specifications on page 8-5* for the appropriate starter motor test specifications.

ELECTRIC STARTER MOTOR (STANDARD)

Disassembly of Electric Starter Motor

⚠ WARNING



SHOCK HAZARD!

- **ALWAYS** turn off the battery switch (if equipped) or disconnect the negative battery cable before servicing the electrical system.
- Check the electrical harnesses for cracks, abrasions, and damaged or corroded connectors. **ALWAYS** keep the connectors and terminals clean.
- Failure to comply could result in death or serious injury.

000009en

Note: While starter motor design varies between models, the basic repair procedures are the same. The following procedures are typical and may differ from the starter being serviced.

1. Disconnect the battery, negative (-) cable first.
2. Remove the wire from the solenoid switch. Remove the solenoid switch mounting bolt.
3. Remove the solenoid switch and dust covers (**Figure 8-6, (1)**).
4. Disconnect the solenoid plunger from the shift lever.

5. Remove the torsion spring (for reduction-type starter motor only) and pull the torsion spring out from the solenoid switch.

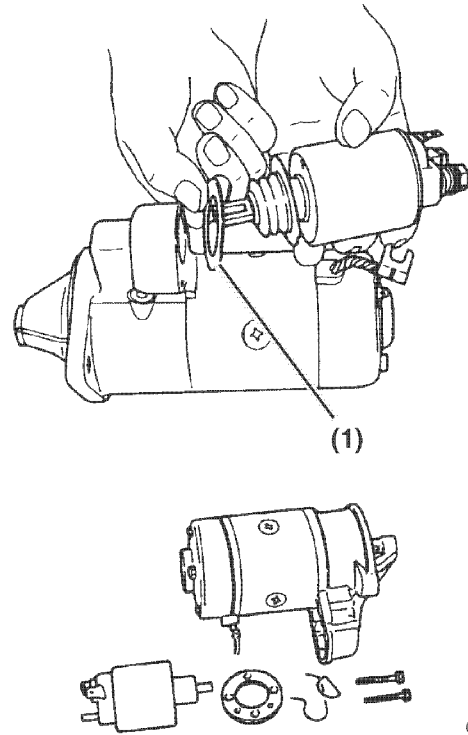

Figure 8-6

6. Remove the rear dust cover (**Figure 8-7, (1)**).
7. Remove the E-ring, and remove the thrust washer (**Figure 8-7**).

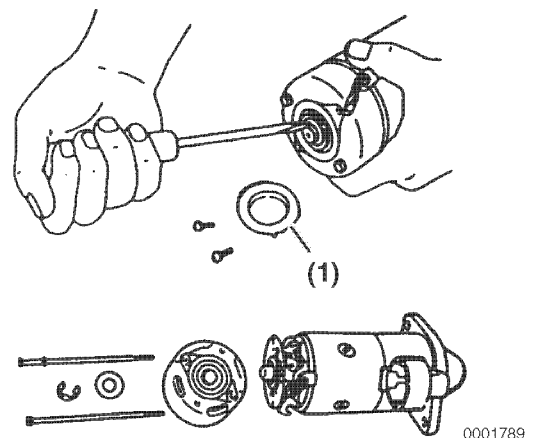

Figure 8-7

STARTER

8. Remove the two through-bolts securing the rear cover and the two screws securing the brush holder.

9. Remove the rear cover.

Note: Make sure that the washer and shim are not damaged.

10. Pull up the brush springs using a brush spring puller (**Figure 8-8**). On the negative (-) side, bring the brush spring into contact with the side of the brush for lifting from the commutator surface. On the positive (+) side, remove the brush from the brush holder assembly.

Note: There are two negative (-) brushes and one positive (+) brush.

11. Remove the brush holder assembly.

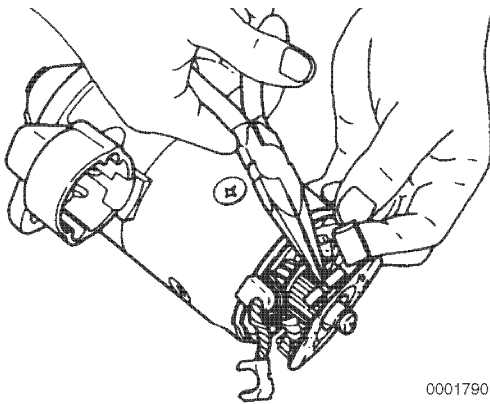

Figure 8-8

12. Pull off the field assembly from the armature assembly (**Figure 8-9**).

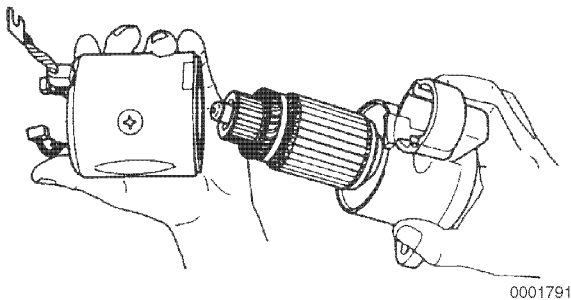

Figure 8-9

13. Pull out the armature assembly from the gear housing (**Figure 8-10**).

14. Remove the shift lever.

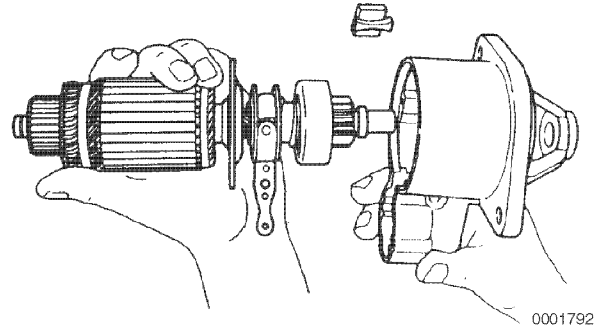

Figure 8-10

15. Pull down the pinion stop (**Figure 8-11, (1)**) to expose the retaining ring. Using a flat-blade screwdriver, remove the retaining ring (**Figure 8-11, (2)**) from the pinion shaft.

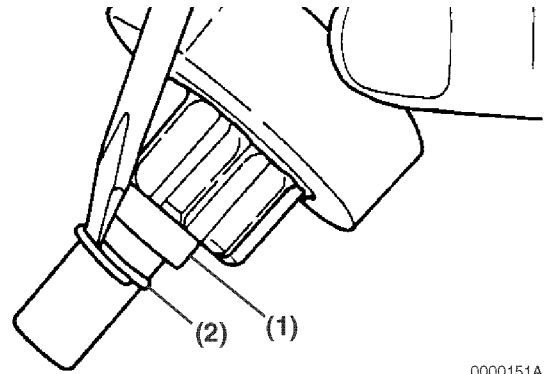

Figure 8-11

16. Remove the pinion stop, return spring (if equipped) and pinion clutch assembly from the pinion shaft (**Figure 8-12**).

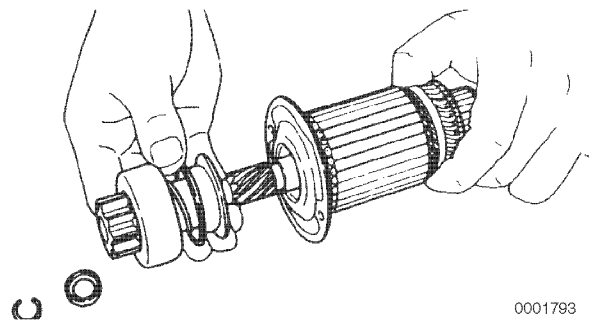

Figure 8-12

Inspection and Testing of Electric Starter Motor Components

Armature

Commutator Surface Inspection

If the commutator surface is rough, polish the surface with a #500 to #600 emery cloth (Figure 8-13).

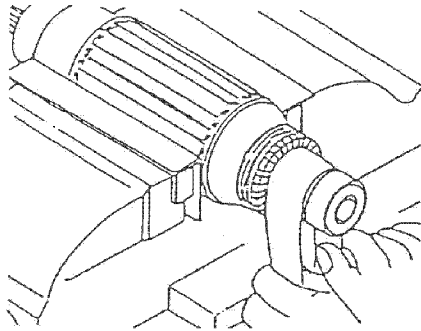

0000117

Figure 8-13

Measure Commutator Outside Diameter

Measure the commutator outside diameter (Figure 8-14). Replace the armature if the measurement is less than the limit.

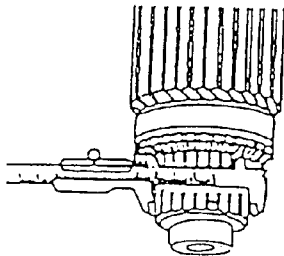

0000113

Figure 8-14

See Specifications on page 8-5 for the service limit.

Measure Commutator Insulation Depth

Measure the depth of the insulating material (Figure 8-15, (1)) between commutator segments (Figure 8-15, (2)). If the depth measures less than the limit, use a hacksaw blade (Figure 8-15, (3)) to remove the insulating material until the depth is within the limit.

A normal commutator condition is indicated in (Figure 8-15, (4)). An abnormal commutator condition is indicated in (Figure 8-15, (5)).

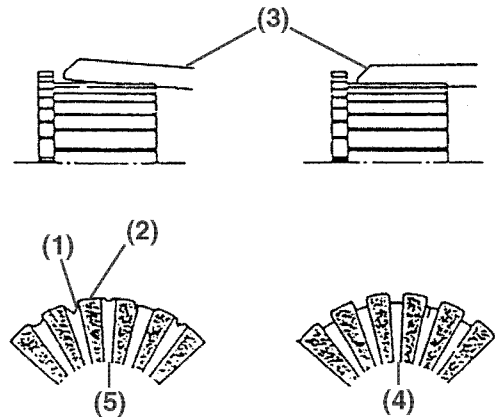

0000118

Figure 8-15

See Specifications on page 8-5 for the service limit.

STARTER

Armature Coil Continuity Test

Check for continuity between the commutator segments using a multimeter (**Figure 8-16**). The multimeter should indicate continuity.

If the multimeter does not indicate continuity, replace the armature.

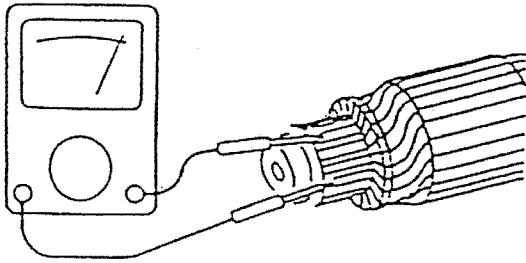

0000114

Figure 8-16

Armature Coil Insulation Test

Check for continuity between a commutator segment and the shaft or armature using a multimeter (**Figure 8-17**). The multimeter should not indicate continuity.

If the multimeter indicates continuity, replace the armature.

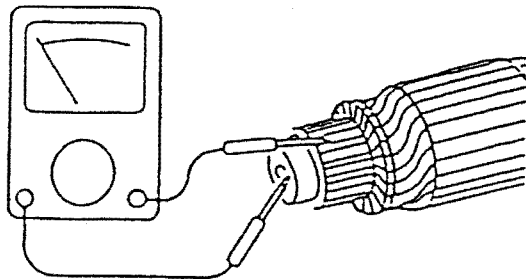

0000115

Figure 8-17

Measure Armature and Commutator Run-Out

Use a dial indicator to measure the armature core runout and the commutator runout (**Figure 8-18**). Replace the armature if either of the measurements is not within specifications.

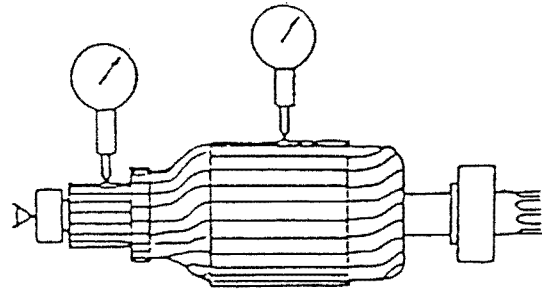

0000116

Figure 8-18

See Specifications on page 8-5 for the service limit.

Field Coil

Field Coil Continuity Test

Check for continuity between the field coil terminals using a multimeter (**Figure 8-19**). The multimeter should indicate continuity.

If the multimeter does not indicate continuity, replace the field coil assembly.

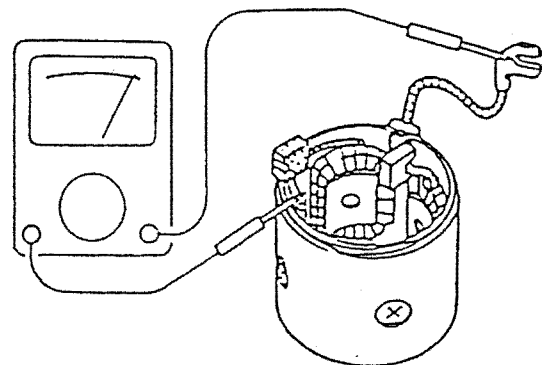

0000119

Figure 8-19

Field Coil Insulation Test

Check for continuity between either field coil terminal and the yoke using a multimeter (**Figure 8-20**). The multimeter should not indicate continuity.

If the multimeter indicates continuity, replace the field coil assembly.

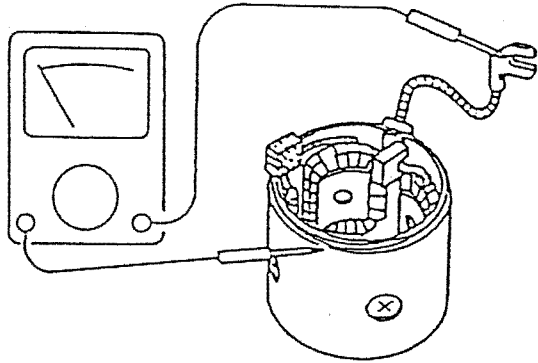

0000120

Figure 8-20

Measure Brush Length

Measure the length of the brush (**Figure 8-21**). Replace the brush if the length is less than the limit.

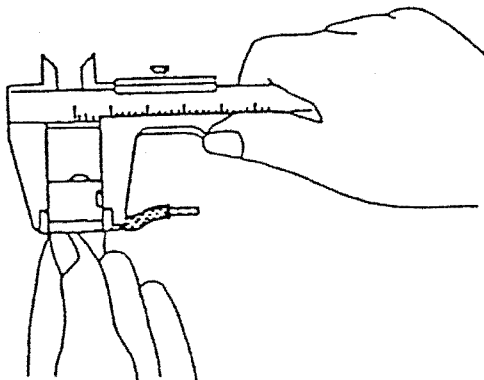

0000121

Figure 8-21

See Specifications on page 8-5 for the service limit.

Brush Holder

Brush Holder Insulation Test

Check for continuity between each brush holder and the base using a multimeter (**Figure 8-22**). The multimeter should not indicate continuity.

If the multimeter indicates continuity, replace the brush holder.

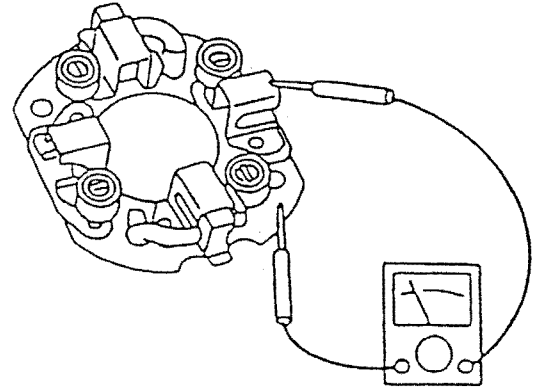

0000122

Figure 8-22

Brush Spring Test

Test the spring force for each brush spring (**Figure 8-23**). Replace the brush spring if the force is not within the range.

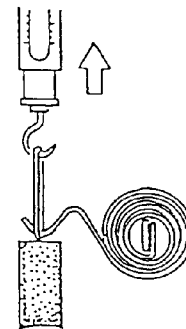

0000123

Figure 8-23

See Specifications on page 8-5 for the service limit.

STARTER

Solenoid Switch

If the starter motor becomes wet, replace the solenoid switch even if the solenoid switch assembly function is normal.

Shunt Coil Continuity Test

Check for continuity between the "S" terminal and the switch body using a multimeter (**Figure 8-24**). The multimeter should indicate continuity.

If the multimeter does not indicate continuity, replace the solenoid switch.

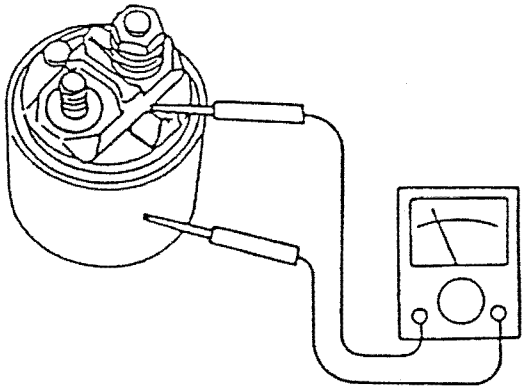

0000124

Figure 8-24

Series Coil Continuity Test

Check for continuity between the "S" and "M" terminals using a multimeter (**Figure 8-25**). The multimeter should indicate continuity.

If the multimeter does not indicate continuity, replace the solenoid switch.

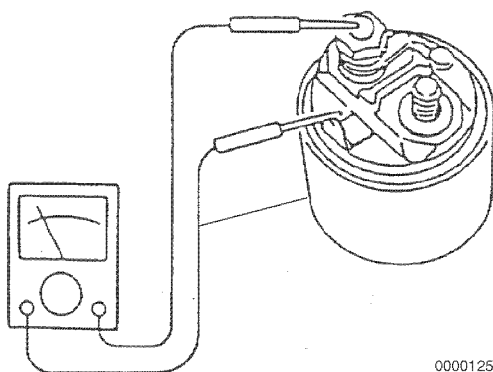

0000125

Figure 8-25

Coil Resistance Test

See *Specifications on page 8-5* for the service limit.

Contact Continuity Test

Depress the plunger at the bottom of the solenoid switch. Check for continuity between the "B" and "M" terminals using a multimeter (**Figure 8-26**). The multimeter should indicate continuity.

If the multimeter does not indicate continuity, replace the solenoid switch.

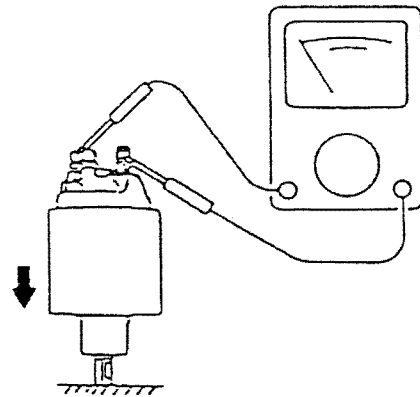

0000126

Figure 8-26

Measure Brush Length

Measure the length of the brush (**Figure 8-27**). Replace the brush if the length is less than the limit.

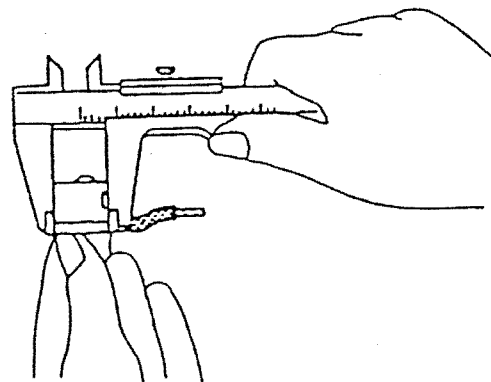

0000121

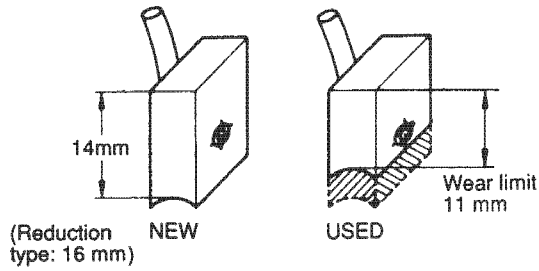

Figure 8-27

Brush Appearance and Brush Movement in Brush Holder

If the outside of the brush is damaged, replace it. If the movement of the brushes in the brush holder is hampered because the holder is rusted, repair or replace the holder.

Pinion

Pinion Teeth Inspection

Inspect the pinion teeth and replace the pinion if the teeth are worn or damaged.

Pinion Clutch Assembly Inspection

Manually rotate the pinion clutch assembly in the drive direction. It should rotate freely in the drive direction and be locked in the opposite direction (**Figure 8-28**). Replace the pinion clutch assembly if the results are different.

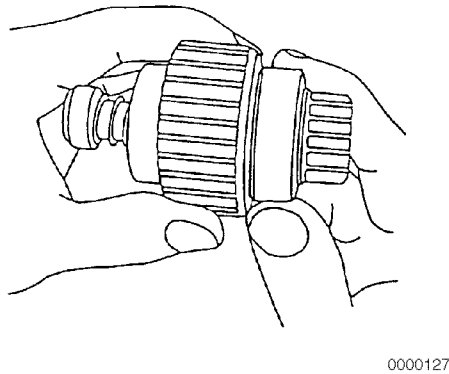

Figure 8-28

Slide the pinion clutch assembly on the shaft. It should slide smoothly on the shaft (**Figure 8-29**). Rust, too much grease or damage could prevent the pinion clutch from sliding smoothly. If the pinion clutch assembly does not slide smoothly, clean the shaft and pinion clutch assembly or replace the damaged component.

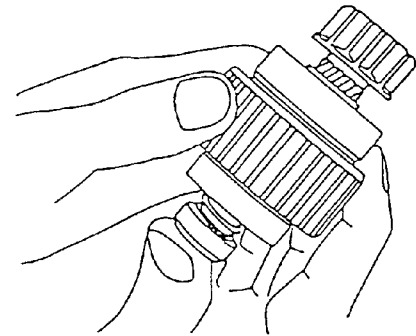

Figure 8-29

Pinion Spring Inspection

Inspect the pinion spring and replace if the spring is faulty.

Reassembly of Electric Starter Motor

1. Lightly grease pinion shaft with appropriate starter bendix grease (obtain locally).
2. Install the pinion assembly onto the shaft.
3. Install the retaining ring in groove in the shaft. Slide the pinion stop over the retaining ring (**Figure 8-30**).

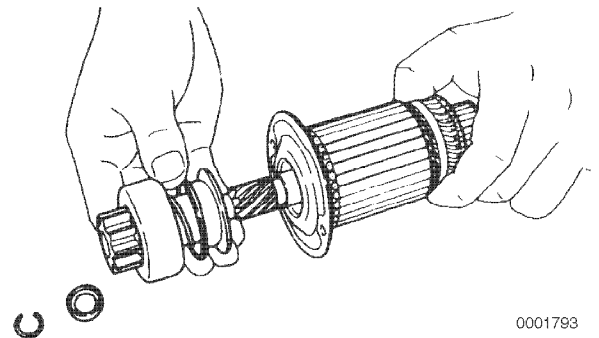

Figure 8-30

STARTER

4. Apply a small amount of high temperature lithium grease (obtain locally) to the sliding portions of the shift lever. Install the shift lever. Be sure the shift lever properly engages the pinion.
5. Install the armature and pinion assembly into the pinion housing (**Figure 8-31**).

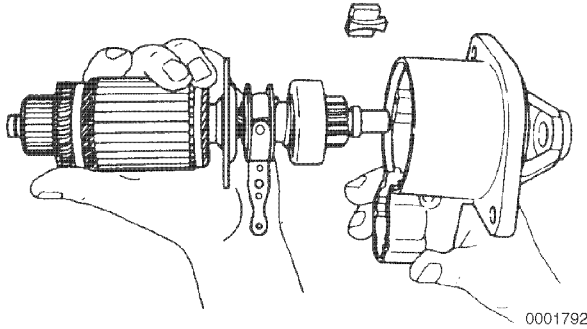

Figure 8-31

6. Install the field assembly over the armature assembly and align to the pinion housing (**Figure 8-32**).

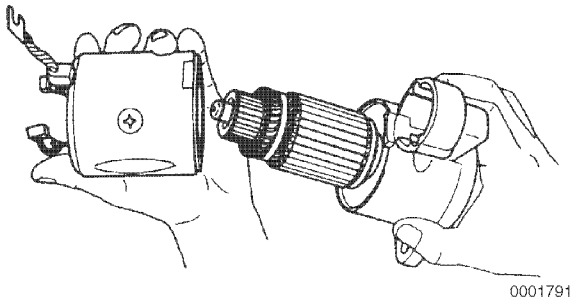

Figure 8-32

7. Install the brush holder assembly to the armature assembly.
8. Position the brush springs in brush holders. Install the brushes in the brush holders. Reversing the brushes will cause the starter motor to turn backwards (**Figure 8-33**).

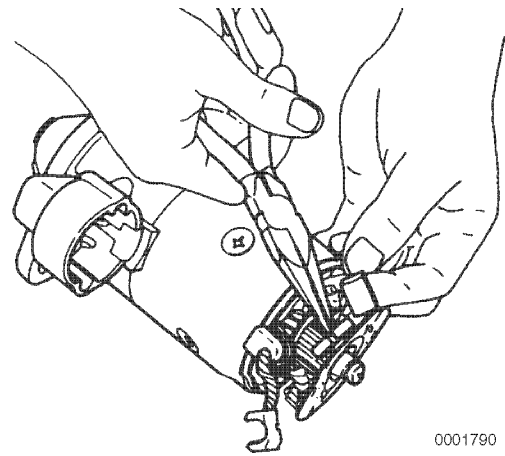

Figure 8-33

9. Install the rear cover.
10. Install and tighten the two through-bolts securely.
11. Install the thrust washer and E-ring.
12. Install the rear dust cover (**Figure 8-34, (1)**).

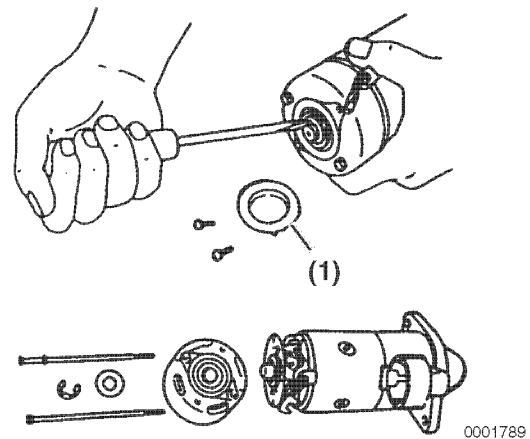

Figure 8-34

13. Apply a light coat of lithium grease to the surface of the plunger and the hole that engages the shift lever.
14. Install the plunger into the solenoid switch. Install the original dust covers (**Figure 8-35, (1)**) and the return spring if equipped.

15. Install the solenoid switch assembly. Be sure the plunger properly engages the shift lever.

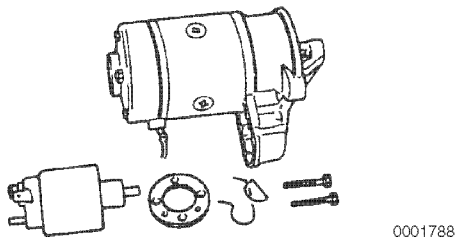
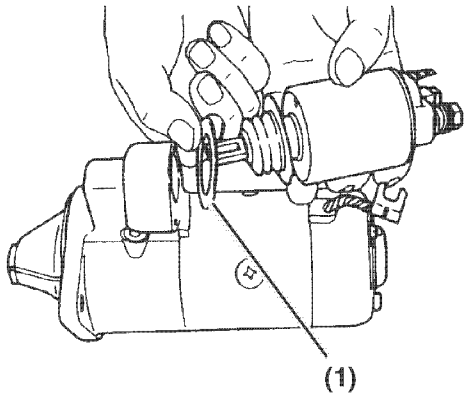
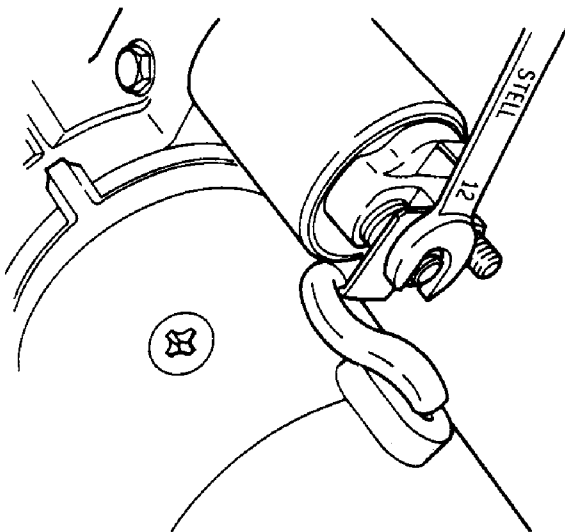

Figure 8-35

16. Connect the wire to the solenoid switch assembly. Tighten the nut (**Figure 8-36**). Install the cover over the connection.



000013:

Figure 8-36

RECOIL STARTER

Disassembly of Recoil Starter

1. Remove the recoil starter assembly from the engine.

Note: Model L100N does not have a notch in the reel. The reel has sufficient clearance to allow the rope to move freely between the reel and starter housing.

2. Pull the starter rope out approximately 12 in. (30 cm) until the notch on the reel lines up with the starter rope. Hold the reel and use a screwdriver to pull the starter rope up (Figure 8-37, (1)).

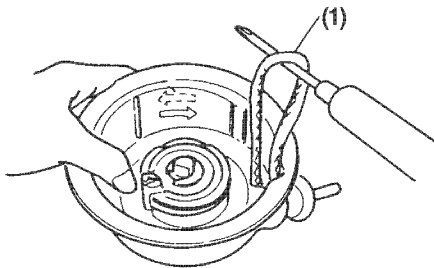
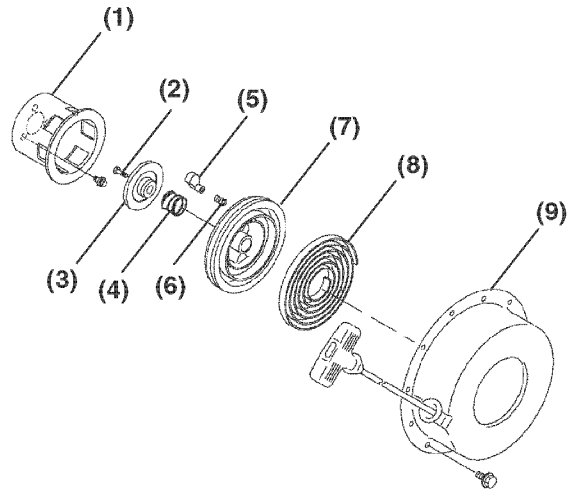

Figure 8-37

3. Allow the reel to slowly rotate backward until it stops. Remove the starter handle.
4. **Models L48N and L70N:** Remove the bolt (Figure 8-38, (2)).

Model L100N: Remove retaining ring, washer and nylon washer (Figure 8-39, (2, 3 and 4)).

L48N and L70N



- | | |
|---------------------|---------------------------|
| 1 – Pulley | 6 – Ratchet Return Spring |
| 2 – Bolt | 7 – Rope Reel |
| 3 – Ratchet Cover | 8 – Recoil Spring |
| 4 – Friction Spring | 9 – Recoil Housing |
| 5 – Ratchet Pawl | |

Figure 8-38

L100N

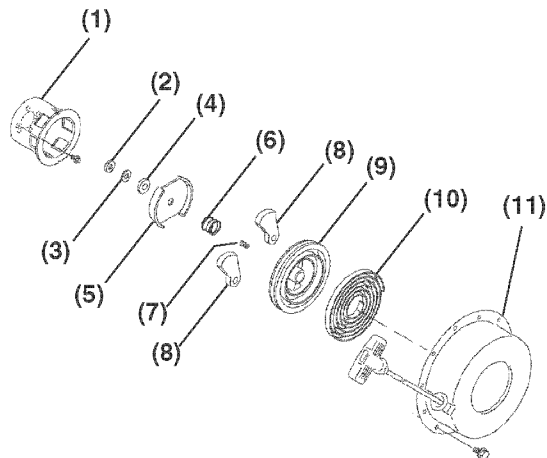

- | | |
|---------------------|---------------------------|
| 1 – Pulley | 7 – Ratchet Return Spring |
| 2 – Retaining Ring | 8 – Ratchet Pawls |
| 3 – Washer | 9 – Rope Reel |
| 4 – Nylon Washer | 10 – Recoil Spring |
| 5 – Ratchet Cover | 11 – Recoil Housing |
| 6 – Friction Spring | |

Figure 8-39

5. Remove the ratchet cover and friction spring.

- Remove the ratchet pawl and ratchet return spring.

⚠ CAUTION

<p>FLYING OBJECT HAZARD!</p> <p>The starter spring is under considerable tension when installing or removing it from the recoil housing and can unexpectedly come out of the housing.</p> <ul style="list-style-type: none"> • ALWAYS wear gloves and safety glasses when repairing the recoil starter. • Failure to comply may result in minor or moderate injury. <p style="text-align: right; font-size: small;">0000030en</p>

IMPORTANT

If the reel is removed too quickly, the spring may unexpectedly come out of the housing.

- Carefully remove the reel (**Figure 8-40, (3)**) from the starter housing (**Figure 8-40, (1)**) while turning it gently left and right to disconnect the boss from the spring (**Figure 8-40, (2)**).

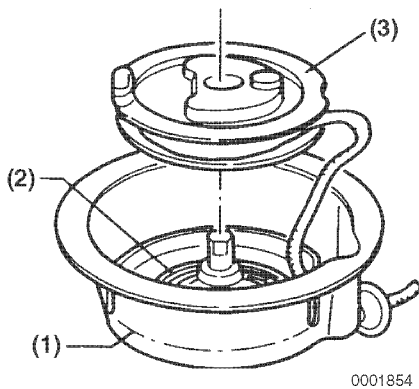

Figure 8-40

- Carefully remove the recoil spring by winding it out of the housing.

Reassembly of Recoil Starter

⚠ CAUTION

<p>FLYING OBJECT HAZARD!</p> <p>The starter spring is under considerable tension when installing or removing it from the recoil housing and can unexpectedly come out of the housing.</p> <ul style="list-style-type: none"> • ALWAYS wear gloves and safety glasses when repairing the recoil starter. • Failure to comply may result in minor or moderate injury. <p style="text-align: right; font-size: small;">0000030en</p>

CAUTION
<p>NEVER allow the recoil handle to snap back against the engine. Return the handle to the starting position gently to prevent damage to the starter.</p> <p style="text-align: right; font-size: small;">0000066en</p>

- Securely hook the spring end to the starter housing (**Figure 8-41, (1)**). Install the recoil spring by carefully winding it into the housing as shown (**Figure 8-41, (5)**).
- Adjust the shape of the inner end (**Figure 8-41, (2)**) of the spring so it is about 0.157 in (4 mm) (**Figure 8-41, (4)**) from the starter spindle (**Figure 8-41, (3)**).

STARTER

Note: Approximately 0.390 in. (10 mm) of the length of the inner end of the spring can be reshaped with pliers.

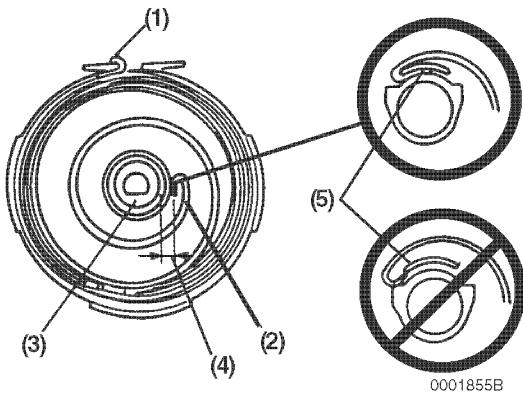

Figure 8-41

3. Lightly lubricate the spindle with lithium-based multipurpose grease (**Figure 8-41, (3)**).
4. Wind the starter rope 2-1/2 turns around the reel in the direction shown (**Figure 8-42**).

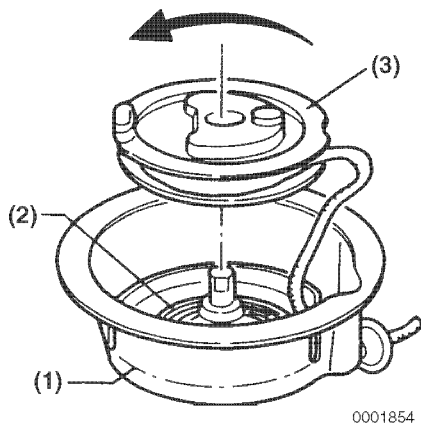
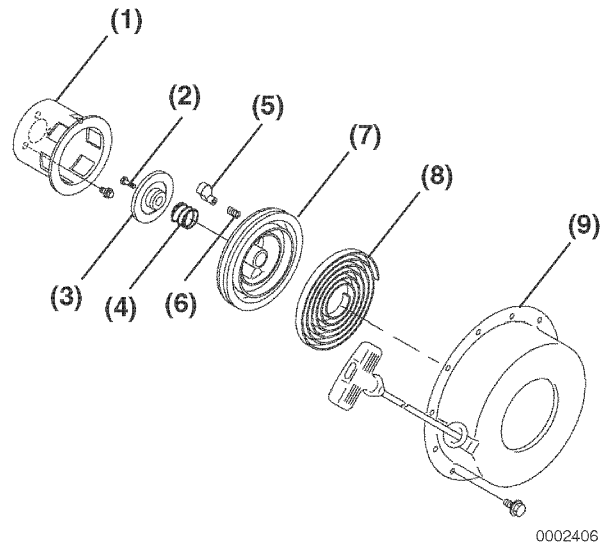

Figure 8-42

5. Place the reel (**Figure 8-42, (3)**) into the housing (**Figure 8-42, (1)**). Be sure the boss (**Figure 8-41, (5)**) on the reel (**Figure 8-41, (2)**) engages the spring inner hook.
6. Thread the starter rope through the hole and tie a temporary knot to prevent the rope from being pulled back into the housing. Allow the reel to slowly rewind the rope until the knot is against the housing.

7. Install the ratchet, ratchet spring, friction spring and ratchet guide.
8. **Models L48N and L70N:** Install and tighten the bolt (**Figure 8-43, (2)**).



- | | |
|---------------------|---------------------------|
| 1 – Pulley | 6 – Ratchet Return Spring |
| 2 – Bolt | 7 – Rope Reel |
| 3 – Ratchet Cover | 8 – Recoil Spring |
| 4 – Friction Spring | 9 – Recoil Housing |
| 5 – Ratchet Pawl | |

Figure 8-43

9. **Model L100N:** Install the nylon washer, flat washer and retaining ring (Figure 8-44, (4, 3, 2)).

Note: Tighten the retaining ring using pliers.

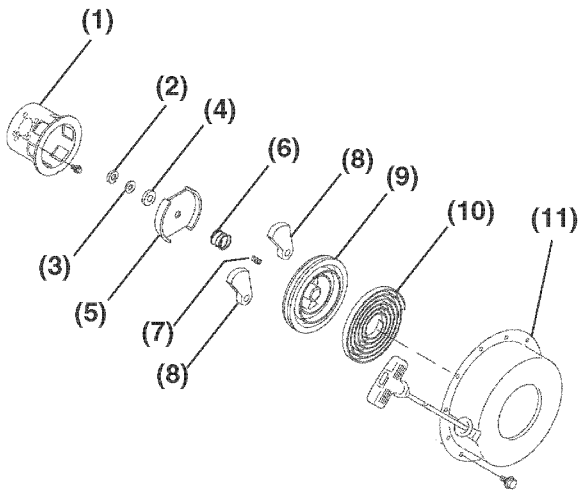

- | | |
|---------------------|---------------------------|
| 1 – Pulley | 7 – Ratchet Return Spring |
| 2 – Retaining Ring | 8 – Ratchet Pawls |
| 3 – Washer | 9 – Rope Reel |
| 4 – Nylon Washer | 10 – Recoil Spring |
| 5 – Ratchet Guide | 11 – Recoil Housing |
| 6 – Friction Spring | |

Figure 8-44

Note: Model L100N does not have a notch in the reel. The reel has sufficient clearance to allow the rope to move freely between the reel and starter housing.

10. Wind the reel four turns in the direction shown (Figure 8-45) while holding the rope in the notch of the reel.

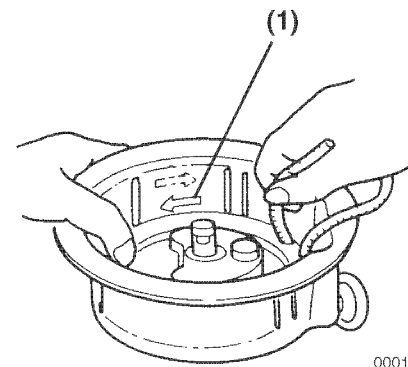

0001856

Figure 8-45

11. Install the handle and remove the temporary knot in the rope.

IMPORTANT

Perform the following checks before operation

12. Pull the starter rope part way out two or three times.
- If the resistance is too tight, make sure the parts are reassembled correctly.
 - If the ratchet does not move, check the friction spring.
13. Pull the starter rope out completely and allow the rope to return slowly.
- If the starter rope does not come out of the reel completely, the return spring is wound too tightly. Remove one to two turns of tension from the rope.
 - If the starter rope returns slowly or does not return completely, rewind the starter rope one turn.

This Page Intentionally Left Blank

Section 9



CHARGING SYSTEM



	Page
Before You Begin Servicing	9-3
Introduction.....	9-5
Specifications	9-5
General Specifications.....	9-5
Unregulated Output Test Specifications	9-5
Regulated Output Test Specifications	9-6
Special Torque Specifications	9-6
Special Service Tools.....	9-6
Measuring Instruments.....	9-7
Charging System Operation	9-7
Charging System Wiring Diagrams	9-8
12 V - 3 A and 12 V - 15 A System.....	9-8
12 V - 1.7 A System.....	9-9
12 V - 1 A System.....	9-9
12 V - 3 A and 12 V - 15 A with Intake Air Heater and Timer ..	9-10
Charging System Components	9-11
Testing of Charging System and Components.....	9-12
Testing Regulated Output.....	9-12
Testing Unregulated Output	9-12
Testing Stator Coil Continuity	9-13
Testing Stator Coil Short-to-Ground	9-13
Testing of Regulator / Rectifier	9-14
Testing of Rectifier.....	9-15
Stator.....	9-16
Removal of Stator.....	9-16
Installation of Stator.....	9-17



This Page Intentionally Left Blank

BEFORE YOU BEGIN SERVICING

Before performing any service procedures within this section, read the following safety information and review the *Safety* section on page 3-1.

 WARNING

<p>ENTANGLEMENT HAZARD!</p> <ul style="list-style-type: none"> • ALWAYS stop the engine before you begin to service it. • NEVER leave the key in the key switch when you are servicing the engine. Someone may accidentally start the engine and not realize you are servicing it. • Failure to comply could result in death or serious injury.
0000010en

 WARNING

<p>SHOCK HAZARD!</p> <ul style="list-style-type: none"> • ALWAYS turn off the battery switch (if equipped) or disconnect the negative battery cable before servicing the electrical system. • Check the electrical harnesses for cracks, abrasions, and damaged or corroded connectors. ALWAYS keep the connectors and terminals clean. • Failure to comply could result in death or serious injury.
0000009en

 WARNING

<p>FUME / BURN HAZARD!</p> <ul style="list-style-type: none"> • ALWAYS read and follow safety related precautions found on containers of hazardous substances like parts cleaners, primers, sealants and sealant removers. • Failure to comply could result in death or serious injury.
0000014en

WARNING



BURN HAZARD!

- NEVER touch hot engine surfaces such as the muffler, exhaust pipe, turbocharger (if equipped) and engine block during operation and shortly after you shut the engine down. These surfaces are extremely hot while the engine is operating and could seriously burn you.
- Failure to comply could result in death or serious injury.

0000015en

CAUTION



FLYING OBJECT HAZARD!

- ALWAYS wear eye protection when servicing the engine and when using compressed air or high-pressure water. Dust, flying debris, compressed air, pressurized water or steam may injure your eyes.
- Failure to comply may result in minor or moderate injury.

0000003en

CAUTION

Do not use a high-pressure wash directly on the alternator. Water will damage the alternator and result in inadequate charging.

0000049en

CAUTION

Do not turn the battery switch OFF while the engine is operating. Damage to the alternator will result.

0000038en

CAUTION

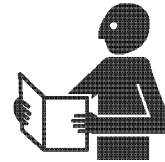

NEVER permit anyone to operate the engine or driven machine without proper training.

- Read and understand this Service Manual before you operate or service the machine to ensure that you follow safe operating practices and maintenance procedures.
- Machine safety signs and labels are additional reminders for safe operating and maintenance techniques.
- See your authorized Yanmar industrial engine dealer or distributor for additional training.

0000002enSM

CAUTION

Agricultural or other chemicals, especially those with a high sulfur content, can adhere to the IC regulator. This will corrode the conductor and result in battery over-charging (boiling) and charging malfunctions. Consult Yanmar before using the equipment in such an environment or the warranty is voided.

0000053en

CAUTION

Do not reverse the positive (+) and negative (-) ends of the battery cable. The alternator diode and stator coil will be damaged.

0000050en

INTRODUCTION

This section of the *Service Manual* describes servicing of the charging system/dynamo. Yanmar Part No. 114399-78730 dynamo is used in this section to show the service procedures for the representative dynamo. For specific part detail, see the *Parts Catalog* for the engine you are working on. The term Charging System will be used throughout this manual in reference to the Dynamo.

SPECIFICATIONS

General Specifications

Yanmar Part Number		114399-78730
Type		Rotating Permanent Magnet
Nominal Output		15 A @ 13 V
Revolution Direction		Clockwise or Counterclockwise
Battery Voltage		12 V
Rated rpm		3600 rpm
Grounding Characteristics		Negative (-) Side of Circuit
Regulated Voltage		14.5 ± 0.5 V
Wire Color	Wire Insulation	Green/White and Green/White
	Tube	White

Unregulated Output Test Specifications

Unregulated Output*	
3750 rpm	3220 rpm
45.4 V	39 V

* Values are approximate.

CHARGING SYSTEM

Regulated Output Test Specifications

Regulated Output @ 3600 rpm		Evaluation	Comment
Voltage	Amperage		
14 V or less	2 A or more	Normal	-
	13.5 A or more		
14-15 V	0.2 - 2.0 A*	Normal	-
	0.3 - 13.5 A*		-
15 V or more	2 A or more	Abnormal	Replace faulty regulator / rectifier
	13.5 A or more		
15 V or less	0 A		Faulty wiring, flywheel magnets or regulator / rectifier
Low	Normal		Faulty battery

* Measured value will vary depending on the charge state of the battery.

Special Torque Specifications

Component	Model	Thread Diameter and Pitch	Torque	Lubricating Oil Application (Thread Portion and Seat Surface)	Reference Page
Flywheel Nut	L48N	M16 x 1.5 mm	101.5 - 108.7 lb-ft (137.3 - 147.1 N·m, 14.0 - 15.0 kgf·m)	Applied	-
	L70N	M16 x 1.5 mm	116 - 123.2 lb-ft (156.9 - 166.7 N·m, 16.0 - 17.0 kgf·m)		
	L100N	M18 x 1.5 mm	159 - 166 lb-ft (215.7 - 225.6 N·m, 22.0 - 23.0 kgf·m)		

See *Tightening Torques for Standard Bolts and Nuts* on page 4-18 for standard hardware torque values.

SPECIAL SERVICE TOOLS

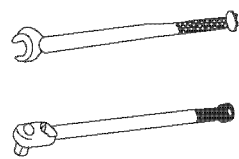
No.	Tool Name	Application	Illustration
1	Torque Wrench (Available Locally)	For tightening nuts and bolts to the specified torque	 0000840

MEASURING INSTRUMENTS

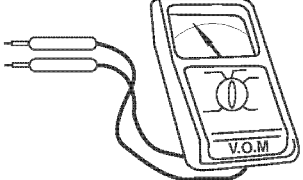
No.	Instrument Name	Application	Illustration
1	Multimeter	Electrical testing of voltage, resistance and amperage.	 <p>0002895</p>

CHARGING SYSTEM OPERATION

The charging system/dynamo consists of a series of permanent magnets that rotate around a stationary stator coil. The magnets are attached to the flywheel which is rotated via the engine crankshaft. The resultant output is an AC (alternating current) signal. The AC is converted to DC (direct current) in the regulator / rectifier. The regulator / rectifier outputs charging DC current to the battery.

Some models incorporate a rectifier only and no regulator. These models output a DC charging current with no regulation.

Some models have only AC lighting capabilities. These models have no rectifier or regulator and output an AC signal only.

CHARGING SYSTEM

CHARGING SYSTEM WIRING DIAGRAMS

12 V - 3 A and 12 V - 15 A System

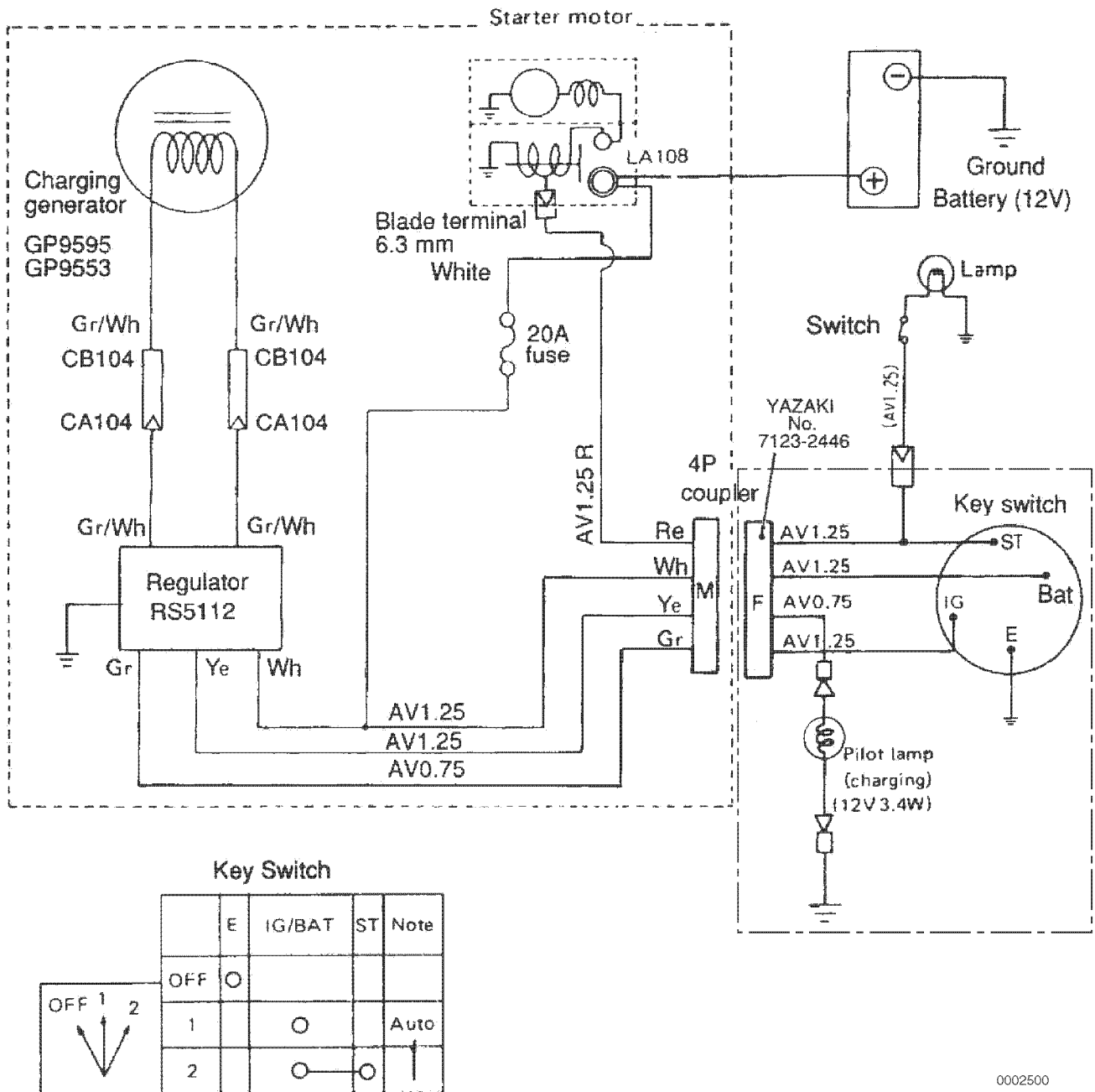

Figure 9-1

12 V - 1.7 A System

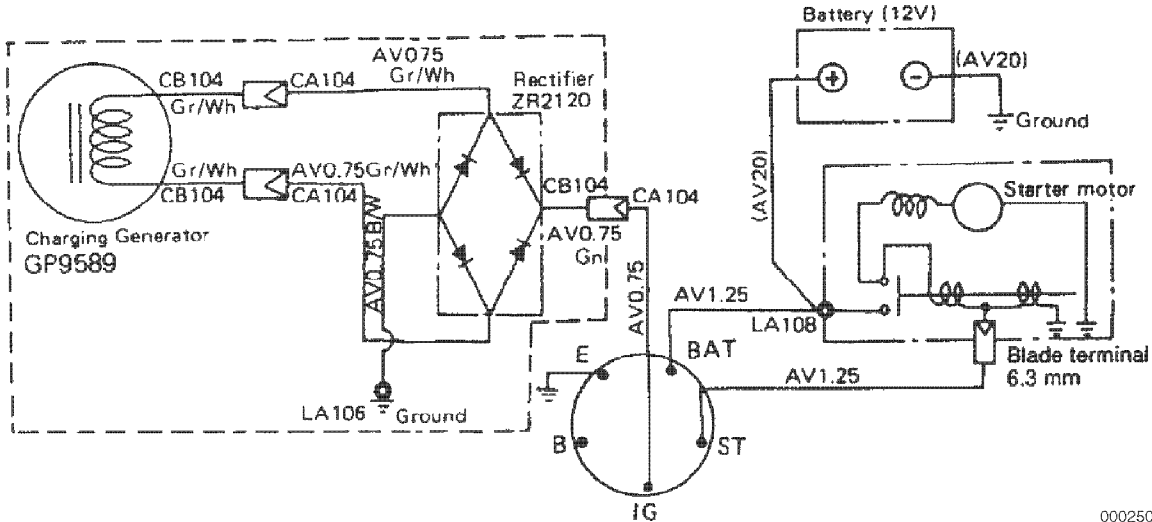

Figure 9-2

0002501

12 V - 1 A System

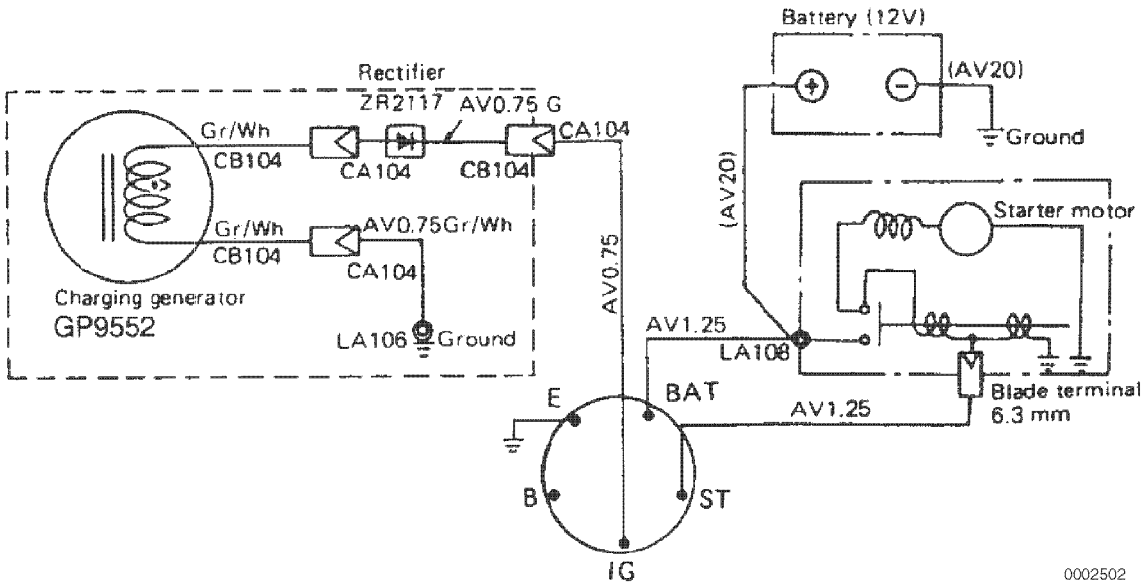
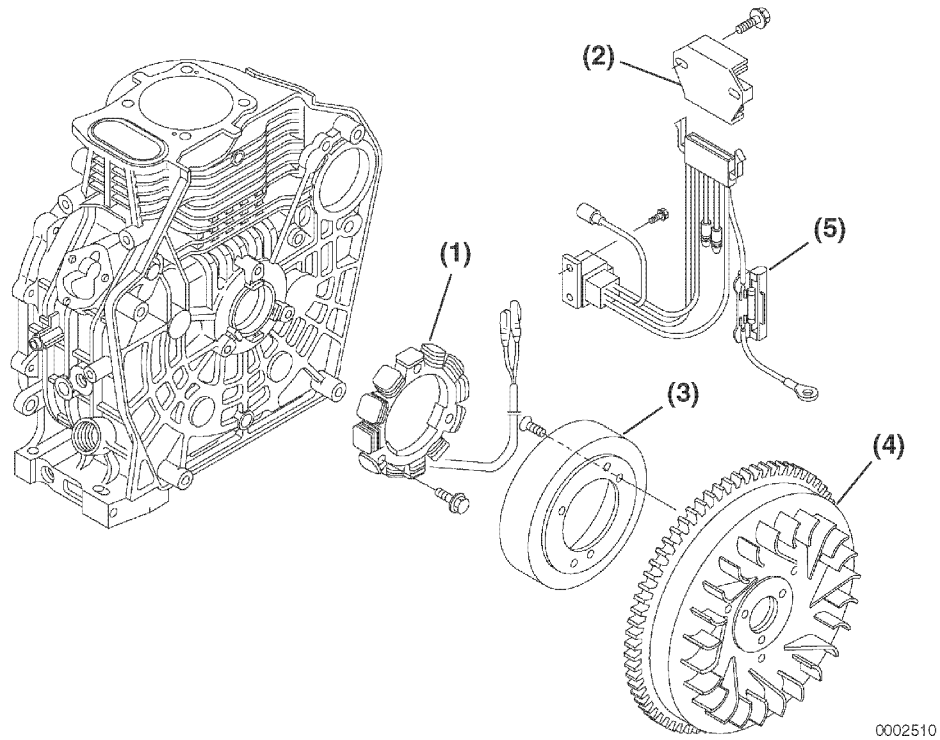

Figure 9-3

0002502

CHARGING SYSTEM COMPONENTS



- 1 – Stator Winding
- 2 – Voltage Regulator / Rectifier
- 3 – Magnet Assembly
- 4 – Flywheel
- 5 – 20 A Fuse*

* Fuse is not used with all systems.

Figure 9-5

CHARGING SYSTEM

TESTING OF CHARGING SYSTEM AND COMPONENTS

Use a circuit tester or multimeter to perform the tests in this section.

Testing Regulated Output

1. Use a test voltmeter (**Figure 9-6, (5)**) to test and record the battery (**Figure 9-6, (6)**) voltage with the engine not running.
2. Connect a test ammeter (**Figure 9-6, (4)**) between the regulator white output wire and the battery positive (+) terminal.
3. Start the engine and operate it at normal operating rpm. The charge lamp (if equipped) (**Figure 9-6, (7)**) should glow.
4. Again, check the battery voltage with the engine running.
5. Check the amperage output.

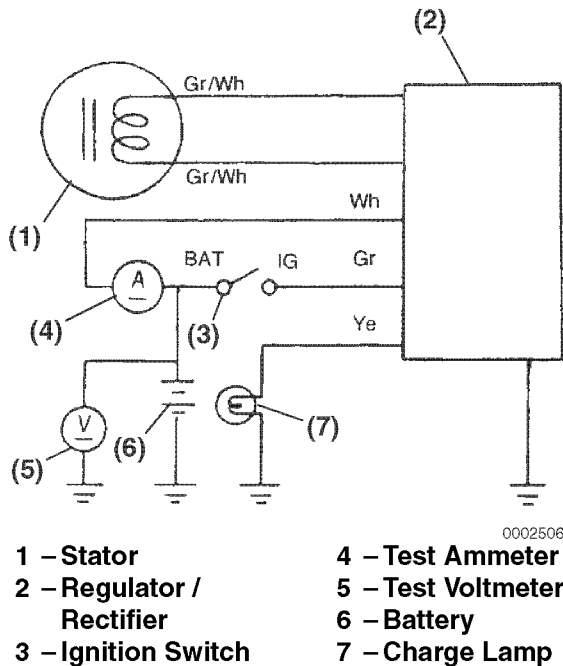

Figure 9-6

Results: The battery voltage must increase and remain within specification with the engine running. The amperage output must be within specification. See *Regulated Output Test Specifications* on page 9-6.

- If results are not correct, test the stator (**Figure 9-6, (1)**) for continuity and shorts to the ground. See *Testing Stator Coil Continuity and Testing Stator Coil Short-to-Ground* on page 9-13.
- Check the charging system wiring.
- Test the ignition switch (**Figure 9-6, (3)**) for continuity between the BAT and IG terminals.
- Test the unregulated output. See *Testing Unregulated Output* on page 9-12.
- If no problems are found in the previous checks, replace the regulator / rectifier (**Figure 9-6, (2)**).

Testing Unregulated Output

1. Disconnect the stator wires from the regulator / rectifier.
2. Connect a test meter to the stator leads. Set the meter to read 100 volts AC (**Figure 9-7**).
3. Start the engine and operate it at normal operating rpm.
4. Check the stator output with the engine running.

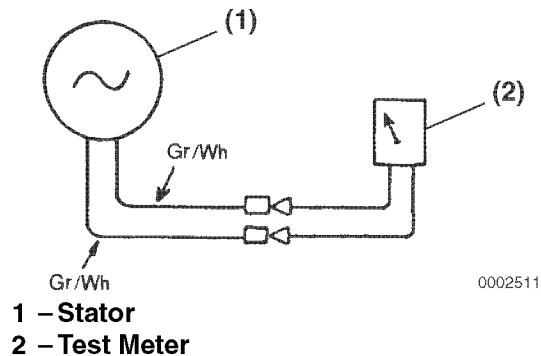

Figure 9-7

Results: The meter reading must be within specification. See *Unregulated Output Test Specifications* on page 9-5.

- If results are not correct, test the stator for continuity and shorts to the ground.
- Check for weak or loose flywheel magnets.

Testing Stator Coil Continuity

1. Disconnect the stator leads from the regulator / rectifier (**Figure 9-8**).
2. Connect one meter lead to each of the stator wire terminals and read the meter.

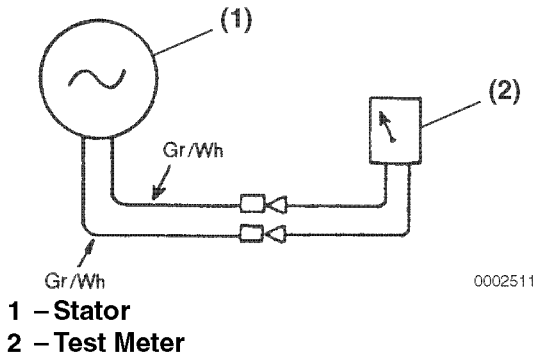

Figure 9-8

Results: The meter reading should indicate continuity. If continuity is not indicated, the windings are open and the stator must be replaced.

Testing Stator Coil Short-to-Ground

1. Disconnect the stator leads from the regulator / rectifier (**Figure 9-9**).
2. Test the continuity between each stator wire terminal and engine ground.

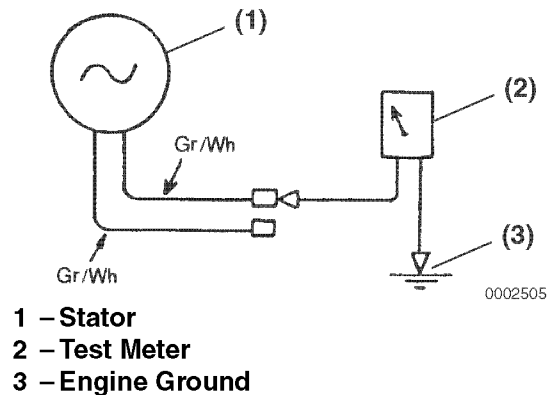

Figure 9-9

Results: The meter reading should be infinity. If the meter reading indicates continuity, the windings are shorted to ground and the stator must be replaced.

CHARGING SYSTEM

Testing of Regulator / Rectifier

1. Disconnect the battery, negative (-) cable first.
2. Disconnect all wiring connectors from the regulator / rectifier.
3. Set the test meter to a range of 1-ohm.
4. Measure the continuity between all terminals.
Also test continuity between each terminal and the case.

Results: Compare the results with the following chart. If the results do not match the chart, replace the regulator / rectifier.

Note: **Yes** = continuity; **No** = no continuity.

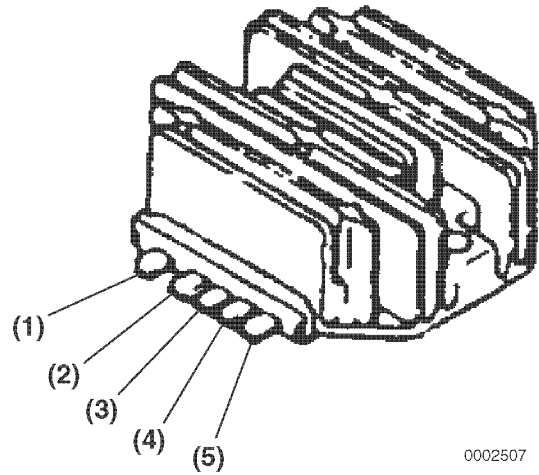

0002507

Figure 9-10

Regulator Number RS5112

		Meter Red Lead					
Meter Black Lead	Terminal Number	1	2	3	4	5	Case
	1	-	no	no	no	no	no
	2	yes	-	no	no	no	no
	3	yes	no	-	no	no	no
	4	no	no	no	-	no	no
	5	yes	yes	yes	no	-	yes
	Case	no	no	no	no	no	-

Regulator Number RS2190

		Meter Red Lead				
Meter Black Lead	Terminal Number	1	2	3	4	5
	1	-	yes	yes	no	yes
	2	no	-	no	no	yes
	3	no	no	-	no	yes
	4	no	no	no	-	no
	5	no	no	no	no	-

Testing of Rectifier

1. Disconnect the battery, negative (-) cable first.
2. Disconnect all wires from the rectifier.
3. Use an ohmmeter or continuity tester to check each diode. Refer to the following graphics and tables for test lead connections.

Results: Compare the results with the appropriate chart. If the results do not match the chart, replace the rectifier.

ZR2117 (Half-Wave Rectifier)

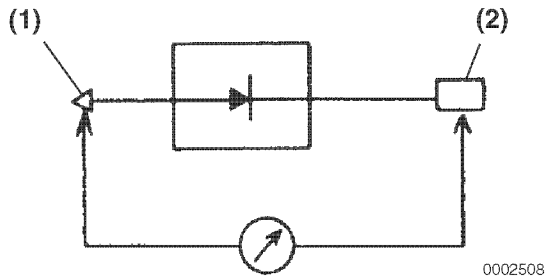

		Meter Red Lead	
		Terminal	
Meter Black Lead	Terminal	1	2
	1	-	no
	2	yes	-

Figure 9-11

ZR2120 (Full-Wave Rectifier)

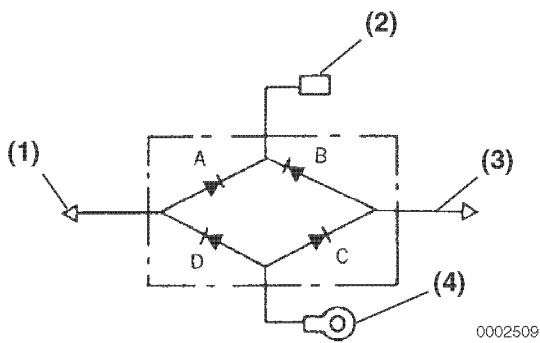

		Meter Red Lead			
		Terminal	1	2	3
Meter Black Lead	Terminal	1	2	3	4
	1	-	yes	-	no
	2	no	-	no	-
	3	-	yes	-	no
4	yes	-	yes	-	

Figure 9-12

STATOR

⚠ WARNING



SHOCK HAZARD!

- **ALWAYS** turn off the battery switch (if equipped) or disconnect the negative battery cable before servicing the electrical system.
- Check the electrical harnesses for cracks, abrasions, and damaged or corroded connectors. **ALWAYS** keep the connectors and terminals clean.
- Failure to comply could result in death or serious injury.

000009en

Removal of Stator

1. Disconnect the battery, negative (-) cable first.
2. Remove the recoil starter and starter pulley. (The recoil starter and cooling fan may be removed as an assembly if the recoil assembly does not require service.)
3. Remove the cooling fan housing (**Figure 9-13**).

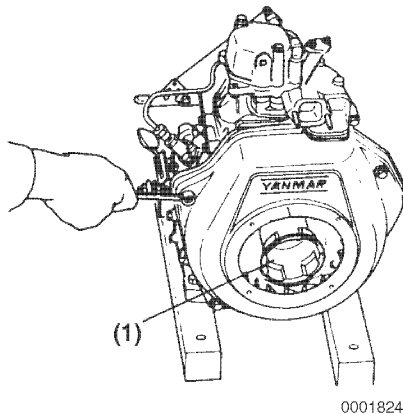

Figure 9-13

4. Remove the starter pulley (**Figure 9-13, (1)**).
5. Use the Yanmar flywheel holding wrench, or a standard strap wrench or ring gear holding tool (if electric start equipped) to hold the flywheel and remove the flywheel nut and washer.
6. Assemble the flywheel puller by threading one nut on each screw (**Figure 9-14, (2)**) all the way to the screw head.
7. Insert each screw through the puller plate and thread a second nut on each screw on other side of puller plate.
8. Install the flywheel puller plate to flywheel with the three puller screw and nut assemblies, threading the screws into flywheel at least 0.5 in. (13 mm).
9. Thread down the lower nuts to the flywheel to keep each screw from moving.
10. Thread the upper nuts evenly to the plate keeping the flywheel puller plate parallel to flywheel.

Note: Support flywheel lightly to prevent flywheel damage as flywheel may “pop” off taper on crankshaft suddenly when using flywheel puller.

11. Tighten each upper nut (**Figure 9-14, (1)**) evenly in a cross pattern to apply tension to flywheel, keeping puller plate parallel to flywheel. Alternately continue to tighten upper nuts until flywheel comes loose from crankshaft. If necessary, lightly tap on the center of the puller plate to assist in “popping” the flywheel loose from the crankshaft.

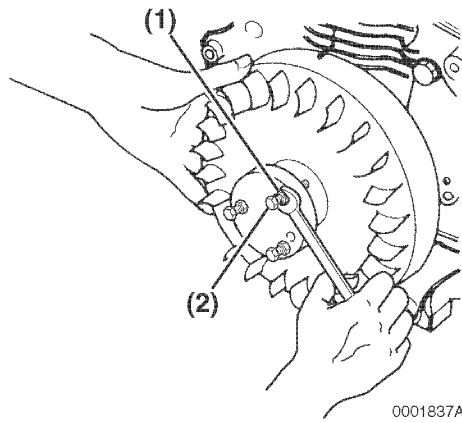

Figure 9-14

Note: Some charging systems use a rectifier only. AC lighting system stators are connected directly to the load and have neither a rectifier nor regulator / rectifier.

12. Disconnect the stator leads from the regulator / rectifier. Remove any wire retainer clamps.
13. Remove the three M6 bolts from the stator assembly.
14. Remove the stator assembly and lead retainer (Figure 9-15, (1, 2)).

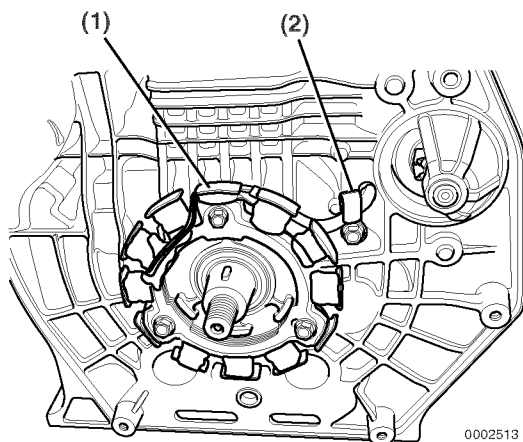

Figure 9-15

15. Inspect the flywheel magnets for damage or looseness. Replace the flywheel and/or magnet assembly if damage or looseness is evident.

Installation of Stator

1. Position the stator on the crankcase. Install three M6 bolts and tighten securely.
2. Route the stator lead to the regulator / rectifier and connect it.
3. Install any wire retainer clamps.
4. Install the flywheel. Install the washer and nut and tighten to specifications. See *Special Torque Specifications* on page 9-6.

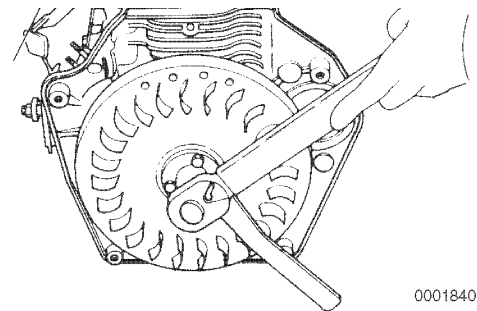

Figure 9-16

5. Install the cooling fan housing, starter pulley and recoil starter.
6. Start the engine. Listen for any unusual sounds from the flywheel area.
7. If equipped, verify that the charge lamp is ON while the engine is operating. If the charge indicator is not ON, repair the problem before operating the engine.

This Page Intentionally Left Blank

Section 10

ELECTRIC WIRING

	Page
Electric Wiring Precautions	10-3
Electrical Wire Resistance.....	10-4
Battery Cable Resistance (If Equipped)	10-5
Electrical Wire Sizes - Voltage Drop	10-6
Conversion of AWG to European Standards.....	10-7

This Page Intentionally Left Blank

ELECTRIC WIRING PRECAUTIONS

Failure to follow these precautions may result in the failure of an electrical component and the loss of warranty coverage on that item as well as related items. Make sure that all users read and understand these precautions.

CAUTION

Do not reverse the positive (+) and negative (-) ends of the battery cable. The alternator diode and stator coil will be damaged.

0000050en

CAUTION

When the battery indicator goes out, it should not come on again. The battery indicator only comes on during operation if the alternator fails. However, if an LED is used in the battery indicator, the LED will shine faintly during normal operation.

0000051en

CAUTION

Make sure that the combined total resistance of the battery cable in both directions between the starter motor and the battery is within the value indicated in the *Battery Cable Resistance chart* in the *Electric Wiring Section* of this manual. The starter motor will malfunction and fail if the resistance is higher than the specified value.

0000057en

CAUTION

Removing the battery cables or the battery while the engine is operating may cause damage to the current limiter depending on the electrical equipment being used. This situation could cause loss of control of output voltage. The continuous high voltage of 23-24 volts (for 5000 rpm dynamo) will damage the current limiter and other electrical equipment.

0000058en

CAUTION

Reversing the battery cable connections at the battery or on the engine will destroy the SCR diode in the current limiter. This will cause the charging system to malfunction and may cause damage to the electrical harnesses.

0000059en

ELECTRIC WIRING

ELECTRICAL WIRE RESISTANCE

AWG	Metric Nominal mm ²	Ohms / Foot Resistance
20	0.5	0.009967
18	0.8	0.006340
16	1.25	0.004359
14	2	0.002685
12	3	0.001704
10	5	0.001073
8	8	0.000707
6	15	0.000421
4	20	0.000270
2	30	0.000158
1	40	0.000130
0 (1/0)	50	0.000103
00 (2/0)	60	0.000087
000 (3/0)	85	0.000066
0000 (4/0)	100	0.000051

Wiring voltage drop should not exceed 5% $[0.05] \times 12 \text{ Volts} = 0.6 \text{ Volts}$.

Voltage Drop = Current [Amps] x Length of Wire [Feet] x Resistance per Foot [Ohms]

Example:

Current draw of 100 Amps x 3 feet of 4 AWG wire

$100 \text{ Amps} \times 3 \text{ Feet} \times 0.000270 = 0.08 \text{ Volts [Voltage Drop]}$

BATTERY CABLE RESISTANCE (IF EQUIPPED)

AWG	mm ²	Maximum Total Battery Cable Length (Positive Cable + Negative Cable + a*) 12 V Starter Motor Output			
		Less Than 2.68 hp (2 kW)		Greater Than 2.68 hp (2 kW)	
		m	ft	m	ft
6	15	1.5	4.75	N/A	N/A
4	20	2.3	7.4	N/A	N/A
2	30	3.8	12.6	2.3	7.5
1	40	4.6	15.3	2.8	9.2
0 (1/0)	50	5.9	19.5	3.5	11.6
00 (2/0)	60	7.0	22.8	4.2	13.7
000(3/0)	85	9.3	30.5	5.6	18.3
0000 (4/0)	100	11.9	39.0	7.1	23.4
00000 (5/0)	125	N/A	N/A	8.3	27.3
000000 (6/0)	150	N/A	N/A	10.1	33.3

Note: Total allowable resistance of the complete battery cable circuit (positive cable + negative cable + a*)
(a*: Resistance (Ω) of a battery switch or other electrical equipment having high resistance)

For starter motors of less than 2.68 hp (2 kW): The total resistance must be less than 0.002 Ω .

For starter motors of greater than 2.68 hp (2 kW): The total resistance must be less than 0.0012 Ω .

ELECTRIC WIRING

ELECTRICAL WIRE SIZES - VOLTAGE DROP

Total current on circuit in amps	Length of conductor from source of current to device and back to source—feet																		
	10	15	20	25	30	40	50	60	70	80	90	100	110	120	130	140	150	160	170
12 Volts	Wire Size (AWG)																		
5	18	16	14	12	12	10	10	10	8	8	8	6	6	6	6	6	6	6	6
10	14	12	10	10	10	8	6	6	6	6	4	4	4	4	2	2	2	2	2
15	12	10	10	8	8	6	6	6	4	4	2	2	2	2	2	1	1	1	1
20	10	10	8	6	6	6	4	4	2	2	2	2	1	1	1	0	0	0	2/0
25	10	8	6	6	6	4	4	2	2	2	1	1	0	0	0	2/0	2/0	2/0	3/0
30	10	8	6	6	4	4	2	2	1	1	0	0	0	2/0	2/0	3/0	3/0	3/0	3/0
40	8	6	6	4	4	2	2	1	0	0	2/0	2/0	3/0	3/0	3/0	4/0	4/0	4/0	4/0
50	6	6	4	4	2	2	1	0	2/0	2/0	3/0	3/0	4/0	4/0	4/0				
60	6	4	4	2	2	1	0	2/0	3/0	3/0	4/0	4/0	4/0						
70	6	4	2	2	1	0	2/0	3/0	3/0	4/0	4/0								
80	6	4	2	2	1	0	3/0	3/0	4/0	4/0									
90	4	2	2	1	0	2/0	3/0	4/0	4/0										
100	4	2	2	1	0	2/0	3/0	4/0											
24 Volts																			
5	18	18	18	16	16	14	12	12	12	10	10	10	10	10	8	8	8	8	8
10	18	16	14	12	12	10	10	10	8	8	8	6	6	6	6	6	6	6	6
15	16	14	12	12	10	10	8	8	6	6	6	6	6	4	4	4	4	4	2
20	14	12	10	10	10	8	6	6	6	6	4	4	4	4	2	2	2	2	2
25	12	12	10	10	8	6	6	6	4	4	4	4	2	2	2	2	2	2	1
30	12	10	10	8	8	6	6	4	4	4	2	2	2	2	2	1	1	1	1
40	10	10	8	6	6	6	4	4	2	2	2	2	1	1	1	0	0	0	2/0
50	10	8	6	6	6	4	4	2	2	2	1	1	0	0	0	2/0	2/0	2/0	3/0
60	10	8	6	6	4	4	2	2	1	1	0	0	0	2/0	2/0	3/0	3/0	3/0	3/0
70	8	6	6	4	4	2	2	1	1	0	0	2/0	2/0	3/0	3/0	3/0	3/0	4/0	4/0
80	8	6	6	4	4	2	2	1	0	0	2/0	2/0	3/0	3/0	3/0	4/0	4/0	4/0	4/0
90	8	6	4	4	2	2	1	0	0	2/0	2/0	3/0	3/0	4/0	4/0	4/0	4/0	4/0	
100	6	6	4	4	2	2	1	0	2/0	2/0	3/0	3/0	4/0	4/0	4/0				

CONVERSION OF AWG TO EUROPEAN STANDARDS

Conductor Size (AWG)	Conductor Diameter (mm)	Conductor Cross-sectional Area (mm ²)
25	0.455	0.163
24	0.511	0.205
23	0.573	0.259
22	0.644	0.325
21	0.723	0.412
20	0.812	0.519
19	0.992	0.653
18	1.024	0.823
17	1.15	1.04
16	1.29	1.31
15	1.45	1.65
14	1.63	2.08
13	1.83	2.63
12	2.05	3.31
11	2.30	4.15
10	2.59	5.27
9	2.91	6.62
8	3.26	8.35
7	3.67	10.6
6	4.11	13.3
5	4.62	16.8
4	5.19	21.2
3	5.83	26.7
2	6.54	33.6
1	7.35	42.4
0 (1/0)	8.25	53.4
00 (2/0)	9.27	67.5
000(3/0)	10.40	85.0
0000 (4/0)	11.68	107.2
00000 (5/0)	13.12	135.1
000000 (6/0)	14.73	170.3
1.1 circular mil (CM) \cong 0.0005067 mm ²		

This Page Intentionally Left Blank

Section 11

TROUBLESHOOTING

	Page
Before You Begin Servicing	11-3
Introduction.....	11-4
Specifications	11-4
Cylinder Compression Pressure.....	11-4
Measuring Instruments.....	11-4
Troubleshooting By Measuring Compression Pressure	11-5
Measuring Compression Pressure	11-5
Low Compression Troubleshooting Chart	11-6
Troubleshooting Quick Reference Charts	11-6

This Page Intentionally Left Blank



BEFORE YOU BEGIN SERVICING

Before performing any service procedures within this section, read the following safety information and review the *Safety* section on page 3-1.

 WARNING	
	
<p>ALWAYS wear SAFETY GLASSES while servicing the engine to prevent possible eye injury.</p>	
<small>0000013en</small>	

 WARNING	
	
<p>FUME / BURN HAZARD!</p> <ul style="list-style-type: none"> • ALWAYS read and follow safety related precautions found on containers of hazardous substances like parts cleaners, primers, sealants and sealant removers. • Failure to comply could result in death or serious injury. 	
<small>0000014en</small>	

 WARNING	
	
<p>ENTANGLEMENT HAZARD!</p> <ul style="list-style-type: none"> • ALWAYS stop the engine before you begin to service it. • NEVER leave the key in the key switch when you are servicing the engine. Someone may accidentally start the engine and not realize you are servicing it. • Failure to comply could result in death or serious injury. 	
<small>0000010en</small>	

 CAUTION	
	
<p>FLYING OBJECT HAZARD!</p> <ul style="list-style-type: none"> • ALWAYS wear eye protection when servicing the engine and when using compressed air or high-pressure water. Dust, flying debris, compressed air, pressurized water or steam may injure your eyes. • Failure to comply may result in minor or moderate injury. 	
<small>0000003en</small>	

TROUBLESHOOTING

INTRODUCTION

This section of the *Service Manual* describes troubleshooting procedures to assist in engine problem diagnosis and repair.

SPECIFICATIONS

Cylinder Compression Pressure

Model	Engine Starting Type	* Standard	* Limit
L48N	Recoil Start	360 psi (2482 kPa, 25 kgf/cm ²)	285 psi (1965 kPa, 20 kgf/cm ²)
	Electric Start	360 psi (2482 kPa, 25 kgf/cm ²)	285 psi (1965 kPa, 20 kgf/cm ²)
L70N	Recoil Start	400 psi (2757 kPa, 28 kgf/cm ²)	320 psi (2206 kPa, 22 kgf/cm ²)
	Electric Start	420 psi (2895 kPa, 30 kgf/cm ²)	335 psi (2309 kPa, 24 kgf/cm ²)
L100N	Recoil Start	440 psi (3033 kPa, 31 kgf/cm ²)	350 psi (2413 kPa, 25 kgf/cm ²)
	Electric Start	460 psi (3171 kPa, 32 kgf/cm ²)	365 psi (2516 kPa, 26 kgf/cm ²)

* Note: All compression values are ± 15 PSI (103 kPa, 1 kgf/cm²)

The compression specifications above were obtained under the following criteria: Engine temperature - cold, Ambient temperature - 68°F (20°C), Engine lube oil - Yanmar 15W-40, Compression adaptor - Kiene C-3086, Compression gauge - Snap-on™ MT33C.

MEASURING INSTRUMENTS

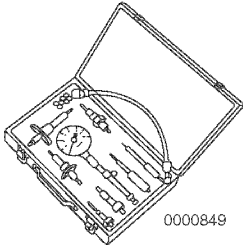
Compression Gauge Kit or Compression Gauge and Compression Adapters (Available Locally)	For measuring compression pressure Yanmar Gauge Set Code No. TOL-97190080	 0000849
---	--	--

TROUBLESHOOTING BY MEASURING COMPRESSION PRESSURE

Compression pressure drop is one of the major causes of increasing blow-by gas (engine oil contamination or increased engine oil consumption as a resultant phenomenon) or starting failure. The compression pressure is affected by the following factors:

- Degree of piston ring wear and the resultant increased end gap
 - ◆ Damaged piston (possibly due to the use of starting fluid such as ether)
- Incorrect intake / exhaust valve clearance
- Poor sealing at the intake / exhaust valve seat due to burned or warped valves
- Gas leak from nozzle gasket or cylinder head gasket
 - ◆ Bent connecting rod

The pressure will drop because of increased parts wear. Pressure drop reduces the durability of the engine.

A pressure drop may also be caused by scored cylinder or piston due to dust entrance from the dirty air cleaner element or worn or broken piston ring.

Measure the compression pressure to determine the condition of the engine.

Measuring Compression Pressure

Note: When measuring cylinder compression, values obtained may vary slightly from the values listed in the *Cylinder Compression Pressure chart on page 11-4* due to varying testing conditions, however should be comparable.

1. With the engine COLD (room temperature), remove the fuel injector (**Figure 11-1, (3)**) from the cylinder head. See *Removal of Fuel Injector on page 7-22*.

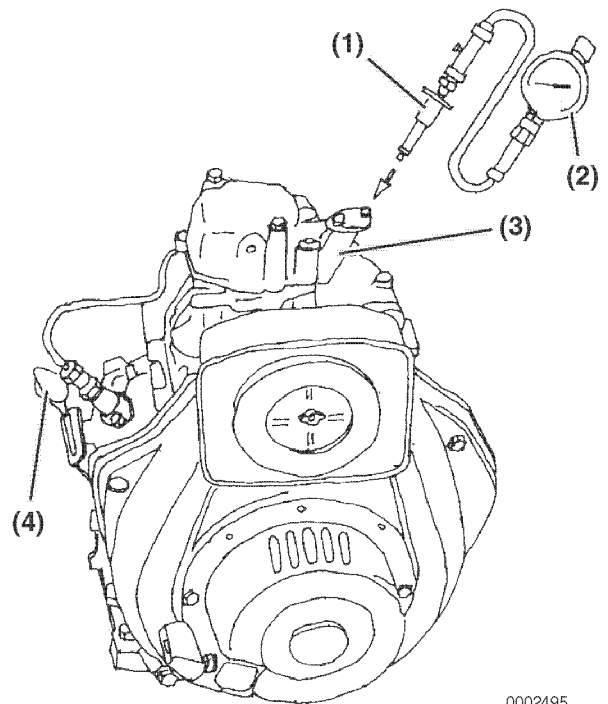

Figure 11-1

2. Crank the engine with the speed control (**Figure 11-1, (4)**) in the stop position (no injection state) 5-6 compression strokes before installing the compression gauge adapter.
3. Install a gasket at the tip end of the compression gauge adapter (**Figure 11-1, (1)**). Install the compression gauge (**Figure 11-1, (2)**) and the compression gauge adapter at the cylinder.
4. Crank the engine using the recoil or electric starter until the compression gauge reading is stabilized and at its maximum.
5. After performing the compression check, remove the compression gauge and compression gauge adapter from the cylinder. Install the fuel injector and high-pressure fuel injection line. See *Installation of the Fuel Injector on page 7-26*.

0002495

TROUBLESHOOTING

Low Compression Troubleshooting Chart

When the measured compression pressure is below the limit value, inspect each part in the chart below for a possible cause.

No.	Item	Cause	Corrective Action
1	Air Cleaner Element	Clogged element	Clean the element.
		Broken element	Replace the element.
		Defect at element seal portion	
2	Compression Release	Misadjusted, damaged or sticking	Repair or replace as necessary.
3	Valve Clearance	Excessive or no clearance	Adjust the valve clearance.
4	Cylinder Head Gasket	Gas leak from gasket	Replace the gasket.
			Retighten the cylinder head bolts to the specified torque.
5	Intake / Exhaust Valve	Warped or burned valves	Replace the intake / exhaust valve.
	Intake / Exhaust Valve	Sticking valve	Replace the intake / exhaust valve.
	Valve Seat	Gas leak due to worn valve seat or foreign matter trapped in valve	Lap the valve seat.
6	Piston Ring	Excessive end gap or broken	Replace piston rings with new.
	Piston	Damaged, scored, or cracked	Replace piston with new.
	Cylinder	Excessive wear or scoring	Perform honing and use oversized piston and rings.
7	Connecting Rod	Bent	Replace with new.

TROUBLESHOOTING QUICK REFERENCE CHARTS

The following charts summarize general trouble symptoms and their causes.

IMPORTANT

If any trouble symptoms occur, take corrective action immediately, to prevent engine damage and or personal injury.

TROUBLESHOOTING CHARTS

Cause	Trouble Symptom																				Corrective Action	Reference Page				
	Starting Problem			Insufficient Engine Output			Poor Exhaust Color		High Knocking Sound During Combustion	Abnormal Engine Sound	Uneven Combustion Sound	Engine Surging		Difficulty in Returning to Low Speed	Excessive Fuel Consumption	Engine Oil				Air Intake			Exhaust Temperature Rise			
	Engine Does Not Start.	Engine Starts But Stops Soon.		Exhaust Color			During Work					During Idling	During Work Operation			Excessive Engine Vibration	Excessive Oil Consumption	Dilution by Diesel Fuel	Oil with Water	Low Oil Pressure				Excessive Blow-by Gas	Pressure Drop	Pressure Rise
		None	Little	Much	Ordinary	White	Black	White																		
Engine System	Improper Intake/Exhaust Valve Clearance	○	○		○					○										○	○	Adjust the Valve Clearance.	See Checking Actual Piston TDC (Top Dead Center) on page 6-36.			
	Compression Leakage from Valve Seat				○	○	○		○					○						○	○	○	Lap the Valve Seat.	See Valve Face and Valve Seat on page 6-26.		
	Intake/Exhaust Valve Seizure	○		○	○	○	○		○		○					○				○	○		Correct or Replace Intake/Exhaust Valve.	See Valves and Valve Guides on page 6-27.		
	Cylinder Head Gasket Blowout				○												○						Replace the Gasket.	See Inspection of Engine Components on page 6-45.		
	Seized or Broken Piston Ring	○		○		○	○		○		○					○	○					○	Replace the Piston Ring.	See Reassembly of Piston, Piston Rings and Connection Rod on page 6-60.		
	Worn Piston Ring, Piston or Cylinder	○		○		○	○									○	○						Perform Honing and Use Oversize Parts.	See Honing and Boring on page 6-52.		
	Seized Crankpin Metal or Bearing	○	○							○		○	○	○								○	Repair or Replace.	See Crankshaft on page 6-48.		
	Improper Arrangement of Piston Ring Gaps		○			○										○							Correct the Ring Joint Positions.	See Reassembly of Piston, Piston Rings and Connection Rod on page 6-60.		
	Reverse Assembly of Piston Rings					○	○									○						○	Reassemble Correctly.	See Reassembly of Piston, Piston Rings and Connection Rod on page 6-60.		
	Worn Crankpin and Journal Bearing				○					○		○	○	○								○	Measure and Replace.	See Crankshaft on page 6-48.		
	Loose Connecting Rod Bolt									○				○								○	Tighten to the Specified Torque.	See Special Torque Specifications on page 6-18.		
	Foreign Matter Trapped in Combustion Chamber	○								○						○						○	Disassemble and Repair.	See Inspection of Engine Components on page 6-45.		
	Worn Intake/Exhaust Valve Guide					○										○						○	Measure and Replace.	See Intake / Exhaust Valves, Guides and Seals on page 6-6.		
	Governor Adjusted Incorrectly		○									○	○	○	○								Make Adjustment.	See Check Engine Speed Control on page 5-20.		
	Improper Open/Close Timing of Intake/Exhaust Valves	○				○	○	○	○	○													Adjust the Valve Clearance.	See Checking Actual Piston TDC (Top Dead Center) on page 6-36.		
Bent Connecting Rod	○	○			○																	Replace Connecting Rod.	See Removal of Engine on page 6-40.			

This Page Intentionally Left Blank

This Page Intentionally Left Blank

Trouble Symptom		Starting Problem			Insufficient Engine Output			Poor Exhaust Color		High Knocking Sound During Combustion	Abnormal Engine Sound	Uneven Combustion Sound	Engine Surging		Difficulty in Returning to Low Speed	Excessive Fuel Consumption	Engine Oil				Air Intake		Corrective Action	Reference Pages		
		Engine Does Not Start.	Engine Starts but Stops Soon.		Exhaust Color			During Work					During Idling	During Work Operation			Excessive Engine Vibration	Excessive Fuel Consumption	Dilution by Diesel Fuel	Oil with Water	Low Oil Pressure	Excessive Blow-by Gas			Pressure Drop	Pressure Rise
Cause		None	Little	Much	Ordinary	White	Black	White	Black																	
Fuel System	Air in Fuel System	○	○		○																		Bleed the Air.	See Priming the Fuel System on page 4-12.		
	Clogged or Cracked Fuel Line	○	○		○																			Clean or Replace.	See Check and Replace Fuel Hoses on page 5-36.	
	Insufficient Fuel Supply to Fuel Injection Pump	○	○		○																			Check the Fuel Tank Cock, Fuel Filter, Fuel Line, and Fuel Feed Pump.	See the appropriate procedure in Periodic Maintenance Schedule on page 5-15.	
	Uneven Injection Volume from Fuel Injection Pump					○	○	○	○		○	○	○	○									○	Check and Adjust.	See Adjusting Fuel Injector Pressure on page 7-25.	
	Excessive Fuel Injection Volume								○						○	○							○	○	Check and Adjust.	See Adjusting Fuel Injector Pressure on page 7-25.
	Poor Spray Pattern from Fuel Injection Nozzle					○	○	○	○		○	○	○	○	○										Check and Adjust.	See Adjusting Fuel Injector Pressure on page 7-25.
	Priming Failure	○																							Foreign Matter Trapped in the Valve Inside the Priming Pump (Disassemble and Clean).	See Fuel System Components on page 7-10.
Clogged Strainer at Feed Pump Inlet					○																			Clean the Strainer.	See Drain the Fuel Tank and Replace Outlet Fuel Filter on page 5-33.	
Air/Exhaust Gas System	Clogged Air Filter			○		○	○			○											○			Clean Air Filter.	See Clean Air Cleaner Element on page 5-29.	
	Engine Used at High Temperatures or at High Altitude					○	○							○								○			Study Output Drop and Load Matching.	-
	Clogged Exhaust Pipe					○	○			○												○			Clean Exhaust Pipe.	-
Electrical System	Starting Motor Defect	○																						Repair or Replace Stater Motor.	See Testing Electric Starter Motor Operation (Standard) on page 8-9.	
	Dynamo Defect	○																						Repair or Replace Dynamo.	See Testing of Charging System and Components on page 9-12.	
	Open-Circuit in Wiring	○																						Repair Open Circuit.	-	
	Battery Voltage Drop	○																						Inspect and Change the Battery.	See Check Battery (If Equipped) on page 5-17.	

This Page Intentionally Left Blank

YANMAR®

Head Office:

Yanmar Co., Ltd.

1-32 Chayamachi, Kita-ku, Osaka 530-8311, Japan
<http://www.yanmar.co.jp>

Yanmar America Corporation

951 Corporate Grove Drive
Buffalo Grove, IL 60089-4508, U.S.A.
TEL: 1-847-541-1900 FAX: 1-847-541-2161
<http://www.yanmar.com>

Yanmar Europe B.V.

Brugplein11, 1332 BS Almere -de Vaart,
The Netherlands.
TEL: 31-36-5493200 FAX: 31-36-5493209
<http://www.yanmar.nl>

Yanmar Asia (Singapore) Corporation Pte. Ltd.

4 Tuas Lane, Singapore 638613
TEL: 65-68615077 FAX: 65-68611509
<http://www.yanmar.co.jp/yasc/>

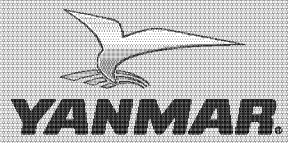

YANMAR CO., LTD.